

Battery Jars & Related Topics

Volume II



This volume presents the background & history of items that are used with and/or are related to Battery Jars: Including:

Medical Batteries, Trolleys, Battery Trays, Electric Vehicles, Battery Rests, Railroad Signaling, Battery Oil Bottles, Telephone, Telegraph, etc.

Battery Jars related to Volume II are found in Volume II and

Also, in Volume I

compiled by

Walter Baumgardt

Tonawanda, NY

2023

Battery Jars & Related Topics

Volume II

This volume presents the background & history of items that are used with and/or are related to Battery Jars: Including:

Medical Batteries, Trolleys, Battery Trays, Electric Vehicles, Battery 5 Rests, Railroad Signaling, Battery Oil Bottles, Telephone, Telegraph, etc.

**Battery Jars related to Volume II are found in Volume II and
Also, in Volume I**

Copyright ©2023 by Walter Baumgardt

All rights reserved. No part of this book may be reproduced, transmitted, stored or utilized in any form or by any means; electronic, mechanical, or by information storage or retrieval system without prior written approval from the author.

Compiled & Published by

Walter Baumgardt

Tonawanda, NY

2023

Dedication

The dedication of this book "**Battery Jars & Related Topics**" **Volume II** and its companion "**Battery Jar Catalog 2.1**" is two-fold.

First, is to my wife, Anne, who, although not a collector, has always supported my collecting and other endeavors in the hobby. Without her love and support this would not have been possible. I am forever grateful for her love and support.

Second, is to the hobby which means so much to me. The members have supported my endeavors by providing information, pictures, etc. on the topics covered. This book really belongs to the members of the NIA. That is why charging for this research was never an option. It is placed on the NIA website for all to use and enjoy.

Table OF CONTENTS

2.0	Acknowledgments	7
3.0	Preface	8
4.0	History of Battery Development	10
5.0	Electricity.....	14
5.1	Electrical Current	15
5.2	Alternating and Direct Current	19
5.3	War of the Currents	20
6	Battery Development	20
6.1	Battery Connections.....	25
6.2	The Storage Battery Simplified	27
6.3	Battery Jar Sizes	29
6.4	Definitions and Terms	30
7	Battery Oil Bottles.....	32
8.0	Battery Rests	47
9.0	Battery Trays.....	51
10.0	Electric Vehicles (EVs).....	58
11.0	Farm & Home Battery Systems62
12.0	Medical Batteries	68
12.1	Galvanic vs. Faradic Currents	75
12.2	Whitall Tatum & F.G. Otto & Sons,	78
12.3	Luis Drescher	81
12.4.0	Magneto Electric Machines	83
12.4.1	Davis & Kidder	85
12.4.2	James W. Queen & Co.	86
12.5	Voltamp	86
12.6	McIntosh Galvanic & Faradic Battery Co	92
12.7	Chloride of Silver Battery Co.	94
12.8	Otto Flemming	96
12.9	Edison Medical Batteries	98

12.10	Van Houten and Ten Broeck, Galvano Faradic Mfg. Co.	103
12.11	C.F. Birtman	108
12.12	Galvano Faradic Manufacturing Co.	109
12.13	Waite & Bartlett	111
12.14	Other Medical Batteries	114
12.15	Violet Ray	117
12.16	Pocket Batteries	123
	12.16.1 Smith & Shaw Electric Co.	123
	12.16.2 Dr. Drescher	125
12.15	Medical Batteries from Outside the U.S.	126
13.0	Railroad Signaling	130
13.1	Dr. William Robinson	135
13.2	Railroad Signal Jars & Lids	138
14.0	Telegraph and Telephone	143
14.1	Telegraph	143
14.2	J.H. Bunnell & Co. , Bunnell Telegraphic & Electrical Co.	150
14.3	Telephone	152
15.0	Street Cars / Trolleys	159
15.1	Granville T. Woods	167
16.0	Radios, Phonographs, Etc	168
	16.1.1 Fansteel Corp.	175
16.2	Phonograph Batteries, etc	181
17.0	Associated Equipment	186
17.1	Battery Water and Acid	192
18	Patents	196
19	Appendix A Battery Insulators, Oil Insulators and Chloride Accumulators by Charles & Sandi Iron .	199
20	Appendix B Batteries & Extras Charles & Sandi Irons	203
21	Appendix C Gamewell Battery Support Insulator	209
22	Appendix D Electric Vehicles circa 1905	216
23	Appendix E ESB Catalog of 1906	226
24	Appendix F Street Car Power Plants Circa 1902	256
25	Appendix G Edison LaLande Batteries Catalog Late 19 TH Century	269

26	Appendix H: The Smith & Shaw Closed Cell Medical Battery	287
27	Appendix I: MARVEI Violet Ray	289
28	Appendix J Railroad Growth in the U.S. by Decade	325
29	Appendix K J. Birtman Patent	329
30	Appendix L Wexler Paper	339
31	Vintage Advertisements	365
32	Bibliography	371
33	Index	375

2 ACKNOWLEDGEMENTS

Before I begin, I want to thank those whose contributions enhanced this study of battery jars. Tommy Bolack graciously opened his Museum and home to me. Tom and Lynda Kotanak and my wife and I spent 3 days cataloging Tommy's collection of battery jars. The sheer volume of his collection, alone, resulted in this study being split into two volumes.

Debbie Graham graciously provided information on her large collection of battery jars, including pictures, etc.

Rick Taylor shared his extensive collection of battery oil bottles. An entire chapter is dedicated to them.

Bob Berry shared his time and advice on computer matters.

Wayne Duzyinski shared his collection of battery jars.

I want to thank the EBAY community of sellers. Many of the jars in the Catalog came from EBAY listings, and all with permission of the sellers. I appreciate their generosity in sharing. It has added immensely to this study.

There are many others whom I have not forgotten. In fact, the entire membership of the NIA has been supportive of my efforts. I just wanted to give a special mention to those who went above and beyond. I have tried to credit everyone who contributed when discussing a particular entry.

Thank you all for your contributions.

3 PREFACE

This project started as an attempt to document known battery jars, trays, and other battery associated equipment that may exist. The scope of the project soon dictated that it be split into two volumes.

This is **Volume II** of the Battery Jar Catalog. It contains the discussion and background on the topics listed below. You will note that they all used battery jars, but are primarily battery jar related, rather than Battery Jar centered. Thus, the decision to separate them into a separate volume, in order to keep both volumes a manageable size.

Volume II contains the discussions on related items, such as:

- Electric Vehicles
- Street Cars (Trolleys)
- Railroad Signaling
- Medical Batteries
- Pocket Batteries
- Farm Battery Systems
- Associated Items
- Battery (Sand) Trays
- Battery Rests
- Battery Oil Bottles
- Patents
- Telegraph, Telephone,
- Radios, Phonographs, Etc.
- Vintage Advertisements

Volume I presents the battery jars themselves with a brief history of either the manufacturer of the jar or of the major embossing on the jar itself. Unembossed battery jars and embossed jars on which no history could be found are in the Unknown Chapter. **Both Volumes** contain a History of Battery Development and a primer on electricity. This is an overview only and not intended to be an in-depth study of battery jars and electricity. If you are interested in further information and/or study, the Bibliography lists all my sources. The Bibliography covers both Volumes, while the Index is unique to the Volume it is in.

With the exception of, Medical Batteries, all individual battery jars are found in **Volume I**. The actual battery jars used in Medical Batteries and Radio/Phonograph are found in both volumes to minimize switching between volumes. The section on Vintage Advertisements is also unique to topics discussed in Volume II. Volume I will have a Vintage Advertisements Chapter that is Battery Jar and/or Battery centered.

If you are only interested in the battery jars themselves, **Volume I** will be of the most interest to you. If you are interested in the discussion on the related items, Volume **II** will likely interest you.

Between the two volumes, you should get a pretty good understanding of battery jars, related topics and the role they played in the electrification of America.

The layouts of the two volumes are slightly different. Volume II Chapter headings are by major topic, such as medical batteries, railroad signaling, etc. These major topic areas lend themselves

to sub-headings, which are designated with a (.). For example, Chapter 11 on Medical batteries is broken down into 11.1, 11.2, 11.3. etc. . Pictures are numbered with another (.) designation, such that Chapter 11 flows as follows:

Major Heading: Chapter 11 [pictures are designated as 11.1, 11.2, 11.3,].

Subheading: Chapter 11.1 [pictures are designated as 11.1.1, 11.1.2, 11.2.3,].

Subheading: Chapter 11.2 [pictures are designated as 11.2.1, 11.2.2, 11.2.3,].

With the exception of the Chapters on Battery History and Development, which are laid out as indicated above, Volume 1 Chapter Headings are by Either Manufacturer Name or by Major Embossing on the battery jar. As a result, there are few Subheadings in Volume I. Pictures in Volume I are designated as above, with a (.) designation.

Happy Reading. I learned so much in researching and putting this project together, that I feel selfish in a way. My wish is that you learn half as much as I did about this important era in our history.

Walt Baumgardt

4 HISTORY OF BATTERY DEVELOPMENT

There are still only two ways to generate electricity, electromechanically and chemical reaction. Although Michael Faraday discovered the electromechanical generation in the early 1800s, it

was the end of the century before it became practical. The first large scale use of electricity was the Buffalo World's Fair of 1901. It was powered by electricity generated 25 miles north at the Niagara Power Station. This event dubbed Buffalo with the title "City Of Light".

Distribution was a problem. The cost of transporting electricity proved prohibitive. The result was that a great deal of the United States relied on electricity generated by a chemical reaction from the last half of the 18TH century to the mid 20TH century. Let's look at some statistics. The term electrification refers to electricity generated electromechanically rather than by chemical reaction.

- By 1920 about 90% of urban communities were on commercial power grids.
- At the same time only 3% of The United States was considered urban.
- In 1920 only 5 % of rural America was electrified.
- At the start of WWII (circa 1940) only about 30% of rural America was electrified.
- In 1956, about 95% of rural America was electrified.

Until electrical distribution was available to everyone, much of America relied upon Farm / Home batteries for their electrical needs.

The role of the REA (Rural Electrification Act) enacted in 1936 was to promote the electrification of America. With local and regional promotions such as "REDDY KILLOWATT" it seems to have been successful. The fact remains, however, that for almost a century our electrical power was generated on jars via a chemical reaction.

We will start by looking at the individuals who played a role in the development and understanding of electricity. Strangely, the first battery of modern times was invented by **Benjamin Franklin** an American Statesman in the 1700s. Development then switched to Europe until we get to **Thomas A. Edison** in the late 1800s.



The invention of the Leyden Jar in 1745 in a joint discovery by cleric **Georg von Kleist** and Dutch scientist **Pieter van Musschenbroek** of Leiden (Leyden) paved the way for the discoveries that came later. The Leyden Jar is an electrical component which stores a high-voltage electrical charge (from an external source) between electrical conductors on the inside and outside of a glass jar.

←**4.1**

Using a Leyden jar (**4.1**), Benjamin Franklin was able to determine that "positive " charges resided on one side and "negative "charges on the other side of the jar. Franklin also discovered that by linking several jars together, he could increase the amount of charge they could store. He called this combination of Leyden Jars a "Battery" and is credited with being the first to use the term "Battery" in relation to electricity. It was commonly believed, at the time, that there was a relationship between lightning and electricity. Franklin set out to prove it. He listed 12 things in common between lightning and electrical fire.

- | | |
|----------------------------------|--------------------------------------|
| 1. Giving light | 3. Swift motion |
| 2. Crooked direction | 4. Crack or noise in exploding |
| 5. Being conducted by metals | 6. Color of the Light |
| 7. Destroying animals. | 10. Sulfurous smell |
| 8. Melting Metals | 11. Rending bodies it passes through |
| 9. Firing inflammable substances | |
| 12. Subsisting in water or ice | |

This led to Franklin's famous experiments with lightning, proving that clouds were electrically charged.

A friend of Franklin, Peter Collinson, wrote of Franklin's experiments in detail and sent them to French Naturalist Georges-Louis LeClerc, who had them translated into French.

In 1800 **Allesandro Volta** created the first electric cell. He soaked paper in water, placed zinc and copper on opposite sides of the paper and watched a chemical reaction create an electric current. By connecting several cells together, he created a battery. The world had a safe and dependable source of electricity, making it easy for scientists to study this new power source. It is in honor of Volta that we rate batteries in volts.

In the early 1800s, **Michael Faraday**, an English scientist, was the first to realize that an electric current could be produced by passing a magnet through a copper wire. Almost all the electricity we use today is made with magnets and coils of copper wire.

In 1827 **George Ohm**, a German physicist, introduces the concept of electrical resistance.

In 1844, **Samuel Morse** develops telegraphy and the Morse Code.

In 1859, **Gaston Plante**, a French Physicist invented the first rechargeable battery; the lead-acid battery. In 1880, **Camille Faure** improved upon the design, patenting a method of coating [lead](#) plates with a paste of lead oxides, [sulfuric acid](#) and [water](#), which was then cured by gentle warming in a humid atmosphere. The curing process caused the paste to change to a mixture of [lead sulphates](#) which adhered to the lead plate. During charging the cured paste was converted into electrochemically active material (the "active mass") and gave a substantial increase in capacity compared with Planté's battery.^[6] This was a significant breakthrough that led to the industrial manufacture of lead-acid batteries, as now used for starting motor cars.

In 1886, **Henri Tudor**, a Luxembourg inventor, improved upon the Electrodes, by applying a weak intensity current until the paste is transformed into lead peroxide on the cathode and into reduced lead on the anode. This improvement led to a weight reduction in the electrodes while increasing their capacity, leading to a 15% reduction in price.

The turning point of the electric age came towards the end of the 19TH century with the discovery of Alternating Current (AC). Croatian born scientist, **Nikola Tesla**, came to the United States to work with **Thomas Edison**. After a falling out, **Tesla** discovered the rotating magnetic field and created the alternating current (AC) electrical system. He partnered with **George Westinghouse**

to patent the AC system. Alternating Current was able to deliver electrical power over long distances, whereas Edison's Direct Current (DC) could only deliver it within a mile radius.

Thomas A. Edison was the most productive electrical scientist in the latter part of the 18TH and early 19TH centuries. He developed the first long lasting light bulb, the phonograph, motion pictures and many other products that electricians use or install. He is the owner of over 3000 patents in the field.

Alexander Graham Bell, a Scottish inventor, patented the telephone in 1876.

George Westinghouse was a champion of Alternating Current vs. Edison's Direct Current See chapter 2 for a brief history of the "Current Wars" between Westinghouse and Edison. In 1893 Westinghouse used an AC system to light the Chicago World's Fair.

In 1881 The Brush Electric Co. of Buffalo installed the first electric plant which supplied power for a mile of carbon arc lights. At this time, the Niagara Falls power plants were being built, and in 1896 a 22-mile-long AC powerline was opened to transmit electrical power from Niagara Falls to Buffalo, NY. This same power lit The Pan American Exposition in 1901. This resulted in Buffalo being nicknamed the "City of Light."

As you go through these pages, you will find that Alternating Current, like we use today was generated in the mid 19TH century, during the Civil War. However, it took until the end of the 19TH century for Nikolai Tesla to develop the system to a usable state. We don't know if the mid-century inventors didn't know what they had or if the rest of the technology wasn't at a state to develop it further. As a result, particularly in rural areas, our electricity came from a jar as the result of a chemical reaction until the mid 20TH Century.

Remember, the entire modern world was undergoing this awakening of electrical power; thus, we find scientists of many nations involved in the development. This is evidenced by the nationalities of the few scientists named above. There were many others, but these few suffice to show the international effort in the discovery and production of electricity.

You will observe that the above list is largely European. America was still a young nation, struggling for an identity in the world. It wasn't until after the Civil War that we became established and accepted. Thomas Edison was one the first of many Americans to revolutionize the world with their inventions.

Edison's discoveries are all the more remarkable when you consider that he had only a few months of advanced education. T.A. Edison was born in 1847 in Milan, MI and grew up in Port Huron, MI. He attended formal school for only a few months. His mother, a teacher by profession, taught him reading, writing and arithmetic. A chemistry class at the Cooper Union for the advancement of science and art is his only known enrollment of any kind at an institution of higher learning. He was a curious child and learned most things by reading on his own. An early bout with Scarlet Fever caused the loss of hearing in one ear and most of the hearing in the other. Edison believed that his hearing loss allowed him to avoid distraction and to concentrate more easily.

Rutgers U. seems to maintain the records and information about Thomas A. Edison. If anyone is interested in learning more about his career, I refer you to:

<https://edison.rutgers.edu/company.htm>.

Throughout his career he received 1,093 U.S. patents in his name and counting his foreign patents the total is about 3000. He formed about 200 companies. If we attempt to break them down by category, we find:

Battery:	7	Office Machinery & Supplies:	6
Cement & Cement Products:	7	Phonograph, Domestic:	14
Electric Light, Domestic:	15	Phonograph, Foreign:	16
Electric Light, Foreign:	24	Railway:	6
Mining:	11	Telegraph & Telephone, Domestic:	28
Miscellaneous:	11	Telegraph & Telephone, Foreign:	14
Motion picture:	13		

Some information about the various battery companies:

Thomas A. Edison, Inc., originally the National Phonograph Co., was the main holding company for the various manufacturing companies established by Edison. It was the successor to the Edison Mfg. Co. and operated between 1911 and 1957 when it merged with McGraw Electric to form McGraw Edison.

The **Edison Mfg., Co.** was incorporated in 1900, as Edison's personal business. It manufactured and marketed the Edison-LaLande primary battery, as well as batteries for telegraph, telephone, phonograph. It also sold X-Ray equipment, medical instruments and electric fans as well as having a motion picture branch. The LaLande (Edison Storage Battery Co.) was an alkaline primary battery developed by Edison from an earlier design by Felix LaLande. It consisted of copper oxide and zinc plates in a solution of potassium hydroxide.

The **Battery Supplies Co.**(BSCO) was formed in 1903 by former Edison Employees to manufacture primary batteries. Edison sued, alleging patent infringement. A settlement called for the Edison Mfg. Co. to purchase it in 1905. It was officially dissolved in 1908.

The **Edison Storage Battery Co.** Although the initials are the same, The **Edison Storage Battery Co.** is not to be confused with the **Electric Storage Battery Co. (ESB Co.)**. In my research, I have never seen the **Edison Storage Battery Co.** referred to as (E.S.B. Co.), while references to The Electric Storage Battery Co. was commonly referred to as the E.S.B. Co. I will continue that distinction, referring to the Edison Storage Battery Co. with its full name, while referring to the Electric Storage Battery Co. as E.S.B. Co.

The **Edison Storage Battery Co.** was formed in 1904 to produce Edison's nickel-iron battery. Edison's life-long dream was the electric vehicle, and the Battery Supplies Co. was to make it happen. He refined the nickel-iron battery first patented by Swedish inventor, Ernst Waldemar Jungner in 1899. It was so revolutionary that even Henry Ford wanted it. He struck a deal with Edison in 1914, to release the "Ford Electric", selling for \$900.00 with a range of 100 miles. However, the Edison Battery was big, heavy, expensive and required frequent charging. By the

time Edison's project was complete, consumers had spoken in favor of the fossil fuel-powered Model T. The nickel-iron battery never became very successful. In 1960 the Edison Storage Battery Co. became part of Exide Technologies, formerly The Electric Storage Battery Co.

As a side note, Edison championed Direct Current for many years, claiming its superiority over alternating current. Westinghouse and The Thomas Huston Co. championed the alternating current. Edison used what some might consider un-ethical means to combat AC current, which didn't sit well with his Board of Directors. *See the War of the Currents for more information.* In 1892 J.P. Morgan engineered a merger between Edison-General Electric and Thomas Huston that put the Board of Thomas Huston in charge of the new company; General Electric. Edison was essentially forced out of controlling his own company. General Electric now controlled 75% of the U.S. Electrical business and would compete with Westinghouse for the AC market.

Ironically, today's electronic devices require Direct Current meaning Alternating Current has to be converted back to Direct Current in order to power any electronic devices. This is accomplished with commutators or rectifiers. Dry cell batteries supply DC so no further modification is needed.

5 Electricity

By 1840 – 1850, the concept of producing an electrical current with dissimilar metals in an acidic solution was solidly established. It led to the development of the telegraph, telephone and other equipment which needed a power source. It played a major role in communication during the Civil War and the later westward expansion.

Electricity is the flow of electrons from one point to another. All matter is composed of atoms, which contain a positively charged nucleus (a mixture of protons and neutrons). The nucleus is surrounded by negatively charged particles known as electrons.

5.1 Electrical Current

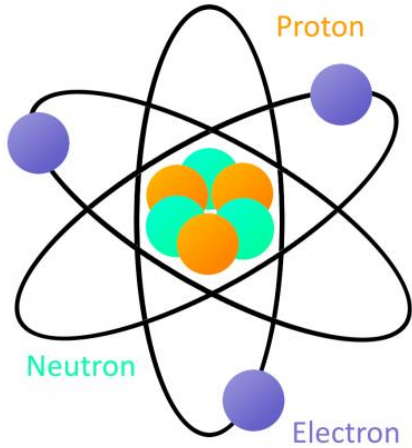

←**5.1.1** shows this arrangement of Protons, Neutrons and Electrons. The number of protons equals the number of electrons.

The electrons in the outer orbits, furthest from the nucleus, are called valence electrons and with enough outside force can escape the orbit and become free. These free electrons allow us to move a charge.

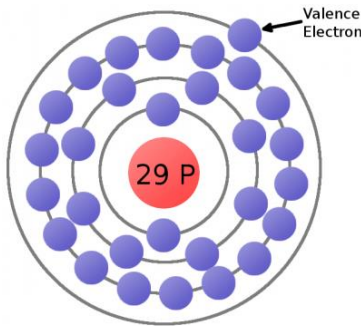

←**5.1.2** shows a copper atom. It is the lone electron in the outer orbit that can become free and create a charge.

We know that opposites attract and likes repel one another, as shown in **5.1.3**.

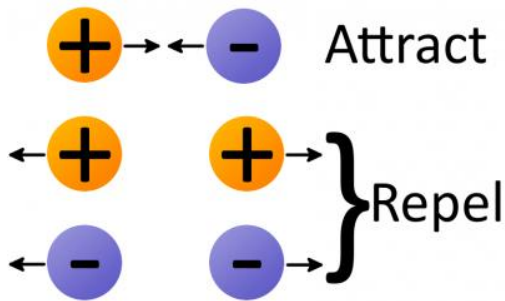

← **5.1.3**

Thus, electrons and protons attract one another.

5.1.4 depicts the flow of this charge in a copper wire filled with countless copper atoms. The free electron is floating in space between atoms is pulled and prodded by surrounding charges. Eventually the free electron finds a new atom to latch on to. In doing so, it ejects another valence electron from the new atom. This chain effect can continue and in so doing creates a flow of electrons called electric current.

5.1.4↓

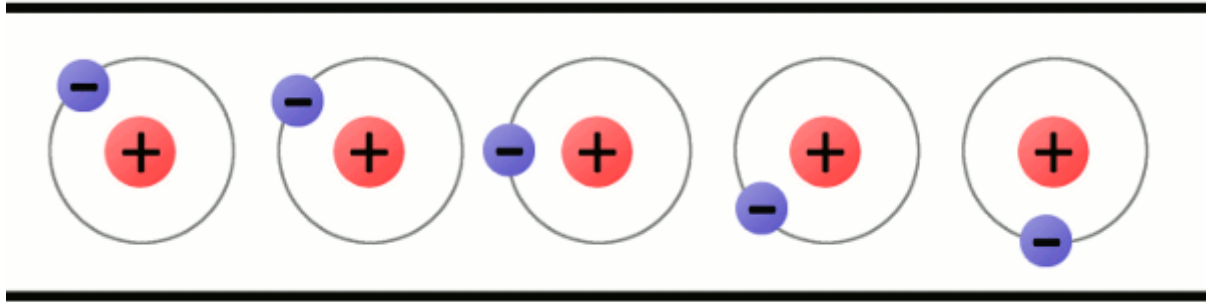

Batteries are sources of energy which convert chemical energy to electrical energy. The two battery terminals connect to the rest of the circuit. On one terminal is an excess of negative charges, while all the positive charges group at the other terminal. This is depicted in **5.1.5**↓.

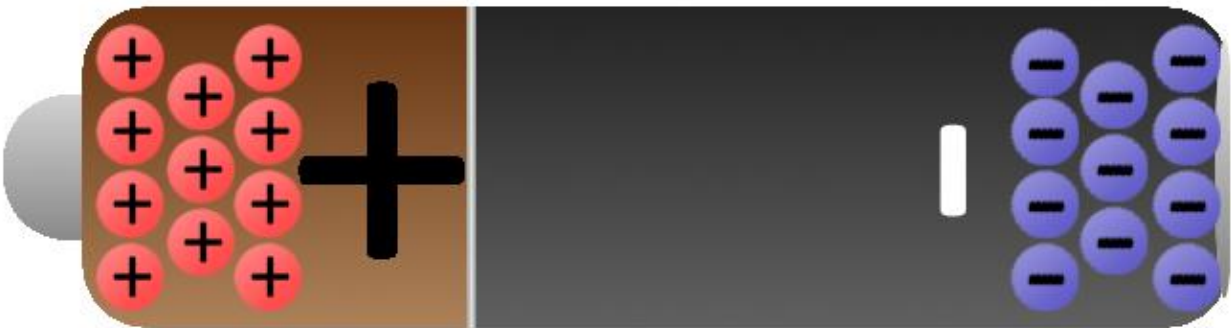

If we connected our copper wire to a battery, we would create a flow of electrons, electricity, from one terminal to the other as shown in **5.1.6**. Rather than wasting this energy, if we build a circuit with a switch and an appliance that needs power, such as a light, we are making use of the electrical potential that has built up in the battery (**5.1.7**).

It is important to understand that the flow of electrons does not happen as if by magic. The electrode materials and the electrolyte have to be chosen because it is the chemical reaction that occur between these three components that excites the electrons creating the electrical charge we can then use as power. We will explore this in layman's terms in chapter 6.3.

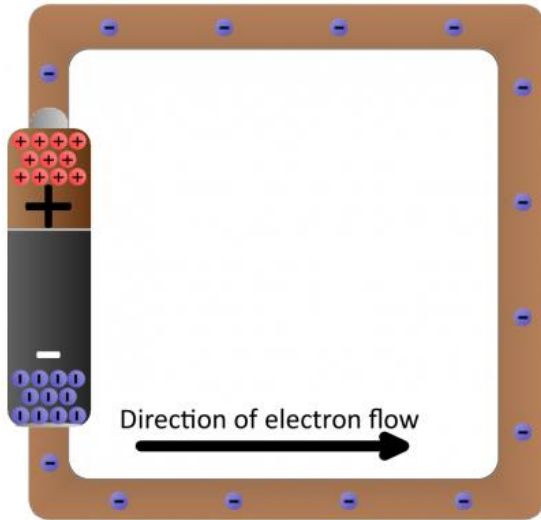

5.1.6↑

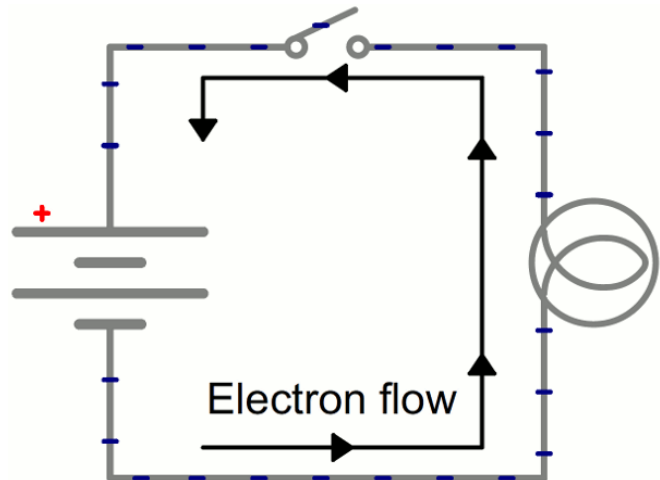

5.1.7↑

Electrical current is the potential energy stored in the battery. In the natural order of things, the flow is from a state of high potential to a state of low potential energy, as seen in 5.1.8. Lightning is an example of this release of high potential energy to a more stable state of lower potential energy.

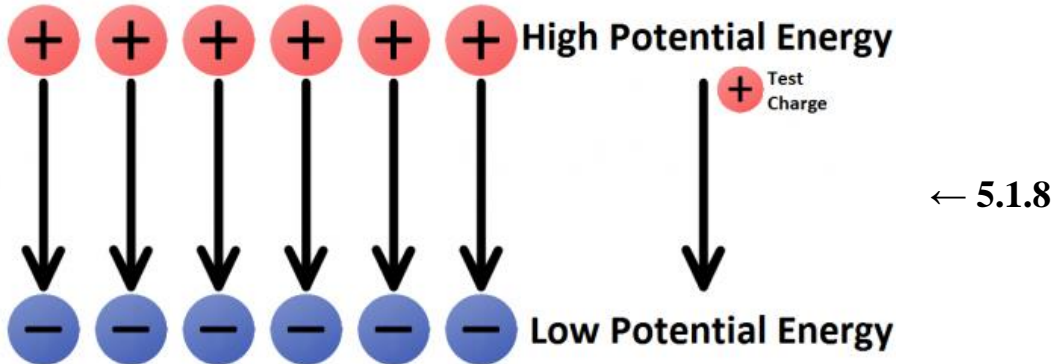

A Battery Jar is simply a container, round, square, or rectangular, containing this high potential energy. Usually they are glass, but they also were made in porcelain and modified hard rubber, whose sole purpose is to hold the components of a battery. The earliest jars were generally hand blown, with a ground lip**, open at the top and fitted with lead electrodes (anode and cathode) in an electrolyte solution of sulfuric acid and water, (based on the Plante battery patented in 1859). The reaction of the acid with the dissimilar metal electrodes produced an electric current. The Cathode is the Positive (+) electrode, and the Anode is the Negative (-) electrode. The chemical reaction of the electrode with the electrodes causes an electric current to flow between the Cathode and Anode. There are many who believe that the battery was a great idea, and that the early batteries were a great idea in search of a purpose. To a large extent, this was true.

The open tops resulted in acid leakage, which resulted in corrosion to surrounding areas. Battery trays, commonly known as sand trays, were used to collect the acid leakage and prevent the damage. Battery trays were shallow flat trays of glass which were filled with sand. The batteries were placed in the sand trays which collected the acid dripping from the batteries. The earliest battery trays were made of wood and lined with lead. Due to the nature of their construction, these trays did not survive, and none are known. Some of the glass trays did survive. What I have found are identified in Chapter 8.

It was also found to be necessary to insulate the batteries from their surroundings, to prevent short-circuiting the battery. The acidic nature of the early batteries would soon create a fine acidic coating on everything, causing the battery to short. Battery rests helped to solve this problem. The picture below, (5.1.9), shows such battery rests in use. Note the battery rests under each of the batteries, as well as the larger rests under the battery supports. The topic of battery rests is discussed fully in “Battery Insulators, Oil Insulators, and Chloride Accumulators”, by Charles and Sandi Irons (2005). This is reproduced (with permission) in Appendix 67. In addition, the “Guide for North American Pin Type Insulators” has a well defined and dedicated section on battery rests. The Price Guide is available from Andrew Gibson of Dansville, NY. Mr. Gibson can be reached at www.insulatorpriceguide.com.

↓ 5.1.9

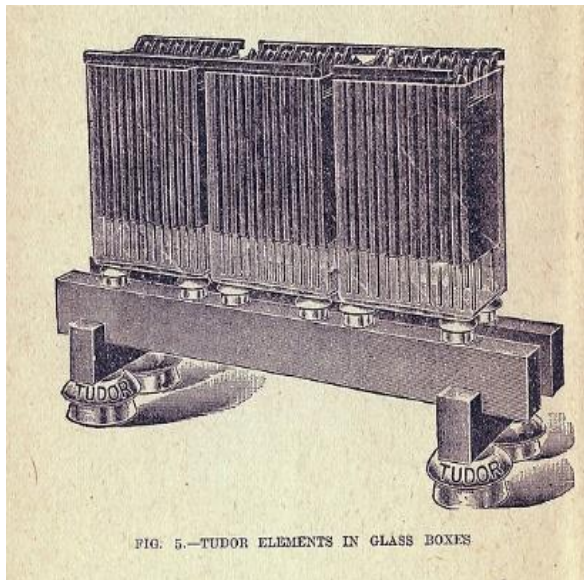

**A ground lip is a method of finishing the jar, rather than being a finish. This form of finishing a jar originated with fruit jars and carried over to other, open topped vessels. The early fruit jars were hand blown, with uneven tops. In order to form a seal with the jar lids, the tops needed to be smooth and perpendicular to the threads in order to achieve a proper seal with the lid. This was achieved by grinding the hand-blown surface with a wheel achieving a relatively smooth surface, looking like a sanded surface. This process of finishing the lip was carried over to

battery jars. As automatic machines were introduced it became possible to achieve the needed lip surface as the jar was being made, without the added step to finish the lip. According to the literature (Talouse, etc.) this transition occurred over a period of years, from approximately 1880 to 1900.

5.2 DIRECT VS. ALTERNATING CURRENT

Electricity was only useful if it could be transported over long distances. With this in mind consider that there are two types of electrical current, Direct Current (DC) and Alternating Current (AC). Battery jars produce only Direct Current. An alternator is required to convert DC to AC.

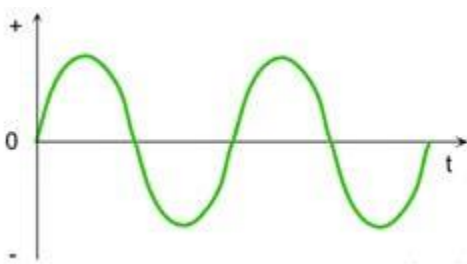

5.2.1



5.2.2

5.2.1 and **5.2.2** picture Alternating and Direct current. Alternating current changes direction (both positive and negative). The waveform of pure AC is a sine wave. Direct current always flows in the same direction. It's either positive or negative. Pure DC is a flat line.

There are pros and cons of each.

Direct Current:

- DC electricity is easier to store.
- DC motors are more efficient than AC by 15% -20%.
- The major problem with DC is that it cannot be transmitted over long distances.

Alternating Current:

- The main advantage of AC is its ability to be transmitted over long distances with minimal energy loss. This makes it ideal for electrifying towns, cities, and even the whole country.
- Most equipment runs on Direct current. The conversion from AC back to DC results in approximately a 20% loss in power. Although most electronic equipment still require DC, most household appliances have been reconfigured to run on AC

- Although both AC and DC are dangerous, AC is most likely to cause heart fibrillation and death.

The differences in current led to what is known as the *War of the Currents*.

5.3 WAR OF THE CURRENTS

The history would not be complete without mentioning the “**War of the Currents**”. Each current, either Direct or Alternating had its champions. George Westinghouse championed Alternating Current while Thomas Edison championed Direct Current. This was the battle that took place between these two men to determine which electrical system would be the one to electrify America. Both men knew that there was only room for one system, and Edison set out to ruin Westinghouse in a ‘great political, legal and marketing game’.

Edison realized the Alternating Current was the better system, because of the transmission issue, but refused to relent. He hired Nikola Tesla to solve the problem and/or design a new system. When Tesla told Edison that the future of electrical transmission was Alternating current, Edison reportedly fired him, and, according to Tesla, refused to pay him for the work he had done.

To sway public opinion about the dangers of alternating current, Edison reportedly electrocuted dogs, cats, calves, horses and even an elephant to show that alternating current was dangerous. In his defense, all the animals were destined for euthanasia to start with. It was the manner in which Edison went about it that enraged people.

Westinghouse, in the meantime had purchased all rights to Tesla’s patents. The beginning of the end of direct current was in 1896 when Westinghouse and Tesla harnessed the power of Niagara Falls and sent electricity all the way to Buffalo, NY.

Edison attempted to borrow money from J.C. Morgan to buy The Thomson-Houston Electric Co., which in a period of only ten years had grown to the third largest energy producer. Westinghouse and Edison were the other major suppliers. Instead, Morgan, himself, purchased Edison and Thomson-Houston to create The General Electric Co. The Board of Directors, enraged with Edison’s shenanigans to promote direct current, left him as a member of the Board of Directors, but, with no authority or power in the company. The final straw was when Westinghouse was awarded the contract to provide electricity for the 1900 World’s Fair in Buffalo. In the end, alternating current won because it was simply the best system. Westinghouse and Thomson Houston went on to power America. References: 61,62

6 BATTERY DEVELOPMENT

The earliest batteries were called Primary Batteries, because they were not rechargeable. When the electrodes were spent you dumped the whole thing out and started over. The advent of the Secondary Batteries, which were rechargeable, enabled batteries to have sealed lids. A perfect example was Farm batteries, which were sealed and used an internal combustion engine for recharging. The jar lids were either glass, porcelain, or hard rubber. By the latter part of the 1800s and early 1900s, batteries were developed with different electrodes that used an electrolyte other than acid, thus eliminating the dangers of acid usage. The Leclanche battery, patented in 1866, was one of these alternative batteries. It used Zinc and Carbon Manganese electrodes with Ammonium Chloride as the electrolyte. The Plante, Lead – Acid battery, the first rechargeable battery, remained popular as automotive, and farm and home batteries, but the less hazardous, and lighter, LeClanche battery was far friendlier for telegraph and telephone use.

Comparing the differences of Lead-Acid vs. LeClanche batteries, helps to explain how their usage dictated which was used.

In a LeClanche battery the voltage falls steadily with discharge, whereas in a Lead-Acid Battery the voltage is constant.

- The Energy density of a LeClanche Battery is very low, whereas the Lead-Acid battery can deliver very high currents.
- The LeClanche battery does not perform efficiently at high current drain applications.
- The shelf life of The LeClanche Battery is not very good.

Looking at these differences you can see why the lead-acid battery was the choice for high demand systems such as automotive and the farm and home battery systems. The decreased power demand of telegraph and telephone service favored the LeClanche battery.

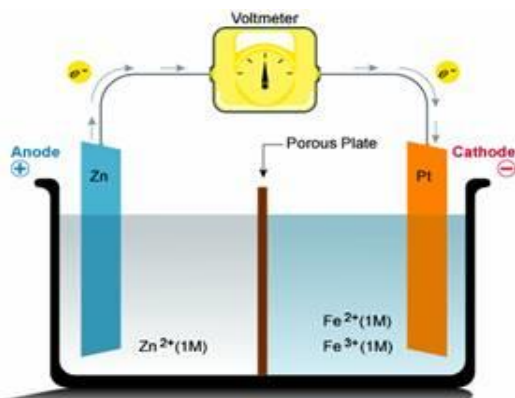

← **6.1** is a schematic of a battery jar with a single set of electrodes, depicting the Plante battery invented in 1859. It is still widely used in automobiles today. It is a single cell and also the simplest battery. It gets confusing because the term cell and battery are used interchangeably. Convention, however, dictates that a battery is a minimum of 2 cells. Single cells, or batteries, can be linked together to increase the voltage. This can be done by linking individual jars together or by increasing the size of the jar and adding

additional sets of electrodes to the same jar. A spacer is needed between the electrodes, to prevent them from touching, a single cell will always have an odd number of plates. 3 plates being a single cell or the simplest battery.

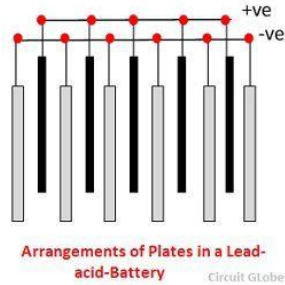

←**6.2:** The plate arrangement in a lead – acid battery , showing the alternating positive and negative plates. (Note: in this simplified format the spacers are not shown).

Electrodes varied in size and shape.
6.3, right, is the typical plate assembly.

6.3→



6.4↓



6.5↓



6.6↓



6.7↓

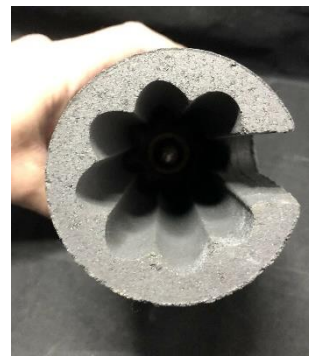

You will find, however, that most circular jars used circular electrodes, as seen in **6.4** through **6.7**. The anode and cathode were still present, but arranged differently, one around the other. The basis of the Fitch Perfect Battery, it came in different shapes.

Other electrode variants are seen in **6.8** through **6.10**. Sizes and shape may vary, but the concept remains the same.

6.8↓

6.9↓

6.10↓



6.1.9 and **6.1.10**, are from the McIntosh Medical Battery.

The following table (**6.11**) lists a portion of the chronology of the development of the battery, concentrating on the wet cells which used battery jars. It should be noted that the Plante Lead Acid battery of 1859 was the first Secondary battery. Everything prior to this was a Primary battery and could not be recharged.

It stands to reason that the early work was done in Europe. At the time wet cell batteries were being developed, the United States was a new nation, still struggling for survival. It wasn't until after the Civil War, in the latter half of the 19th Century that the United States had an identity in the world. The work of Thomas Edison helped to establish the United States as an innovative force in world, and we start to see technological advances originating here rather than abroad.

6.11 Chart of Wet Cell Battery Variations

<u>≈Year</u>	<u>Name of Cell</u>	<u>Country</u>	<u>Anode</u>	<u>Cathode</u>	<u>Electrolyte</u>	<u>Volts</u>
--------------	---------------------	----------------	--------------	----------------	--------------------	--------------

250 BC	Baghdad Battery		Iron	Copper	Unknown	
1799	Volta (Wollaston, etc.)	Italy	Zinc	Copper	Solution of Sulfuric Acid	1 to 1.5
1836	Daniel	England	Zinc	Copper	Zinc Sulphate	1.1
1838	Poggendorf (Dancer)	Germany			Version of Daniel Cell	
1839	Bird	England			Version of Daniel Cell	
1839	Grove	England	Zinc	Platinum	Dilute Sulfuric Acid	2
1840	Smee	England	Zinc	Platinized Silver	Solution of Sulfuric Acid	1 to 1.5
1842	Grenet	France	Zinc	Graphite (Carbon)	Solution of Sulfuric Acid	2.1
1842	Bunsen	Germany	Zinc	Graphite (Carbon)	Dilute Sulfuric Acid	1.8
1842	Bunsen variation of previous)	Germany	Zinc	Graphite (Carbon)	Dilute Sulfuric Acid	1.8
1850	Poggendorf (Grenet)	German	Zinc	Graphite (Carbon)	Solution of Potassium Dichromate and Sulfuric Acid	2
1850	LaLande	France	Zinc	Copper Oxide	Caustic Potash or Potassium Hydrate	0.9
1859	Plante (Lead Acid)	France	Lead	Lead Dioxide	Concentrated Sulfuric Acid	1.8 - 2.1
1860	Fuller	England	Zinc	Carbon	Sulfuric Acid	
1863	Callaud	France	Copper	Zinc	Zinc Sulphate	
1866	LeClanche	France	Zinc	Manganese Dioxide	Ammonium Chloride	1.4
1886	Carl Gassner	German			The dry cell, based on the LeClanche cell of 1866	
1893	Weston	English American	Cadmium	Mercury	Cadmium Sulphate	1
1899	Jungner	Sweden	Nickel	Cadmium	Potassium Hydroxide	
1900	Edison	American	Iron	Nickel Oxide	Potassium Hydroxide	1.4

6.1 BATTERY CONNECTIONS

Batteries can be connected together in two ways. One will increase the Voltage of the system, while maintaining the Capacity. The other maintains the Voltage but increases the Capacity. The capacity of a battery is rated in amp-hours. It tells you the amperage that a battery can provide for one hour.

Series connections involve connecting 2 or more batteries together to increase the voltage of the battery system but keeps the same amp-hour rating. Keep in mind, in series connections each battery needs to have the same voltage and capacity rating, or you can end up damaging the battery. To connect batteries in series, you connect the positive terminal of one battery to the negative of another until the desired voltage is achieved.

In the image below (6.1.1) there are two 12V batterie systems, connected in series which turns this battery bank into a 24V system. You can also see that the bank still has a total capacity rating of 100 Ah. Connecting the cells in series increases the voltage while maintaining the capacity.

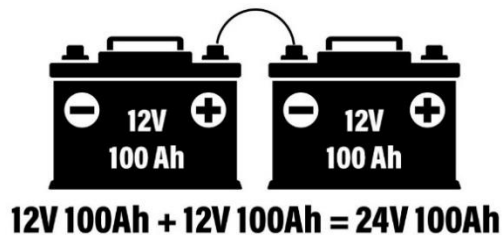

6.1.1↑

Parallel connections involve connecting 2 or more batteries together to increase the amp-hour of the battery bank, but your voltage stays the same. To connect batteries in parallel, the positive terminals are connected, via a cable, and the negative terminals are connected with another cable, until you reach your desired capacity, as in the diagram below (6.1.2).

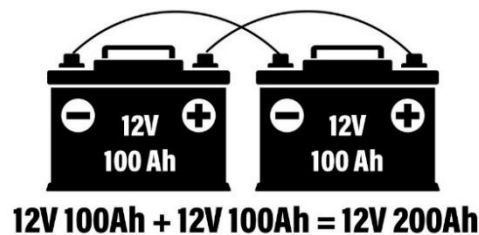

6.1.2↑

A parallel connection is not meant to allow your batteries to power anything above its standard voltage output, but rather increase the duration for which it could power equipment. As you can see, the system remains at 12 volts, but the capacity has increased to 200Ah. Connecting the cells in Parallel increases the capacity of a battery, while maintaining the Voltage.

Table **6.1.3** (below) shows the relationship between amp hours and the rate at which you use them. To increase the capacity of a battery, connect your cells in Parallel. To increase the Voltage, connect your cells in Series.

Table 6.1.3				
Battery Capacity	Discharge Rate			
	1 Amp Draw	2 Amp Draw	3 Amp Draw	4 Amp Draw
2 Amp hour	2 hours	1 hour	40 minutes	30 minutes
3 Amp hour	3 hours	1 hour 30 minutes	1 hour	45 minutes
4 Amp hour	4 hours	2 hours	1 hour 20 minutes	1 hour
5 Amp hour	5 hours	2 hours 30 minutes	1 hour 40 minutes	1 hour 15 minutes
6 Amp hour	6 hours	3 hours	2 hours	1 HOUR 30 MINUTES

6.2 THE STORAGE BATTERY SIMPLIFIED

I came across a reference that simplifies the explanation of a Secondary or Storage battery. It is www.PowerStream.com/1922/battery. It was written by A.O Witte in 1922 and explains the working of a battery in non-technical terms.

There are only two ways of generating electricity; magnetically or chemically. The magnetic method was discovered by Volta, and led to the development of Alternating Current. It is basically a generator in which wires are rotated in a magnetic field.

We are interested in the second or chemical method. If two unlike metals (electrodes) are placed in a liquid (electrolyte) which causes a greater chemical change on one electrode than the other, an electrical pressure is built up. The greater the difference in the chemical change, the greater the electrical pressure. If the electrodes are connected together outside of the electrolyte an electric current will flow through the path (circuit) consisting of the electrolyte, electrodes and the external wire.

As the current flows through the circuit the electrodes continue to change chemically, until one of them is entirely changed, at which point current flow stops and the battery is dead. This basically describes a Primary battery.

The chemical change usually results in the formation of gases or solid chemical compounds. If gases are formed those materials are lost forever. If solids are formed, no material is actually lost. If the proper electrodes and electrolyte were used, it may be possible to recharge the battery. This is done by sending an electric current through the cell in reverse, producing the same chemical reactions in reverse. When fully charged we have the original cell as if it had never been used. The battery is now ready to be used again. This describes the Farm Battery system where a gasoline powered engine was used to recharge the batteries (see Chapter 11).

The term Storage Battery is actually a misnomer. It doesn't actually store electricity at all, but rather creates it by changing chemical into electrical energy while discharging. If we consider the typical automotive battery (a lead acid battery) it consists of a positive electrode of Peroxide of Lead (shown chemically as PbO_2) a negative electrode of pure Lead (Pb) and an electrolyte of dilute sulphuric acid.

At the positive electrode Lead Peroxide and Sulphuric acid produce Lead Sulphate, water and oxygen, which is depicted as

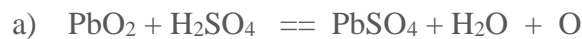

At the negative electrode Lead and Sulphuric Acid produce Lead Sulphate and Hydrogen, or

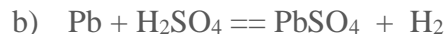

The oxygen of equation a) and the Hydrogen of equation b) combine to form water. If we combine the two equations we get:

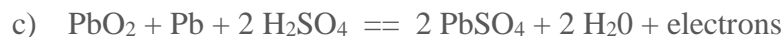

This reads as one part of Lead Peroxide (PbO_2) + two parts of Sulphuric Acid (H_2SO_4) yield two parts of Lead Sulphate ($PbSO_4$) + two parts of water (H_2O). Electrons are released during the reaction creating the electrical current.

If we now connect the spent cell to a generator and send an electrical current through the cell in reverse, the Lead Sulphate will be changed back into Lead, Lead Peroxide and Sulphuric Acid at the positive electrode, depicted as:



At the negative electrode Lead Sulphate and water produce Lead, Sulphuric Acid and Oxygen, which is depicted as:

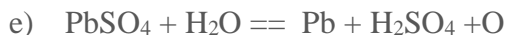

Again the Hydrogen from equation d) combines with the Oxygen of equation e) to form water. Combining the equations yields:



Which returns the battery to its original state, ready for use.

None of these reactions occur instantaneously, but rather, over a period of time. The rate of discharge and charge is affected by the flow of electrical current. In layman's terms a 100 watt bulb draws more current than a 60 watt bulb, resulting in a shorter battery life.

Similar reactions occur in the Leclanche Cell, which uses electrodes of Zinc and Manganese Dioxide with an electrolyte of Ammonium Chloride. The reaction there is Zinc, Manganese Dioxide and Ammonium Chloride produce Zinc Chloride, Manganese Oxide, aqueous Ammonia, water and electrons.

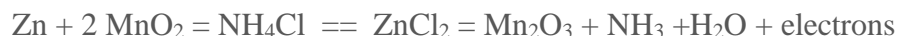

All reactions are in a liquid, with little gases released. This battery had some drawbacks which were discussed earlier. On the positive side, when the battery was idle the reactions would reverse, automatically recharging the battery.

The reactions in the Edison Battery which used electrodes of Nickel Oxide and Iron with a Potassium Hydroxide electrolyte are: Nickel Oxide, Iron, and Potassium Hydroxide produce Nickel Hydroxide, Iron Dioxide. Unlike the other batteries, the Potassium Hydroxide does not react, and is not consumed.

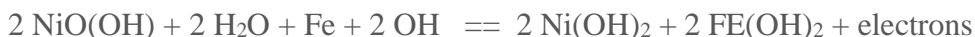

The reactions in the Edison Battery progressed very slowly, limiting its strength. Of the three batteries mentioned, the Lead-Acid is the most robust.

6.3 BATTERY JAR SIZES

Battery jars were available in various sizes and shapes. You will notice, as you study the information within these pages, that many battery jars, particularly the larger square and/or rectangular ones were available in a myriad of sizes. There seemed to be no attempt to standardize on size. The smaller cylindrical or square jars, which, in appearance, resemble a quart jar without the threaded top, I have termed “*Quart*” size. They have a diameter of 3 - 5” and a height of 5 - 8”. You will find a few slightly outside of these ranges, but not many. They came with either a ground or finished lip, depending on when they were manufactured. Some had a pour spout. The electrodes could be flat or cylindrical. Most of these jars were embossed with the name of the customer, rather than the manufacturer. Only a few jars seem to have been embossed with the name of the manufacturer, and even then, most were not so embossed. It is known that the following glass houses did emboss their name on a few of the jars they manufactured; typically on the bottom.

Hemingray Glass Co.
Corning (Pyrex)

Whitall Tatum Co.
Gayner

Then you have the Farm size batteries. These are the large square and/or rectangular jars, generally with a formed lip and a sealed lid. These will not have an Electric Co name embossing, but rather the name of the major brand that manufactured them, such as: Delco, Universal, Exide, Gould, Grant, Willard, etc. These batteries seemed to not have standard sizes. As you go through these pages, you will be amazed to find that they were available in sizes that differ by only an inch or two in size. In an attempt to illustrate this I have extracted size information from the jars presented in this work.

And then there are what I call “specialty batteries”, manufactured for a specific company for a specific purpose. You will recognize these as you read through the chapters, as they don’t conform to the “quart” size; nor do they conform to the large size and shape of the Farm battery. Specialty batteries are generally small, sized by oz., or unusually shaped. It is known that Whitall Tatum manufactured Specialty Batteries, with many used in medical batteries or similar applications. See Chapter 2 on Medical batteries. The technical name for these batteries is the Poggendorf cell, often referred to as the Grenet cell.

We have to remember that a lot was happening at this time. As we learned to make and harness electricity, batteries were called upon to power many things eg. home radio, door bells, radios, phonographs and a myriad of other home related items. Most electrical devices you could name were powered by batteries, i.e., battery jars, as AC current was not wide available until the early 1900s. The Pan Am Exposition in Buffalo, NY in 1901 was the first demonstration of AC current.

The development of the battery also spawned the growth of electricity in the medical industry. Chapter 2 is a more detailed discussion of medical batteries.

Many glass companies that provided battery jars, etc, published sales catalogs. Where possible I have had these catalogs placed on the NIA web-site (Members Only). To date The ESB Co and Northern Electric Co. offered complete lines of not only battery jars, but also associated

equipment. The jars were manufactured by some glass house. To highlight the extent of this industry, I extracted parts of the Electric Storage Battery Co. (ESB) catalog and placed it in its own chapter (17).

It is important to keep in mind that advancements in electricity were not slow moving. This was a very dynamic time. The companies at the forefront of this industry were generally incorporated in the last quarter of the 1800s. By the turn of the century we had the first dry cells. The Chloride of Silver Battery Co., of Baltimore Maryland was one of the first to offer dry cells. National Carbon's Eveready brand was also introduced about this time. Electroplating equipment was offered in catalogs as early as 1890.

Whereas, in Volume I everything is grouped under the Primary Embossing, In Volume II everything is grouped under major headings, sub-groups by embossing.

6.4 BATTERY JARS: DEFINITIONS & TERMINOLOGY

- The most important part is the set of positive and negative plates. As discussed earlier (page 9), the number of plates was always an odd number because of the spacer needed between the positive and negative plates. Common numbers of plates ranged from 1 to 17. Specialty batteries had as many as 33 plates, or more.
- Battery Bridge Rests. Usually these were an integral part of the jar, but if not, the bridge was placed on the floor of the jar to support the plates. All battery reactions produced debris which would fall to the bottom. The Bridge Rests supported the plates from the bottom to prevent the debris from building up and shorting the plates.
- The Battery Cell Cover was a lid that covered the jar. We have seen screw-on lids as well as lids that simply rested on top of the jar. On Farm batteries they were glued to the jar with a tar-like substance to prevent leaks.
- Floating Battery Post Bushing: Over time the positive post grows upward, which could cause damage. The floating bushing grew upward at the same rate as the post, thus preventing damage.
- Battery Vent Caps: All lead-acid batteries form gas, usually during charging. If allowed to build up, it could cause damage or even an explosion. The vent cap releases any gas pressure build-up from the battery as it is formed.
- Battery: Two or more electrical cells, electrically connected so that they furnish current as a unit.
- Cell: The battery unit consisting of elements, with electrolyte, in jar with cover.
- Electrolyte: The conducting fluid of electro-chemical devices; for lead acid batteries it consists of about two parts of water to one part of chemically pure sulphuric acid, by weight.

- Jar; The container holding the elements and electrolyte; typically glass and/or hard rubber, and later, plastic.
- Sediment: Loosened or worn out particles of active material that has fallen to the bottom of a cell, frequently called “mud”.
- Short Circuit: A metallic connection between the positive and negative plates within a cell. The plates may be in actual contact or material may lodge and bridge across. If the separators are in good condition and mud is not allowed to build up in the bottom of the jar, a short circuit is unlikely to occur.
- Terminal: The part to which outside wires are connected.
- Corrosion: The attack by acid from the electrolyte on surrounding materials.
- Evaporation: the loss of water from the electrolyte caused by heating and charging.
- Gassing: The formation of Oxygen gas at the Cathode and Hydrogen gas at the Anode , which starts when the charge about half finished, depending on the rate of charge
- Post: A part extending through the cell cover, allowing connection of the elements to the terminal.
- Battery Edge Protectors: Are boots that cover the bottom edge of positive or negative battery plates. This prevents damage that may occur during manufacture to ensure a longer battery life.
- Battery Plate Protectors: are a thin shield that covers the top of the battery plates to prevent mousing. Mousing is the build-up of particles on the top edge of battery plates, which can cause a short circuit between the plates.
- Battery Vent Caps: allow gasses that build up during charging to vent harmlessly.

7 Battery Oil Bottles

No discussion of battery jars would be complete without some mention of battery oil. The battery oil and the bottles it came in could be called associated equipment, as it was essential for a successful battery. Immediately, when oil is mentioned, we tend to think of lubrication. Battery oil is different. The "battery oil" was poured on top of the fresh electrolyte in each cell to prevent evaporation and gassing while charging on these utility poles. The oil would float on top of the electrolyte to give a thick protective oil film. This would help the battery gases to recombine instead of gassing-off while sitting long term, or re-charging. It also prevented evaporation. You often find empty Edison Battery Oil bottles of 3-4 oz. size, near old railroad iron signal & switch boxes in the woods near the switch & signal boxes today.

The railroad workers would use the oil and then just toss the empty bottles in the woods alongside the tracks.

I am extremely grateful to Rick Turner for sharing his Battery Oil bottle collection: I had no idea that there was so much to Battery Oil bottles until I received the information from Rick. With one exception, this entire chapter is courtesy of **Rick Turner**.



←**7.1**: Is a 6 oz. Edison bottle. It is light green aqua; 2.25” diameter x 5.675” tall. It is a blown in mold bottle with a hand tooled lip. Embossing appears to be hand script. Actual embossing is: **(Front) Trade / THOMAS A. EDISON (script) / Reg. U.S. Mark Pat. Off./ 6 OZ. / Special / Battery Oil / Thomas A. Edison Inc. / Orange, N.J. U.S.A. (Base) C-6**

We know that a 2oz. and a 5oz. bottle with the exact same embossing as **7.1** and **7.2**, exists. Both are Aqua and blown in mold.



7.2↑ Shows three – 4 oz. Edison bottles. The two on the left are aqua, while the one on the right is SCA. They are all 2” diameter x 4.875” tall. Like 7.1, they are blown in mold with hand tooled lips, and with what appears to be hand script. Actual embossing is as follows: **(Front) TRADE / Thomas A. Edison (script) / Reg. U.S. TRADE Pat. Off./ 4 oz. / Special / Battery Oil / Thomas A. Edison Inc. / Orange, N.J. U.S.A. (Base) C-4.**

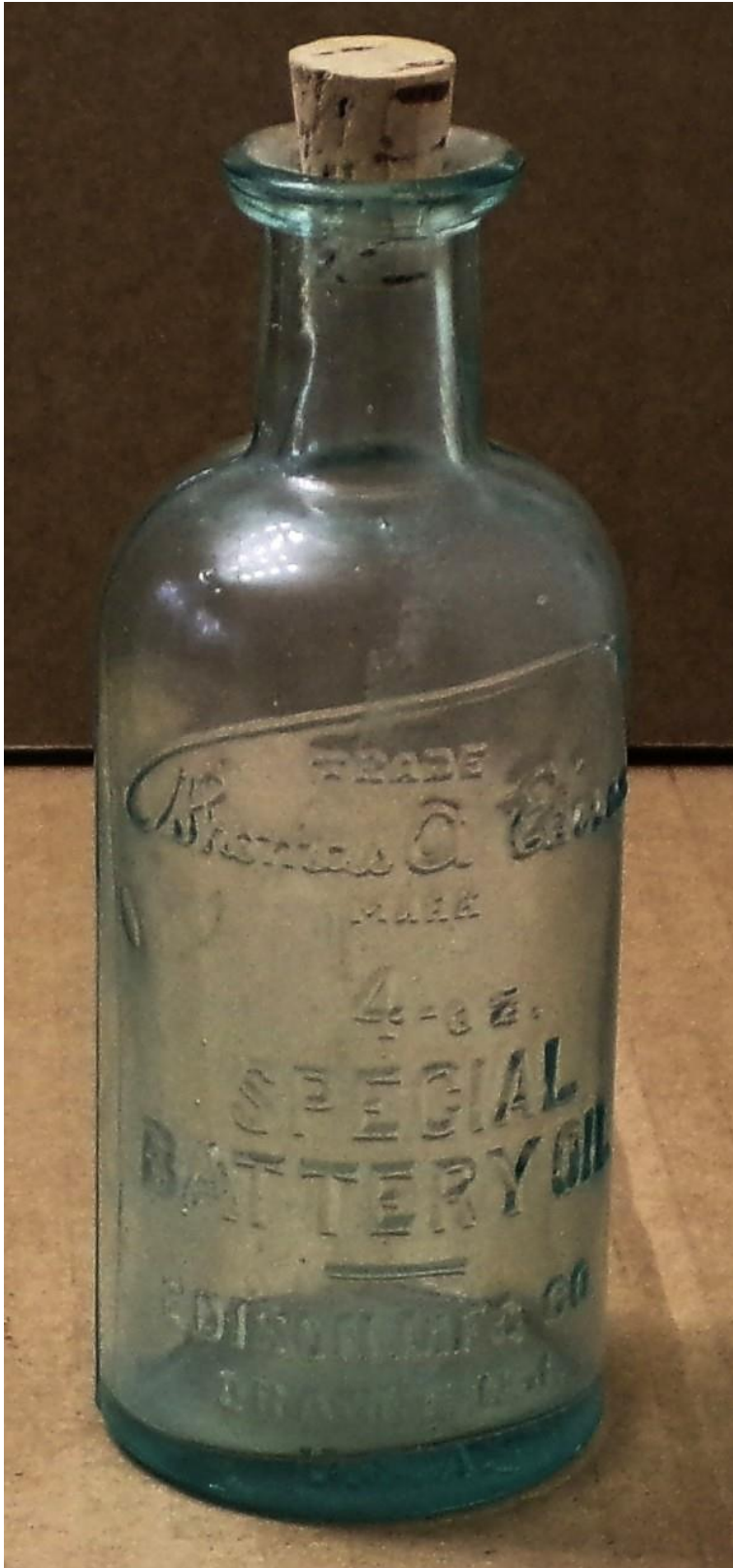

←7.3, is a 4 oz Edison bottle with embossing variation. It is aqua; 2” diameter x 4.875” tall. Like the others it is blown in mold with a hand tooled lip. Embossing does not appear to be hand script as in 7.1.1 and 7.1.2.

Actual embossing is as follows:
Trade / Thomas A. Edison
(script) / Mark / 4 – oz. SPECIAL
/ BATTERY Oil / Thomas A.
Edison Mfg. Co. / Orange, N.J.
U.S.A.

Note: Differences from other 4- oz. bottles:

1. No Reg. U.S. Pat Off.
2. It is EDISON Mfg. Co. rather than THOMAS A. EDISON, Inc.

\



←7.4, is a rare paper label Edison bottle. It is a 4 oz., aqua bottle, sealed with tar. It is 2" diameter x 4.875" tall; blown in mold with a hand tooled lip. The Label reads: **TRADE MARK / Thomas A. Edison (script) / SPECIAL BATTERY OIL / to be used only in / EDISON PRIMARY BATTERY / charge for one cell types Q, S, SS or V. Pour Oil on Solution after / Soda is thoroughly dissolved. / Manufactured By / EDISON MANUFACTURING CO. / Orange, N.J., U.S.A. (Base) either 6 or 9.**

The bottle is rare for two reasons:

1. It is full and sealed.
2. It has an intact paper label.



7.5↑ shows four 3 oz. Edison bottles. The colors are aqua, clear and a light cornflower blue. They are all machine made, 1.25" diameter x 4.375" tall. The bottles are embossed: **Trade / Thomas A. Edison (script) / REG. U.S. Mark Pat. Off. / 3 – oz. / Special / BATTERY OIL / Thomas A. Edison Inc., Orange, N.J. U.S.A.**



←**7.6** is a rare Australian, machine made, Edison oil bottle. The color is clear and its dimensiona are: 1.675" diameter x 4.675" tall. Its embossing appears to be hand script, and reads: **3 oz. / SPECIAL BATTERY / OIL / Thomas A. Edison Ltd. / Sydney / N.S.W.** Courtesy of Rick Turner.
A 4 oz. aqua bottle, with the exact same embossing exists.



←7.7 are the front views of Edison flask style bottles, of which there are three variations. All are from after the Edison plant burned and it was moved to Bloomfield, N.J. This is the oldest style, in aqua and clear. Exact embossing is: **(front) SPECIAL / BATTERY OIL / Edison / Primary Battery / Division / Thomas A. Edison Inc. / Bloomfield, N.J.**



← 7.8 is the rear views of 7.1.7. The embossing is vertical; as follows: **Trade / Thomas A. Edison / Reg. U.S. / Mark Pat. Off.**

The bottles are 1.125 x 1.06 x 4.75" tall. Note the seam band midway in the neck.

←**7.9** is the front view of the second style of Edison Flask bottles. Embossing is as follows: **(Front) SPECIAL / BATTERY OIL / THOMAS A. EDISON / INCORPORATED / PRIMARY BATTERY / 6DIVISION / BLOOMFIELD, N.J. U.S.A.**



7.10 is the rear view of **7.0.9**: Embossed as follows: **TRADE / THOMAS A. EDISON / Reg. U.S. MARK Pat. Off. / Made in U.S.A.**

The bottle is 1.125 x 2.25 x 4.5" tall. The base is embossed 380 <W/T> 4

Note: I have this exact bottle in clear galss. On the base is **836 / T (in inverted Triangle) / 10**. The logo is for Turner Bros. of Terre Haute, IN. (1910-1929).



7.10↑



7.11 and 7.12 are the front and rear views of the third and final style of the Edison flask style battery oil bottle.

It is clear glass with embossing as follows:
**(Front) EDISON / BATTERY OIL /
Made in U.S.A. / Thomas A. Edison /
Incorporated / Bloomfield, N.J. / U.S.A.**

The reverse is simply Thomas A. Edison
(script)

The bottle is 1.125 x 2.25 x 4.5" tall. The
base is embossed **14 <O> 1.**

←7.11

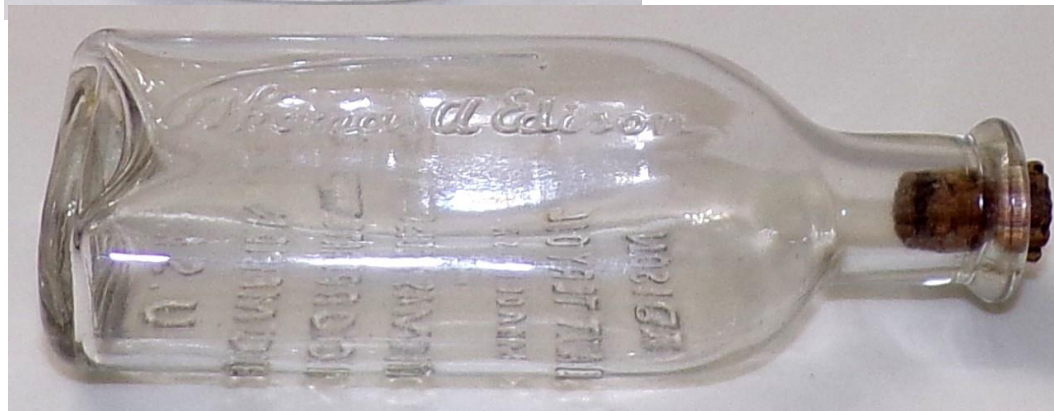

←7.12



7.13↑ shows three Edison crown top battery oil bottles. They have the Coke bottle style closure and come in clear and light green

The embosing is as follows: **EDISON / BATTERY OIL / Made in U.S.A. / Thomas A. Edison / Incorporated / Bloomfield, N.J. / U.S.A. (Reverse) Thomas A Edison.** The dimensions are 1" diameter x 4.125" tall.

The middle bottle is an unembossed Edison Bottle.



←7.14 is a clear bottle with the Crown closure.

It is embossed as follows:

BATTERY OIL / National Carbon / Company / A Division of / Union Carbide / and Carbon Corp. / 30 East 42ND ST / New York 17, N.Y. / MADE in U.S.A. NOTE: the early 2 digit Zip Code The dimensions are 1.5" diameter x 4.125" tall.

The base is embossed with an oil derrick. Others have been found with a keystone.

Note: The 2 digit zip code was introduced during WWII and discontinued in 1963 in favor of the 5 digit code.



7.15↑ shows two variations of a Waterbury embossing. Both are clear glass with crown closures. The bottle on the left is embossed: **WATERBURY / BATTERY OIL / The Waterbury Battery Co. / Waterbury, CONN / U.S.A.** The dimensions are 1.5” diameter x 4.125” tall.

The bottle on the right has the same embossing except the location is **Plainview, CONN.**



←**7.16** is simply embossed **BATTERY / OIL**. The base has the number 15 and an oil derrick. It is clear glass with the crown closure. Its dimensions are 1.5" diameter x 3.625" tall.



7.1.17↑



7.1.18↑

←7.17 and ←7.18 show a porcelain battery oil jar, with a red glaze. It's dimensions are 1.5" diameter x 4.5" tall. It is embossed:
Trade / Thomas A. Edison (script) / Reg. U.S, Mark Pat. Off. / 3-oz. / SPECIAL / BATTERY OIL // Thomas A. Edison / Orange, N.J. / U.S.A. Courtesy of Tommy Bolack



←7.19 is a battery oil bottle that seems to have been made for 6 – cell batteries. The side is graduated equally into 6 sections, embossed First Cell, Second Cell, etc. through Sixth Cell. It is 1.25" in diameter x 6.25" tall. It, too, is Courtesy of Tommu Bolack



7.20↑ shows two clear battery oil bottles, with no idea of where they came from. The one on the left is simply embossed **2 ½ FL. OZ.** the base is embossed **O-I** in a diamond with numbers. The one on the right is embossed on the lower lip "**Prior Patented Registered 2 ½ FL. OZ.** It base, too, has **O-I** in a diamond with numbers. They both have the crown cap closure and were obviously manufactured by Owens-Illinois. Both bottles are 1.625" diameter x 4.375" tall.



←7.21 is unembossed except for "609" on the base. A paper label reads "**EDISON / OIL / T.E. EDISON, MC. / ORANGE / N.J.**" The bottle is tall & narrow, measuring 1: diameter at the base and 1.25" diameter at the top. It stands 5 1/2" tall. Courtesy of Bob Berry

8.0 BATTERY RESTS

The following excerpt from “*Battery Insulators, Oil Insulators and Chloride Accumulators*” by Charles and Sandy Irons (with permission) describes the need for and the use of Battery Rests.

“From the first time that a cell or battery was used to supply electricity a way was needed to prevent or reduce the leakage of electric current. This leakage occurred, when, over the surface of the cell or battery (and the support that it was placed on) became coated with a fine deposit of acid-laden moisture and dust”.

It was found that electric leakage was reduced if each cell or battery (a series of cells) was isolated from the support on which it sat.

Wood framing was used, but it was discovered that, over time, the wood would absorb the acid-laden moisture and created a direct path for electrical leakage, and eventually the acidic moisture would cause the wood to rot.

Battery Insulators were used with DC electric systems as low as 1 – 2 volts and up to 600 volts and greater.

Lower DC voltage was used for a short time with telegraphs, alarms, and railroad signals. Higher voltage was used for lighting motors, pumps, etc. Originally, plain glass battery insulators were placed between wooden stringers and the battery tank. This proved to be insufficient ... so, glass insulators were added between the wood stringers and the floor. This combination became known as “Double Insulation.

However, this did not prevent the decay of the wooden stringers ... so the Electric Storage Battery Co, (E.S. B. Co.) designed and developed the combination of an oil insulator and an earthenware pedestal that solved the problem of the wood decaying. This earthenware pedestal / oil insulator became the standard for the industry and made it possible to do away with the wooden stringers.



← **8.1** shows the complete pedestal / Oil Insulator unit ... consisting of cupped lead washer, Y lead insulator, oil insulator and the insulator pedestal.

This pedestal assembly was used to support a battery tank that was constructed of wood and lined with lead. The exterior was lined with asphaltum. Four to six CD-35s or CD-36s were used to support this style of battery tank. **Note:** The uneven base, which allowed water and foreign material to pass under the support when flushing the battery room floor.”



← **8.2** shows a CD 35 / CD 36. These battery insulators are unique because they were filled with a non-conductive oil that was put in the circular trough and was then covered with a lead-alloy cap. The purpose of the cap was to exclude, as far as possible, all spray or other foreign material from getting washed into the oil space and to prevent it from being splashed when flushing the battery room floor.”

Battery rests came in all shapes and sizes. I included examples in pictures **8.3 through 8.5**.



8.3↑ is CD 22 (2” diameter x 1” tall)



←**8.4** is CD – 20) 2” diameter x 1.25” tall)



8.5 is

The following major embossings have been found on battery rest insulators:

- The E.S. B. Co.
- Gould
- National Battery Co.
- U.S.L. & H. Co. (U.S. Light & Heating)
- Ware
- Chloride Accumulator
- M.T. Co

From dump digs we know they were manufactured by the following companies, most of which were major insulator glass houses.

- Brookfield (Gould, No Embossing, U.S.L.)
- Hemingray (U.S.L. & H. Co., National Battery Co., No Embossing)
- Elmer Glass Co. (No Embossing, E.S.B. Co.)
- The E.S.B. Co.
- Gould Storage Battery Co.
- U.S.L. Battery Co.



← **8.6** shows a picture of the 3-piece Gamewell Battery Support Insulator.

The entire texts of Battery Insulators, Oil Insulators and Chloride Accumulators by Charles & Sandra Irons; and a similar article in Bottles and Extras, also by Charles & Sandra Irons, are found in Appendix A and Appendix B, respectively. The complete article on the Gamewell system, by Elton Gish, is in Appendix C. It was in the Winter 2019 Issue of ALL INSULATORS Crown Jewels of the Wire.

I have added, here, what I believe may be an unlisted Battery Rest. (8.7 through 8.10).

8.7↓



8.8 ↓



8.9↑

8.10↑



The slots on the bottom would have fit over a support system of some kind, perhaps like the Gamewell system.

9 BATTERY TRAYS

The acid-laden moisture issue was also dealt with by using Sand (Battery) trays. The batteries were placed on shallow trays that were filled with sand. The acidic moisture that ran down the sides of the battery jars were collected in the sand, thus protecting the wooden supports. Initially the trays were constructed of wood that was covered in lead. Later glass trays were used. The E.S.B. Co. is the only manufacturer of glass trays, I've found.



← **9.1** is a page from the ESB Catalog of 1906. It shows open battery jars sitting on trays, which, in turn, are sitting on battery rests. Note how closely the size of the trays fit the battery jars.

**Glass (Sand) Trays for the
Chloride and Tudor Accumulators***

<u>Type</u>	<u>Dimensions (in.)</u>	<u>Catalog #</u>
C-3	3 ½ x 5 ¼	9250
C-5	4 ¼ x 5 ¼	9250
C-7	5 ¼ x 5 ¼	9250
D-3	3 7/8 x 7 3/8	9254
D-5	5 3/8 x 7 3/8	9254
D-9	8 ¼ x 7 3/8	9256
D-11	9 ½ x 7 3/8	9256
D-13	11 x 7 3/8	9258
E-5	5 7/8 x 9 1/8	9259
E-7	6 ¾ x 9 1/8	9260
E-9	8 ¼ x 9 1/8	9260
E-11	9 ½ x 9 1/8	9262
E-13	11 x 9 1/8	9262
E-15	12 ¼ x 9 1/8	9269
F-9	8 ½ x 12 3/8	9265
F-11	9 ¾ x 12 3/8	9265
F-13	11 x 12 3/8	9265
F-15	15 ½ x 12 3/8	9268

*This data is extracted from the 1906 catalog of CHLORIDE ACCUMULATORS by the Electric Storage Battery Co. of Philadelphia, listing the dimensions and other information on the battery trays they provided.

Following are the glass battery trays I've identified:



←**9.2** is embossed **E.S.B. Co. No. 5**
 // **Made IN U.S.A.** Note the BK Ns.
 Its dimensions are 6.75" x 10". It is
 Uranium Glass. **Courtesy of Walt
 Baumgardt.**



←**9.3 and 9.4** show an **E.S.B. Co.**
No. 5, With Normal Ns. **Courtesy of
 Tommy Bolack.**



← **9.4**



←**9.5** is embossed **E.S.B. Co. No. 7-5**
 // **Made IN U.S.A.** Note the BK N.
 Its dimensions are 10.25" x 13.5". It is
 Uranium Glass. **Courtesy of Walt
 Baumgardt.**



←**9.6** is embossed **E.S.B. Co. No. 7** // **MADE IN U.S.A.** Its dimensions are 10.25 x 12.125. It is Uranium glass. Note the Normal Ns. **Courtesy of Tommy Bolack.**



← **9.7** is embossed **E.S.B. Co. No. 7-1** // **MADE IN U.S.A.** Its dimensions are 10.5" x 13.5". It is Uranium glass, also. Note the Normal Ns rather than BK Ns. **Courtesy of Tommy Bolack.**



←**9.8** is embossed **E.S.B. Co. No. 6** // **Made IN U.S.A.** Its dimensions are 9.25" x 10". Note the BK Ns. It is Uranium Glass. **Courtesy of Walt Baumgardt.**



←**9.9 and 9.10** is another another **ESB Co. No. 6** tray. Note the Blotted embossing on one side and the Normal Ns. Rather than Uranium glass, this is a light SCA. **Courtesy of Tommy Bolack.**



← **9.10**

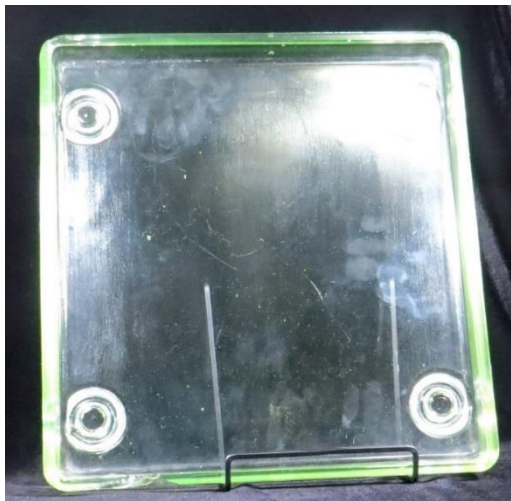

←**9.11** is embossed **E.S.B. Co. No. 9 // Made in U.S.A.** Note the BK Ns. Its dimensions are 12.5" x 13.5." **Courtesy of Walt Baumgardt.**



←**9.12** is embossed **E.S.B. Co. No. 2 / Made in U.S.A.** Its dimensions are 7.5" x 9" and is light SCA. **Courtesy of Nick Bergkessel.**

The following notes summarize the embossing, embossing errors and colors of the battery trays identified to date. All were manufactured by The E.S.B. Co. See a few details on the company, below.

<u>Model #</u>	<u>Size (in.)</u>	<u>Top</u>	<u>Bottom</u>	<u>Color</u>
E.S.B. 5	6.75 x 10	E.S.B. No. 5	MADE IN U.S.A.	Uranium
E.S.B. 5	6.75 x 10	E.S.B. No. 5	MADE IN U.S.A.	Light SCA
E.S.B. 6	9.25 x 10	E.S.B. No. 6	MADE IN U.S.A.	Uranium
E.S.B. 6	9.25 x 10	E.S.B. No. 6	MADE IN U.S.A.	Light SCA
E.S.B. 7 - 5	10.25 x 13.5	E.S.B. No. 7-1	MADE IN U.S.A.	Uranium
E.S.B. 7	10.25 x 13.5	E.S.B. No. 7-1	MADE IN U.S.A.	Uranium
E.S.B. 7 - 1	10.25 x 13.5	E.S.B. No. 7-1	MADE IN U.S.A.	Uranium
E.S.B. 9	12.5 x 13.5	E.S.B. No. 9	MADE IN U.S.A.	Uranium
E.S.B. 2	9 x 7.5	E.S.B. No. 2	MADE IN U.S.A.	Light SCA

Notes:

- Note the mix of normal and BK Ns.
- The heights of the trays vary from 1.5 – 1.75.”
- Each tray has four short legs (0.375”).
- The Vaseline trays (also known as Uranium glass), glow under black light.
- Embossing is on top of the front and rear lips.

You will notice that none of the sizes seem to match any trays from the E.S.B Co. catalog. It is unknown why this is so.

It is likely that other companies manufactured battery trays, but to-date all the trays found have been manufactured by the Electric Storage Battery Company. The predecessor to Exide Corporation, it was founded by W.W. Gibbs in 1888. Gibbs purchased the ideas and patents of inventor Clement Payen to make the storage battery a commercial product. A copy of the ESB catalog from 1906 can be found in the members only section of the NIA web site. They are listed as manufacturers of wet cell batteries.

In 1893, the Electric Storage Battery Company produced chloride accumulators for stabilizing electric grids.

In December of 1894, W.W. Gibbs, president of ESB CO, stated that the company had completed the purchase of all patents and patent rights concerning the manufacture and use of electric storage batteries of the General Electric Co., The Edison Co., the Thomas-Houston Co., the Brush, the Accumulator company, the Consolidated Electric Storage Co. and the General Electric Launch Co. Mr. Gibbs assured everyone that this gave the Electric Storage Battery Co. exclusive rights to supply the country with electric storage batteries of the various types previously developed, as well as the protection of every decision rendered by the federal courts in the interpretation of patents of this kind.

The E.S.B. Co. went on to install over 500 power plants for Trolleys across the U.S. (See Chapter 24).



9.13↑ is believed to be a previously unknown small battery tray. It was found in cleaning an old building that was known to have housed many battery jars. It would have been for a rather small battery jar as the overall dimensions are 1.5: x 4" x 0.5" thick, with a lip of 0.125".

10 ELECTRIC VEHICLES (EVs)

We've all heard the adage "What Goes Around, Comes Around," and this is certainly true of Electric Vehicles (EVs). The evolution of the automobile and more specifically, the power plant driving the automobile, is most interesting.

In 1900, steam vehicles accounted for 40% of the U.S. automobile market, EVs accounted for 38% and the internal combustion engine 22%. At the same time less than 3% of homes in the U.S. had access to electricity. Thomas Edison was convinced that EVs were the future of the automobile. He spent the equivalent of \$35 million to develop a usable battery for EVs. Ironically, both Henry Ford and Nikolai Tesla both worked for Thomas Edison early in their careers. Although Edison and Tesla had a strained relationship at best, Edison and Ford were best friends, vacationing together and even buying vacation homes next door to each other in Florida. As late as 1914, Ford and Edison announced their desire to market an EV weighing approximately 1,100 pounds with about 405 pounds of battery equipment and priced at \$600.

It is easy to blame Edison for his failure to provide a suitable battery, but to understand exactly why EVs lost out to the internal combustion engine, we need to understand some of the underlying issues of the time.

- Storage batteries were still being developed.
- The Edison battery was extremely costly, which led to the dominance of the lead acid battery.
- Henry Ford insisted that EVs must use Edison batteries. It is said that he fired employees for experimenting with the lead acid battery behind his back.
- Battery problems plagued Edison during this period.
- Edison EVs built at the time sold for \$1,200, more than 4 times the price of a Model T at the time.
- WWI played a role in the decision. At the time, the U.S. was gearing up for war, and with batteries still under development and no charging stations, EVs made no practical sense. The same scenario exists today. Most of the country does not have the infrastructure of charging stations to support EV's. It is a classic case of "Which Came First-The Chicken Or the Egg?"
- Major oil discoveries in Texas in the early 1900s led to a cheap source of fuel and eventually a major lobby against EVs.
- Edison finally perfected a long-life durable battery the Edison A, a Nickel-Iron rechargeable battery with a Lithium Hydrate electrolyte additive, which was not perfectly understood until the 1950s.
- Unfortunately, "the Edison A" was available for sale a year after the Ford Motor Co. introduced its low cost, high mileage Model T gas powered automobile for the masses.
- The normal disadvantages of electric motors made them perfectly suitable for city travel. Streets weren't built for vehicles travelling faster than 20 mph, and horses and trains were still preferable for long trips. The very limited mileage range 25 – 30 miles for EVs was a non-issue at the time.

As you can see there was not a single thing that ultimately led to the choice of the Internal Combustion Engine over EVs but rather many things coming together at the same time. Despite its seeming failure at the time, the Edison battery became Edison's most profitable invention, gaining wide adoption in mining lamps and railway signaling.

So, here we are 120 years later, and EVs are again the wave of the future. Seemingly, “what goes around, comes around”. Ford Motor Co. has announced that 10 -25% of its fleet will be electrified, in some way, soon. Ford is also working on a fast, Mustang-inspired EV. Ironically, the name of the 55-person team is “**Team Edison**”.

Early automotive batteries, by today’s standards, were large, cumbersome and fragile (using glass battery jars). **10.1** shows a typical automotive battery of the day. Note the size of the battery.

(10.1)↓

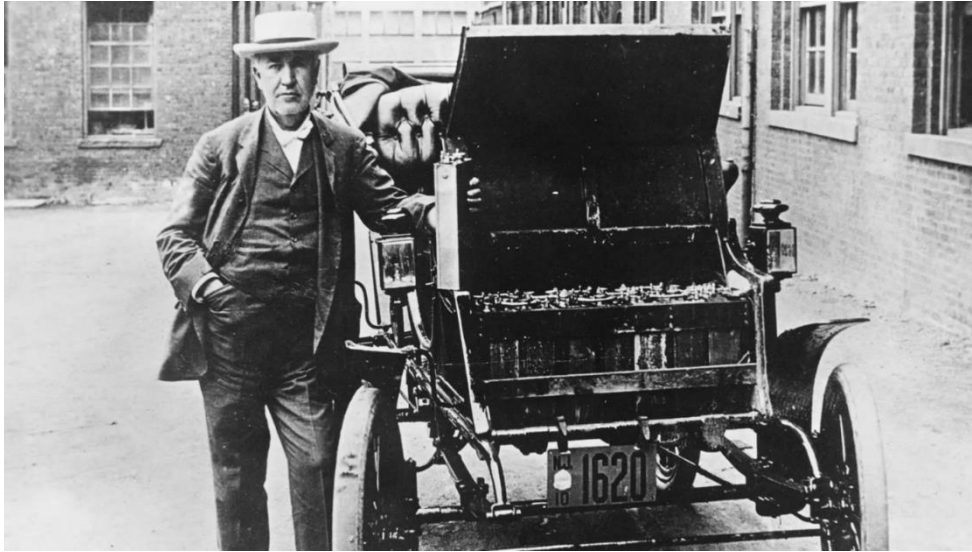

The Edison EV had two 15-volt batteries and a 30-volt electric motor, with a top speed of 25 MPH. Most EV’s of the day had approximately 45 cells in the battery

Fig. **10.2** (below) shows the 1914 Ford Electric Vehicle. Note the large amount of space consumed by the batteries In front of the driver and under the driver’s seat.



10.2↑



← 10.3



← 10.4

10.3 and **10.4** show an early automotive battery. It is a three cell unit of Uranium glass with O.D. dimensions of 4.5" x 10.5" x 6" tall. Each cell has I.D. dimensions of 3" x 3.5" x 6" tall. The glass is totally un-embossed. The cells are connected in series, with PHILCO on the connections. **Courtesy of Tommy Bolack.**

At the turn of the century there were several manufacturers of Electric vehicles. For those that are interested, I have attached a listing of the available EVs in 1905 with a few statistics on each in Appendix 4. The source is www.lowtechmagazine.com/overview-of-early-electric-cars.html.

Two person vehicles sold for \$800 - 2,000.00 and had an average of 24-30 cell batteries.

Vehicles with the capacity to hold 3 or more people sold between \$3,500 and \$6,000.00, with an average of 40 cell batteries.

11 FARM AND HOME BATTERY SYSTEMS

I was surprised when I found that battery jars were still being manufactured in 1940. Further research showed that in 1930, only 10% of rural America had electrical power. After the Great Depression, one of the New Deal Programs was the Rural Electrification Act I (REA) whose purpose was to provide low cost loans to rural cooperatives to generate and distribute electrical power to rural areas. President Roosevelt started the program 1935, and progress was slow. It was not just a simple matter of providing electrical power. Most people in rural America had never seen electricity. They knew nothing about it and were likely afraid of it. Along with the generation and distribution was the educational process to overcome peoples fears and to teach them how to use it. By 1944, 50% of rural America was still without electrical power.

From 1915 to the 1950s, rural America relied on stand alone power plants supplied by one of several manufacturers. Batteries were assembled in arrays similar to the ones shown below, in order to power farms and or large buildings. Large arrays, like this, were necessary in order to produce the power necessary to power a farm and/or home.

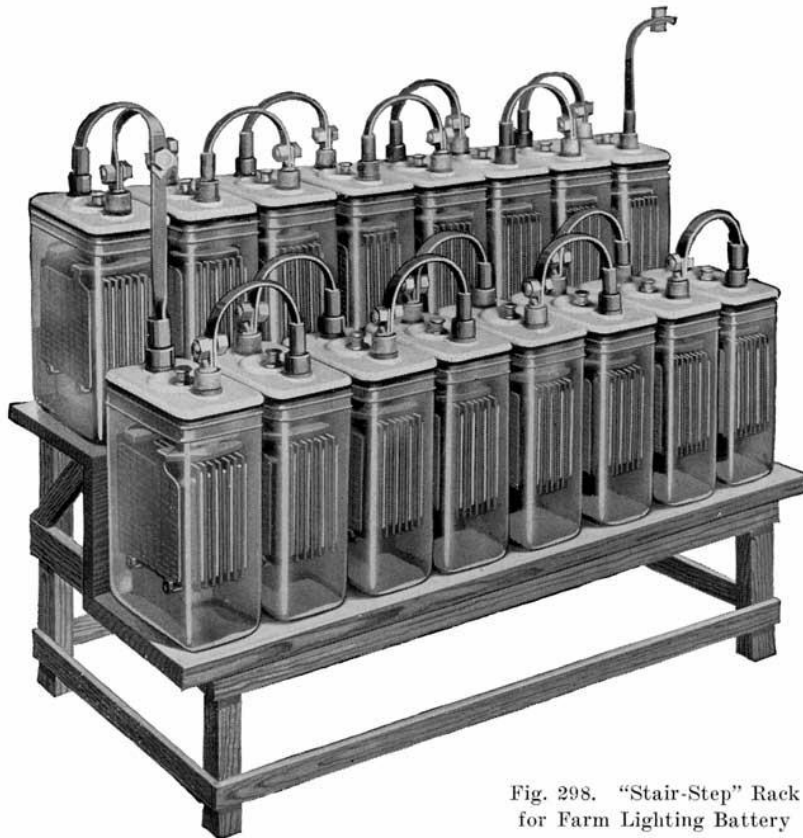
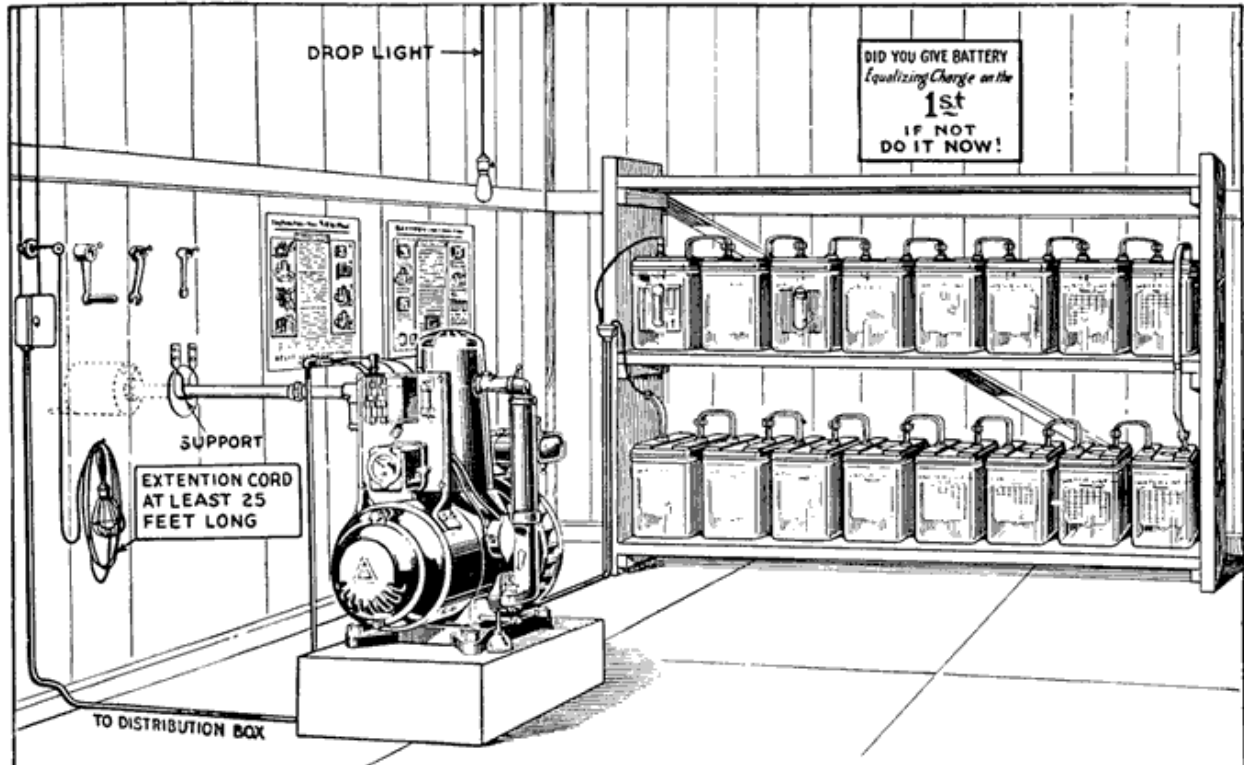

Fig. 298. "Stair-Step" Rack
for Farm Lighting Battery

The battery arrays were one of two designs. The Stair-Step seen in

←**11.1** or the Two Tier seen in **11.2 (below)**. The Stair step was the preferred arrangement as it prevented the acidic moisture from dripping onto the lower rack of batteries. Many times space dictated which was used.



11.2↑ Two Tier Battery Array

Farm battery systems were sent directly from the manufacturer to the Farm. If sealed units had been ordered, the individual would arrive assembled already charged with the electrolyte (Sulphuric Acid). If sealed units had not been ordered, all components were shipped separately and assembled on-site, including charging the electrolyte. Even sealed units developed leaks from time to time. Using the preferred “stair-step” installation prevented any leakage from dripping onto the batteries below. Generally, Battery (Sand) trays were used under the individual units to contain any leaks (The details of acidic moisture and battery trays was discussed in Chapter 9).

Delco provided the first such system (Delco Light Plant) in 1915 and within a few years was dominant in the market. The Delco Light offered 25 models, capable of producing 500 to 3,000 watts of power. The large lead-acid storage batteries had clear glass cases and were arranged in banks of 16, as shown. (11.2) The system included an internal combustion engine for recharging the system. The installed cost for a 750 watt system was about \$950.00 (over \$15,000 today).

Selling these units must have been a salesman’s dream, arriving about dusk with a portable system, which he set up and brewed coffee while the room was lit with other than candles.

Other companies supplying such systems are seen on the following pages with examples of their battery jars.

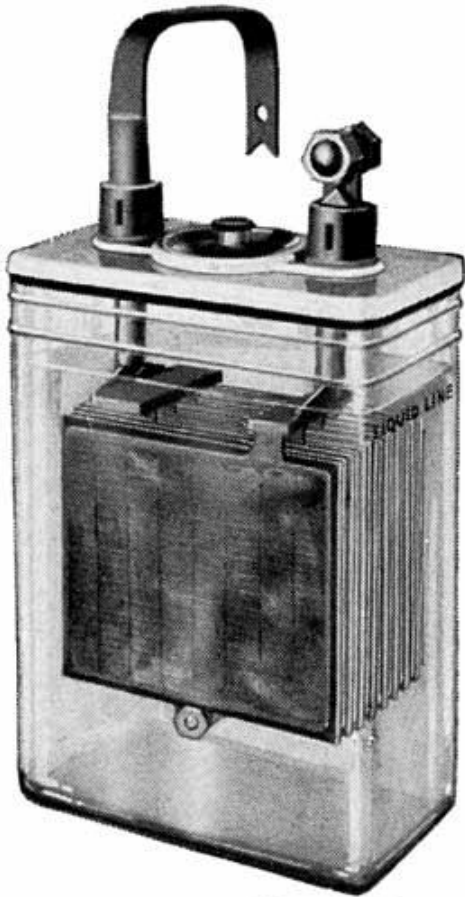

Fig 328. Willard Farm Lighting Cell

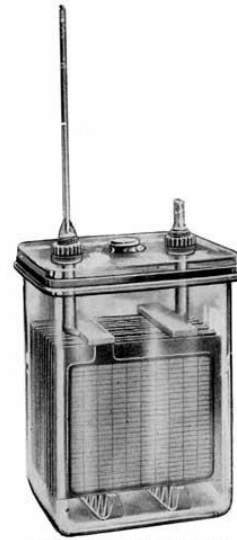

Fig. 296. Exide Farm Lighting Cell with Sealed Glass Jar



Fig. 327. Westinghouse Farm Lighting Cell

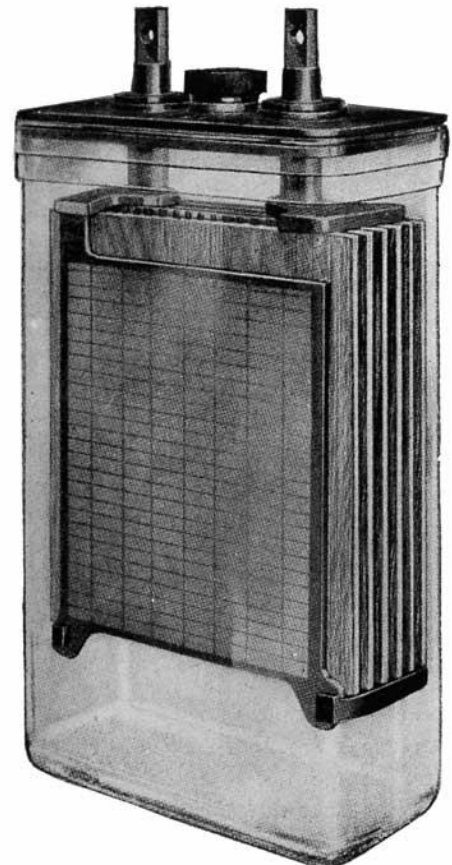

Fig. 295. Prest-O-Lite Farm Lighting Cell, with Lead-Antimony Cover

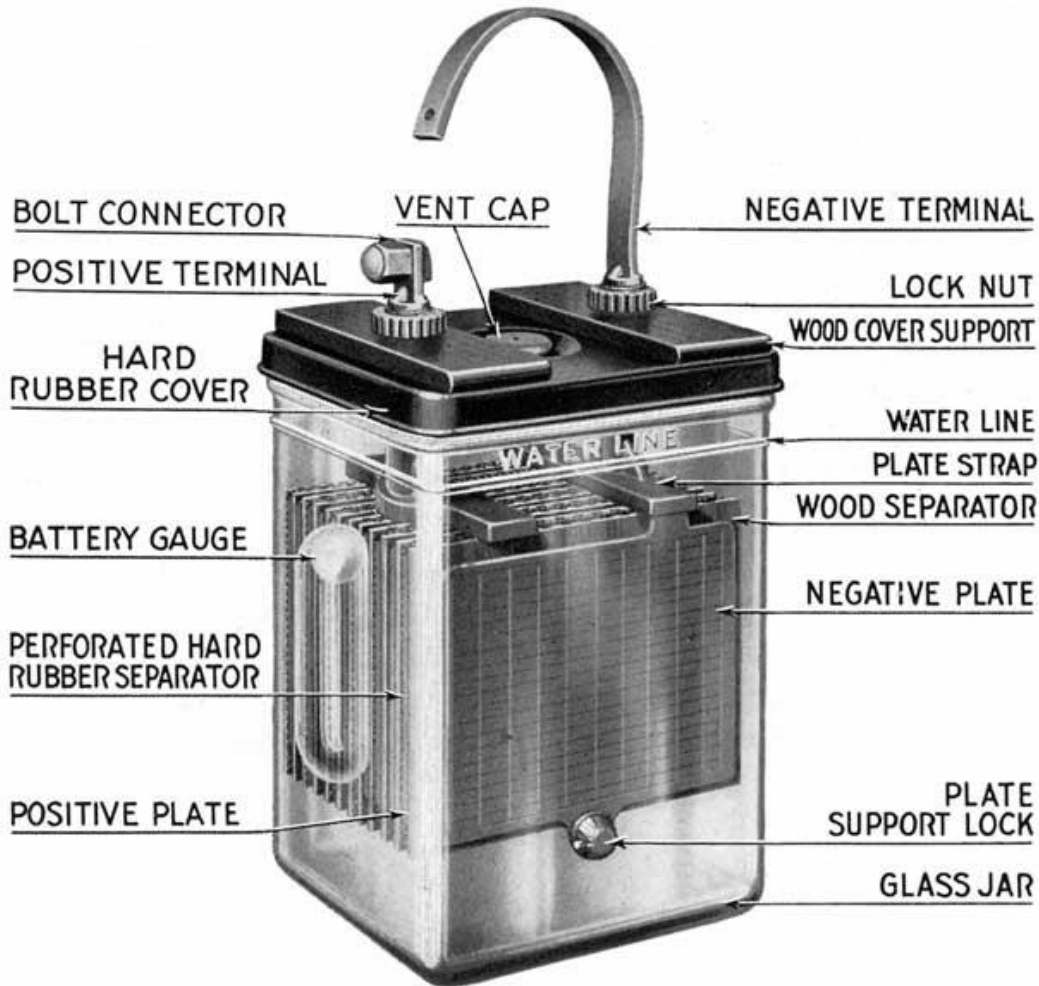

Fig. 294. Exide "Delco Light" Farm Lighting Cell with Hard Rubber Cover

Each battery in a farm array had multiple cells there were usually 16 of these batteries connected together in the array to form the larger battery. The power requirements ultimately determined the number of plates per battery and the total numbers of individual batteries. The rule of thumb was that the entire system would require recharging no more than twice a week.

Farm systems could be wired in parallel or in series, or even both. Parallel connections could be used to achieve the amperage needed, and the rest of the system could be series. Systems like this was more common than we might like to think. Remember, at the start of WWII, only 30% of rural America was electrified. This is why advertising campaigns such as Reddy Kilowatt and the REA were so necessary to provide electrical service in rural areas.

Although many companies supplied Farm and Home Battery systems, the battery jars most often used for such systems are the Delco Light and/or EXIDE rectangular jars, with dimensions of 6 – 8" x 7 – 9" x 10 – 12" tall, similar to those pictured above. Although Delco Light and Exide were the most common, Gould, Grant, Willard, Westinghouse, Prest-O-Lite, and a few others also provided Farm and Home systems.

The following battery jars are typical of those used in Farm /Home battery systems.



DELCO ↑



EXIDE ↑

GRANT ↓



GOULD ↓

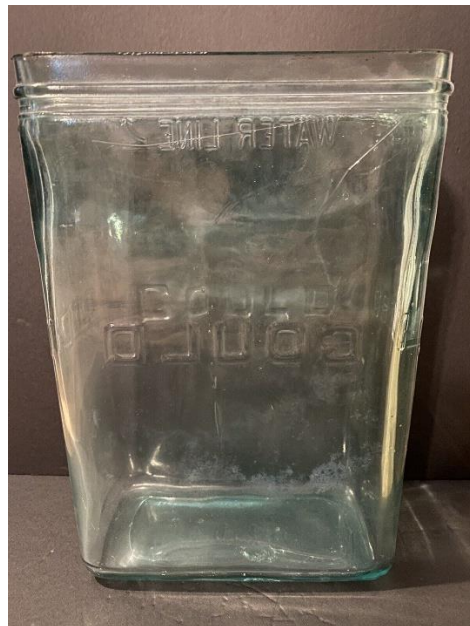



UNIVERSAL ↑

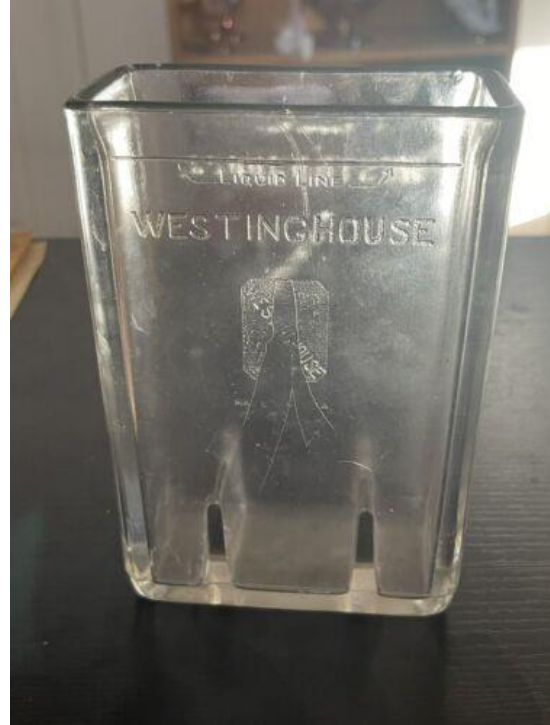

WESTINGHOUSE ↑

OLD IRONSIDES ↓



12 MEDICAL BATTERIES

“Medical Batteries is a broad term used used to describe a self contained apparatus, including a battery , etc., used for medical treatment, including electro therapy, shock therapy etc. It can be a little confusing as we tend to think of a battery as power source, which battery jars were. Where Medical devices are concerned, the entire device is called a battery, not only the power source. As far as I know Medical Batteries are the only field to so classify the entire aparatus as a Battery.

In this volume we will discuss Medical Batteries, their manufacturers, etc. Pictures of any battery jars used in Medical batteries and included in both Volumes, I and II. The discussion of Battery jars is confined to Volume II.

There are many references in the literature of reputable physicians using electro therapy with good results. All such use was closely monitored long term, and all results documented. Beard and Rockwell (32) discuss the benefits of such therapy. The Galvo Faradic Manufacturing Co of New York was formed in 1870 for the sole purpose of manufacturing Electro Medical Instruments. It is believed they were then first to do so, however it is reported but un-verified That the Chloride of Silver Co. successfully treated pain with electro-therapy during the Civil War. By the end of the century, many other companies were offereing such equipment.

Anna Wexler traces the use of medical batteries in the United States in “The Medical Battery in the United States (1870-1920): Electrotherapy at Home and in the Clinic.” An observation of Ms. Wexler is that although many companies were reputable and supplied electro machines to Doctors for clinical use, the market for home use medical batteries was so great that they all offerered a lower end Family Battery in order to reap some of the profits that were to be made from such sales. A copy of Ms. Wexler’s paper is included in Appendix

In 1892, Rockwell, lecturing at the American Electrotherapeutic Association addressed the threats to the credibility of the field. He was primarily concerned with two things. 1. Was the fact that anyone could buy a medical battery of some sort, for the market was flooded with machines of the most inexpensive and worthless construction. The second was close to the first and was the fact that medical batteries could be sold to the general public. To Rockwell, the public’s use of the medical battery undermined the use of electricity as a serious and scientific medical technique that required years of training and expertise.

Unfortunately not all physicians were as ethical as Beard and Rockwell. In addition, the way the FDA rules on medical ethics were written at the time, electro therapy devices did not fall under their jurisdiction. The rules stated that everything in a medical device, etc., had to be stated and that instructions had to be fully described. Since this was done, the electro therapy devices were able to be sold directly to the consumer with no supervision or control. Manufacturers were able to downsize these divices to a single wet cell battery and fit it all in nice wooden box about 8 inches on a side. A multitude of suppliers manufactured and sold them through newspaper and magazine ads. Montgomery Ward and Sears Robuck catalogs in the late 1800’s sold them.

These low end units were exactly that. Something in a box in an attempt to reap some of the profits of what was a huge market at the time.

There were many reputable manufacturers of medical batteries in the last quarter of the 18th Century. In the mid 1880s, *Practical Electro Therapeutics* and *Clinical Therapeutics* reported that the best American Medical Batteries for Clinical use were manufactured by Flemming, Waite & Bartlett, Galvano Faradic Co., Kidder, Stammers and McIntosh. This does not imply there were not other reputable manufacturers. These are ones that were singled out in Medical journals.

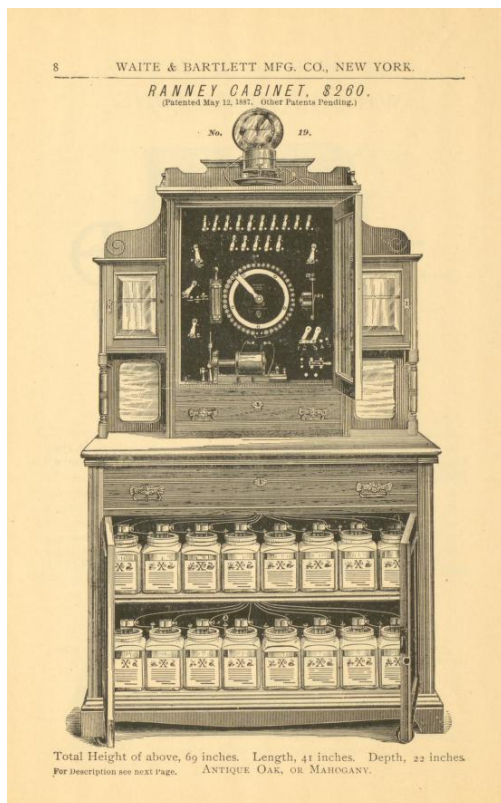

The Ranney Cabinet **12.1**, is one of several electrotherapy devices sold by Waite and Bartlett for use in physicians offices. Note the array of battery jars in the base.

←12.1

On the other end of the spectrum, medical batteries were sold in small self contained units for home use. They were usually contained in, well constructed, wooden boxes and were 1/3 to 1/2 a cubic foot in size. As you will see in the manufacturer's catalogs, many companies sold these self contained electro therapy units, including the ones named above.

The home market was so great that everyone wanted to be part of it. Wexler points out that the catalogs of every major manufacturer of electro medical devices had at least one battery for families. It was almost always the only item that did not target physicians. She points out that the 1895 catalog for Waite & Bartlett offered six faradic medical batteries for physicians and two ten dollar medical batteries – the cheapest in the catalog.

These low end medical batteries were usually called “Family Batteries” and all manufacturers offered them. The Edison LaLande Medical Catalog (circa 1895) offers a “Family” battery for 10 dollars.

The ease with which medical batteries could be obtained led to the mis-use of the machines. Mail Order catalogs such as Rears Roebuck and Montgomery Wards were vary popular shopping

sources at the time particularly for those living in rural areas. For many years both of those catalog supply houses offered a choice of various medical batteries.

MEDICAL BATTERIES

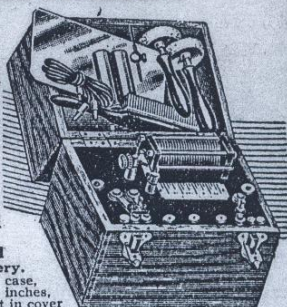
Medical Batteries are in extensive use for the relief of certain diseases and disorders. Their advocates are enthusiastic over the possibilities for relief resulting from the proper use of these machines. We advise consultation with a physician before placing an order, so that the purchaser may be sure to order the particular machine best suited to the purpose for which it is to be used. We guarantee these appliances to be high grade in every respect.

Triple Cell Medical Battery.
Polished oak case, about 9 $\frac{3}{4}$ x7 $\frac{3}{4}$ x8 $\frac{1}{4}$ inches. Three dry cells, Faradic coil, 1 $\frac{1}{4}$ inches in diameter. Circular carbon rheostat regulates current. Four-point switch permits one cell, two cells or three cells to be used at a time. Wheel rheotome for interrupted current, adjustable for slow or rapid interruptions. Metal parts all nickel plated. One pair conducting cords with tips, pair insulating wooden handles, pair nickel plated metal handles, pair sponge electrodes, one nickel plated foot plate, hair brush and an instruction pamphlet included. Otherwise same as 6L9105. Shipping wt., 20 lbs.
6L9110 $\frac{1}{4}$ —Complete with accessories and three dry cells. **\$13.55**

Double Cell Medical Battery.
Polished oak case, about 8 $\frac{3}{4}$ x6 $\frac{1}{2}$ x8 inches, with compartment in cover for accessories and compartment in base for two dry cells. Faradic coil, 1 $\frac{1}{4}$ inches in diameter, with locknut, spring vibrator and adjustable ball attachment for slow vibration. Intensity of current regulated by withdrawing shield. Three-point switch. Pole changer for changing the polarity or direction of the current. Metal parts all nickel plated. One pair conducting cords with tips, pair insulating wooden handles, pair nickel plated metal handles, pair sponge electrodes, nickel plated foot plate, hair brush and instruction pamphlet included. Shipping wt., 13 lbs.
6L9105—Complete with accessories and two dry cells. **\$9.15**
For extra batteries see 6L8635 on page 813.

Single Cell Medical Battery.

Polished oak case, about 10x6 $\frac{1}{4}$ x5 inches, opening top and bottom. Lower compartment for dry cell and battery mechanism, upper compartment for accessories. Faradic coil, 1 $\frac{1}{4}$ inch in diameter, with locking device and spring vibrator. Intensity of current regulated from mild to strong by withdrawing shield from core of coil. Metal parts nickel plated. One pair conducting cords with tips, one pair insulating wooden handles, pair nickel plated metal handles, pair sponge electrodes, nickel plated foot plate and an instruction pamphlet included. Shipping weight, 7 $\frac{3}{4}$ pounds.
6L9100—Complete with accessories and one dry cell. **\$5.80**

← 12.2 is a partial page from a Sears catalog of 1923. The unit is not identified, but it was offered in single, double and triple cell units.

Portable Electro-Medical Batteries.

These magnetic instruments are of undoubted value as the instruments through whose agency physicians effected almost miraculous cures. Our most learned doctors and physicians acknowledge their efficiency in even the worst cases of paralysis, rheumatism, neuralgia, and in fact, all nervous diseases. These machines may be used by all invalids with perfect safety. When doctors fail to effect a cure with drugs and medicines, and electricity is resorted to in the last stage of disease, even then, under such immense disadvantages, electricity often cures.

1.35
ow-
ng).
han
han

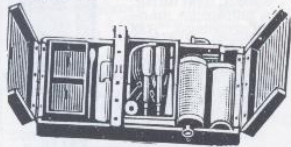

24175 Gaiffe's Battery, three currents, with silk covered conducting cords, two insulated handles, one metallic brush, one olive shaped exciter, one spherical exciter and one vial of bisulphate of mercury. In polished mahogany case, 7 $\frac{1}{4}$ x4x1 $\frac{1}{4}$ in. Complete, with full directions. Weight, 1 $\frac{1}{4}$ lbs. \$7.75
24176 Gaiffe's Battery, with same size coil as in preceding, producing two currents instead of three. Mounted in single cover mahogany case, 6 $\frac{1}{2}$ x4x1 $\frac{1}{4}$ inches, containing two insulated handles and one vial bisulphate of mercury. Weight, 1 pound. Each.....\$6.25

.40
4.25
.50
5.00
.80
6.00



24177 The Crown Family Battery. The merits of this battery will be easily appreciated as possessing neatness of design and simplicity of operating. A pleasant and uniform electric current, both mild and powerful. Three different and distinct currents are produced—the primary, secondary, and both combined in intensity. Mounted in polished cherry case with nickel handles. Size, 6x5 $\frac{1}{4}$ x5 $\frac{1}{4}$ inches, with full directions for using. Highly recommended. Weight, 2 $\frac{3}{4}$ lbs. Price, complete.....\$3.50

.60
6.25
.75
7.50
.85
8.50



24178 Alpha Faradic Family Medical Battery, constructed upon improved scientific principles and designed for private or professional use. Full description of apparatus, directions for operating and directions for making solution furnished with each instrument. Weight, 3 $\frac{1}{4}$ lbs. Each.....\$5.00

DS.
ustic
ly of
self-
screw
tele-
line
teat,
work-
phone
ones,
feet
s and
s the
order
\$5.00
o. 18,
ound
\$0.31

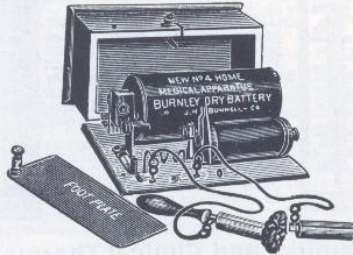

24179 The New Home Electro-Medical Apparatus, with dry battery. This battery is the most convenient and reliable of any hundreds of forms ever introduced. It is reliable, because with its dry battery so much less care is necessary to avoid getting it out of order than is required with any other known form. The entire absence of acids, liquors or salts will be appreciated by any one who has ever had occasion to use a medical battery. The appliance furnished with the apparatus consists of foot-plate, sponge, cords and handles (electrodes). The electrode having a wooden handle is used as a sponge-holder when required. The size of the apparatus is 3 $\frac{1}{4}$ x5x8 $\frac{1}{4}$ inches. Weight, 4 pounds.
Price, complete.... \$7.00 Extra battery, per cell \$0.75
Extra Sponge Holder .50 Extra Handles, pair. .75
Extra Metallic Hair Brush, electrode..... 1.25
Extra Cords, 4 feet, per pair..... .50

1
1



24180 The Genuine Smith & Shaw Portable Pocket Battery, Powerful current. The most practicable and thorough pocket battery made. Cells cannot spill contents.
Price, with two cells (weight, 1 $\frac{1}{4}$ lb.)... \$8.50
Price, with three cells (weight, 2 lbs.... \$10.00

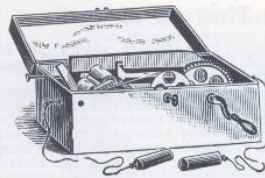

Magnetic Electro Battery.

24182 Davis & Kidder's Genuine Magneto-Electric Machines
Price, each, \$7.25
Weigh, 6 $\frac{1}{4}$ lbs.

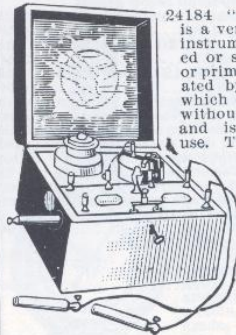

24184 "Family" Battery. This is a very effective and portable instrument, produces the induced or secondary, and the direct or primary current, and is operated by an open battery which can be used for months without changing the solution and is constantly ready for use. The power may be increased by gradually withdrawing the tube from the helix. In polished black walnut case with cords and handles; weight, 8 lbs. Each..... \$10.00

Medical Battery Parts.

Order No. 24185 and be sure to specify what Battery the parts are for.

	Each.
Zincs for the Crown Family Battery.....	\$0.20
Carbons for same.....	.25
Glass Jars for same.....	.25
Tops complete for same, zinc and carbon attached.....	.65
Zincs for the Alpha Battery.....	.25
Carbons for same.....	.25
Glass Jars for same.....	.25
Zinc for Family Battery. Per pair.....	.50
Postage on pair zincs.....	.18
Platinas for same.....	1.00
Clamps for same.....	.25
Cords for same. Per pair.....	.50
Glass Jars for same.....	.25
Metal Springs for Magnetic Battery.....	.10
Cord belt for same.....	.05
Bisulphate Mercury for use with batteries Nos. 24175, 24176 and 24180 per ounce.....	.10
Price, per $\frac{1}{4}$ lb. bottle.....	.75
Price, per 1 lb. bottle.....	1.25
Bichromate Potassium for use with batteries, Nos. 24177 and 24178. Per lb.....	.35

Medical Induction Coil, Without Battery.

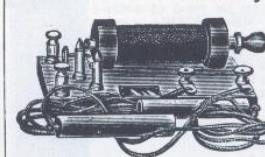

24186 Induction Coil, mounted on neat wooden stand with pair of hand electrodes and sponge holder of best quality. Can be operated with any acid battery. Price, without battery..... \$3.50

24187 Same as above, complete with dry battery cell, ready for use. Weight, 3 $\frac{1}{2}$ pounds. 4.00

Electric Motors.



The Porter Electric Motor, a practical machine for a little money. An entirely novel principle underlies the construction both electrically and mechanically, insuring simplicity, low cost, reduced size, diminished weight, higher speed and wonderful economy in power required to operate them.
24190 The No. 1 Motor, although a very small one in size, is highly efficient. With one

cell of acid battery it will operate a small dental lathe, a fan, a revolving window stand, an egg beater, a music-box, etc. It is no toy. Its electrical efficiency is about $\frac{1}{2}$ horse power, or from 35 to 40 watts on a continuous run. No better motor can be furnished to meet the wishes of young students engaged in the study of experimental physics. Its efficiency will surprise the user. Weight, 1 $\frac{3}{4}$ pounds. Price, each..... \$2.90
24191 The No. 2 Motor, same construction as above, but larger size, weighing 3 pounds and capacity of $\frac{1}{6}$ horse power. Price..... 4.75

←12.3 is a page from a Montgomery Ward Catalog circa 1895.

SEARS, ROEBUCK & CO.



No. 6352. The "Capital" Battery, imitation mahogany case made of cherry and well finished with rounded corners, handle and catch, height 7¼ inches, width 6½x5¼. One of the principal features of this battery is that it uses a Mescro dry cell, which will last from four to nine months, depending largely on how much it is used. It develops a very strong current, is well made throughout, with parts nickel plated and is one of the best batteries on the market for the price; weighs a little less than 5 pounds. New cells of battery can be furnished at

10 cents each. Price complete.....\$4.50
 No. 6353. The Gem Electro Medical Battery. This battery, like the one preceding, uses a dry cell, but the entire apparatus is made in a much more compact form and has a very fine polished oak case which is better proportioned than the one represented by the cut and has a nice carrying handle. The size is



4x1¼x7¼ inches and weighs 5½ pounds. The great advantage to be derived from these batteries is a strong and even current combined with the entire absence of acids of any kind, which are liable to be spilled and injure clothing, furniture, etc. This instrument is furnished complete with cords and handles, one foot plate and two sponge electrodes with wood handles. Price complete.....\$5.75
 Extra battery, per cell..... 70



No. 6384. The "Climax" Faradic Battery. This battery uses a regular zinc and carbon cell of liquid battery, which can be removed from time to time at a very small expense. In other respects it is practically the same as the Capital battery; full instructions accompany each one. Price, complete.....\$4.00

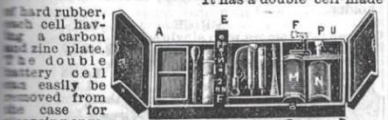

No. 6355. GaiFFE's Battery. The electric current in this instrument is produced with a bisulphate of mercury battery. It has a double cell made of hard rubber, each cell having a carbon and zinc plate. The double battery cell can easily be removed from the case for recharging or recharging. The currents produced by these batteries are as follows:

1. Primary current.
 2. Secondary current.
 3. The current of the first two combined in density.
 4. Shocks slow or fast according to the use of the contact breaker or lever.
- This is the celebrated GaiFFE system for physicians and family use. It is very compact, is all enclosed in a polished mahogany case 4x1¼x7¼ inches, and weighs 1 lb. Complete with full instructions. Each...\$6.50
 No. 6356. GaiFFE's Battery with same sized coil as in the preceding, but produces two currents only instead of three, is mounted in single cover, polished mahogany case, size 4x1¼x8½ inches, with two insulated handles and one vial bisulphate of mercury for recharging the battery. Each.....\$5.40

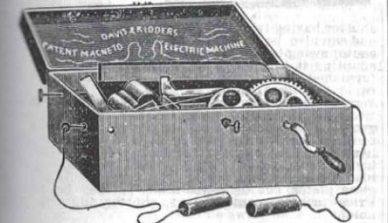

No. 6357. Magneto Electric Battery. This battery is of the celebrated Davis & Kidder type; is operated without the use of chemicals or batteries of any kind. The electric current is produced by the revolving of steel electro magnets by turning a handle from the outside of the case.

←12.4 is an excerpt from a page of a Sears catalog circa 1897.

Taken together, 12.2 through 12.4 show the ease with which medical batteries were available to the consuming public. They also show the years over which they were available. The three, together, cover a period of 28 years, and if we had pages from adjacent years, we're likely looking at a period of at least 30 years.

The following medical batteries were available through mail order catalog sales from Montgomery Ward in the early 1900s

- CROWN Family Battery
- ALPHA Faradic Family Medical Battery
- NEW HOME Electro-Medical Apparatus by Bunnell
- Davis & Kidder Genuine Magneto Electric Machine
- The LITTLE WONDER Electro Magnetic Battery
- No Name LITTLE WONDER Electro Magnetic Machine

Sears & Roebuck offer single, double and triple cell medical batteries (No Name given). In addition, Sears offered:

- The CAPITAL Battery
- The GEM Electro Medical Battery
- The CLIMAX Faradic Battery
- GAIFFE's BATTERY, two & three current models
- DAVIS & KIDDER Magneto Electric Battery

Like most subjects, Electro medical devices covered a broad spectrum, from Physicians units to home units and beyond. People were intrigued and fascinated to the extent that it became Carnival in nature. I can say that quite literally as, by circa 1913 medical batteries had become an arcade attraction. Below we see two such popular attractions. Just insert a coin and hold the handles to improve your health. The first is the **Mills** electric shock machine, **12.5**. The **Acme** electro shock machine is shown in **12.6**. These units were obviously on the other end of the spectrum from Medical Batteries



←12.5



12.6→

As farsical as the Mills and Acme units may seem, the spectrum continues on even further. The 1920s saw the introduction of the Electronic Radio Biola, manufactured by The Biola Mfg. Co of Trenton, N.J. **12.7** ↓ **12.8**↓





12.9→



↑12.10

Pictures, **12.7** through **12.10** show the Electronic Radio Biola. The battery jar is 4 ½" diameter x 5 ¼" tall, in a mahogany case. The only embossing is on the top : **AUTOMATIC / (arc) ELECTRONIC RADIO BIOLA (arc) PATENT PENDING / THE BIOLA MFG. CO. INC. / NORFOLK, VIRGINIA.** There are two electrical terminals on the top, labeled OUTLET (-) and INLET (+), which, in turn are connected to electrodes. Directions called for attaching one electrode to a radiator, filling the jar with water and replacing the top, which immerses the electrodes in the water. Attach the other electrode to yourself and relax, while all manner of diseases fled your body to be trapped in the water and discarded. **Courtesy of Walt Baumgardt.**



The satire in the caricature of ←12.11 captures the frenzy of the movement at the time.

12.1 GALVANIC VS. FARADIC CURRENTS

For those of you that want to pursue this further, you should be aware that there were two distinctly different Direct Currents (DC) available, by changing the settings on some of the machines. The different currents are Galvanic and Faradic, and each can be modified further, as you will see.

Galvanic Current uses a long and continuous current flow, effective creating an electric field over the area This is shown schematically in 12.1.1↓,

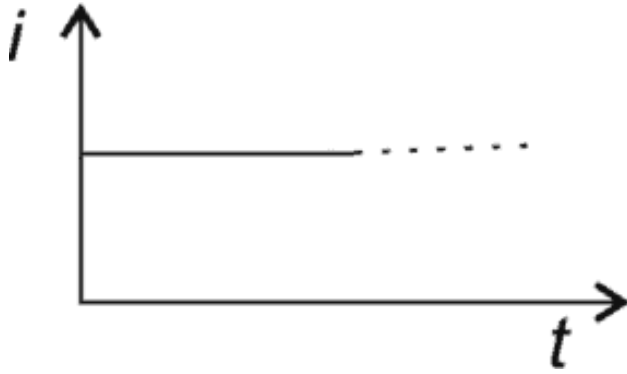

Galvanic Current can be interrupted as pictured in the following schematics; **12.1.2** through **12.1.4** which show Rectangular, Trapezoidal and Saw Tooth Patterns. Typical current application is in the range of 100 ms or greater. The frequency is adjustable.

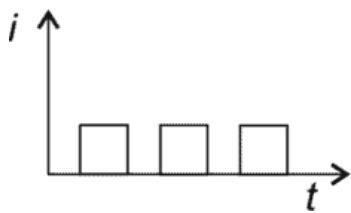

12.1.2↑

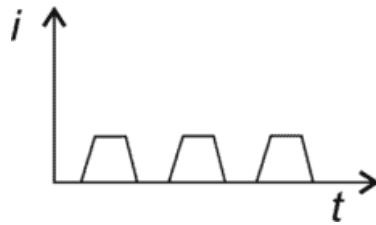

12.1.3↑



12.1.4↑

Faradic Current is characterized by pulses with defined shape and intensity as seen in **12.1.5**↓.

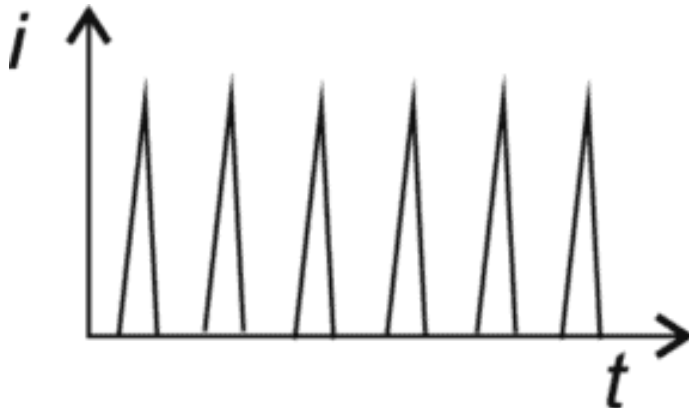

Unlike the 100+ ms duration of Galvanic Current, the duration of a Faradic Pulse is 0.1 – 1 ms. Faradic current rises rapidly but is not instantaneous, falling back to zero immediately after reaching its maximum.

Faradic Current can be surged, creating a pattern similar to that of **12.1.6**↓.

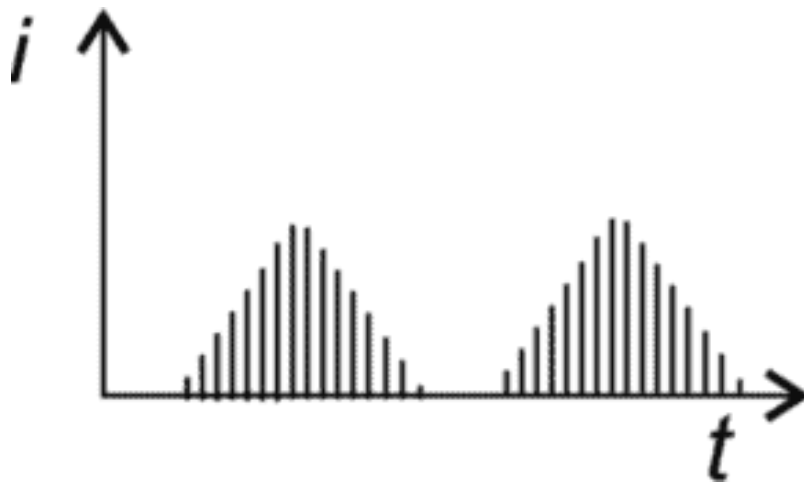

Surges can be adjusted , as can the frequency.

It is difficult to know how many medical batteries of the day differentiated Galvanic and Faradic Currents. The name Galvanic Faradic Mfg. Co. certainly implies they were aware of the differences. I'm certain the higher end machines used in Physician's offices and Clinics were fully adjustable for either Galvanic or Faradic currents. It is doubtful if the low end family batteries, meant for home use had that capability.

Electro Therapy was popular at the time and I believe many doctors were truly using it to better mankind, but the carnival atmosphere led to Quacks and Charlatans entering the field. Many of the benefits attributed to electro-therapy truly stretched the imagination.

I'm not saying that the medical batteries would have ever found a place in medicine, but the charlatans didn't help their cause. It is rumored that the dollars of the Pharmaceutical companies helped to get the FDA to rule against electro-therapy, because there was more money to be made in pharmaceuticals. It is food for thought, as, Canada and Europe allow electro-therapy with few restrictions.

Today electro-therapy is making a comeback, and those who practice it admit that they are still paying for past mistakes. Having personally been treated, successfully, with electro therapy, I personally believe, to some extent, it is a case of the baby being thrown out with the bath water.

I include in the pages that follow, a brief history of the companies involved with Medical Batteries, at the time, as well as any battery jars that they may have used. This is not meant to be

all inclusive, but rather those whose names kept coming up in my research of the topic, and/or medical batteries I have seen.

12.2 WHITALL TATUM & F.G. OTTO & SONS

You all know Whitall Tatum. It was founded in Millville, NJ by James Lee as the Millville Glass Works in 1806. John Whitall became a partner in 1838, and in 1845, after I.F. Whitall joined the company, it became Whitall, Brother & Co. When Edward Whitall joined the firm in 1857 the name was changed to Whitall Tatum & Company. In 1901 it became Whitall Tatum Company. Through the years they manufactured bottles, jars, laboratory glassware, fruit jars, paper weights, museum jars, insulators and many other items. Armstrong Cork purchased the company in 1938. In 1999, the plant celebrated 193 years of continuous glass production. I have combined Whitall Tatum with F.G. Otto & Sons, as the two companies seem to be intertwined.



An example of a medical battery for home use is pictured, left, (12.2.1); “The Florence” by Whitall Tatum and F.G. Otto & Sons. The Florence, is typical of the many medical batteries manufactured for home use. It does have a certain air of mystery about it; as I tried to determine who manufactured it. The mahogany case is embossed “WHITALL TATUM & CO.”, along with the Patent date of “Aug. 18, 1885”, (12 – 4), while the battery jar is embossed “F.G. OTTO & SONS / NEW YORK”. Courtesy of Walt Baumgardt

←12.2.1

I was leaning toward Whitall Tatum as the battery jar manufacturer, as their catalogs of 1879 and 1880 showed battery jars in their product line. The problem was: where did F.G. Otto fit into the picture.

Ferdinand G. Otto arrived from Germany in the mid 1800’s. He initially worked for George Tiemann & Co., a manufacturer of surgical instruments since 1826, before going into business for himself, partnering with Augustus Koehler (from 1853-1860) and John Reynders (from 1860 – 1875) before partnering with his sons, Albert and Gustav starting in 1875. We know that F.G. Otto supplied surgical instruments during the Civil War, and that continued with F.G. Otto & Sons. They were based in New York City until the 1880s, when they expanded by moving to Jersey City. In the 1890s they started to manufacture Disc Music Boxes. Ferdinand died in 1898 but the It was not until the advertisement for the “Mystic”. (12.2.2, below), was found that we realized, that at some point F.G. Otto & SONS had expanded their role in the medical field to include medical batteries. We now knew that Whitall Tatum had likely manufactured the Battery jars for F.G. OTTO & Sons, who manufactured and sold the “Florence”

and The “Mystic”. They also offered the Manhattan, a two cell medical battery. Literature reports a Barclay model, But I could find no information on it.

12.2.2→



12.2.3↑

Whitall Tatum’s involvement with Medical Batteries seems to be more involved than once thought. It seemed, early on that they merely manufactured the battery jars for F.G. Otto & Sons. In section 11.4 we find that they were a rep for Voltamp medical batteries. I could never find anything to explain why the Whitall Tatum name is imprinted on the Mahogany boxes housing the medical batteries. None of the articles I’ve found, that traces the history of Whitall Tatum, suggests that they were never anything more than a glass house. I hope that at some point Whitall Tatum’s involvement, will be known.



12.2.4↑



12.2.5↑

The Battery jars, above (12.2.4 and 12.2.5) are from The Florence. 12.2.4 is the plain jar, embossed (arc) **F.G. Otto & Sons / NEW YORK**. 12.2.5 is an identical jar with the cap for electrical connections. **These jars are courtesy of Walt Baumgardt.**

Note: the picture of “The MYSTIC” (12.2.2) appears to show a battery jar with a round top. This fits well with the battery jar found by Don Briel, 12.2.6, which is embossed (arc) **F.G. OTTO & SONS / JERSEY CITY**. It has a 3” square bottom with a 2” diameter round top. It is 4 ¼” tall. I suspect this slightly smaller battery jar, likely manufactured by Whitall Tatum was used in the Mystic. **Courtesy of Don Briel.**



←12.2.6

These smaller batteries were largely used in portable devices such as medical devices. The technical name for them is the Poggendorf (commonly referred to as the Grenet Cell (12.2.7). As you can see the term Grenet or Poggendorf cell refers to what I called, earlier, the Specialty battery smaller and generally unusually shaped. We know they were manufactured by Whitall Tatum and perhaps Willard. Likely, other companies manufactured them as well. As they are identified they will be added to the list. They were used by F.G. Otto & Son, Waite and Bartlett and others in their medical devices.



←12.2.7. Grenet Cell

12.2.8↓ is merely embossed with the Gamewell logo. Its dimensions are 4" square x @" tall base, with a @"square x 2" tall neck. It is in the Whitall Tatum design. **Courtesy of Tommy Bolack.**



←12.2.9

The one on the left is embossed H.S. / NEW YORK and is 3.5" square x 2" high with a 2" square x 1.75" tall neck. The other will be discussed below. **Courtesy of Tommy Bolack.**



Based on the similarity to the Whitall Tatum produced battery jars seen above it is likely that they manufactured the jars in 12.2.8 and 12.2.9, although this is not known for sure.

It should be noted that Whitall Tatum had a long history of manufacturing glassware for Medical and Laboratory use.

12.3 LUIS DRESCHER

Luis Drescher offered a Pocket Medical Battery, which will be discussed in Chapter 12.2.

Not much is known about Luis Drescher, other than he was a physician in New York City in the last 19TH Century. We know he was active in using electricity to treat his patients, attested to by the patents granted in his name in the last quarter of the 19TH century.

Among the patents attributed to Luis Drescher are:

<u>Pat. #</u>	<u>Date</u>	<u>Name</u>
• #116,695	July 4, 1871	Galvano-Faradic Machine
• #168,560	Oct. 11, 1875	Magneto-Electric Machine
• 350,621	Oct. 12, 1886	Galvanic Battery Cell
• 352,084	Nov. 2, 1886	Medical Induction Coil
• 369, 505	Sept. 6, 1887	Galvanic Cell
• 525, 491	Sept. 4, 1894	Electric Battery
• 753, 051	Feb. 23, 1904	Mechanical Toy

We also know that he influenced the medical battery jars produced by Whitall Tatum, as his initials with the July 4, 1871 date appear on medical battery jars produced by Whitall Tatum.

It should be noted that Whittall Tatum made a 4" square jar similar to **12.1.4**, with the following embossing: **LD / Patented / July 4th / 1871** on the neck. **This jar is shown in 11.3.1 and 11.3.2.** Courtesy of Walt Baumgardt.

12.3.1→



←**12.3.2** is the rest of the jar shown in **12.3.1**.



The battery jars we see in **12.2.8**, **12.2.9** and **12.3.3** are all very similar to those we've seen previously from Whittall Tatum. Except for the visible embossing, they are all unmarked. Although another company could have manufactured them, we know that Whittall Tatum manufactured this style for F.G. Otto & Sons. So, there is a fair likelihood that Whittall Tatum manufactured these as well.



←12.3.3

Both of these are embossed on the neck, LD / PATENTED / July 4 / 1871. The one on the left is further embossed on the skirt: (arc) F.G. OTTO & SONS / JERSEY CITY, while the one on the right has no further embossing. The dimensions of both are 4" square x 2" tall base with a 2" square x 2" tall neck. **Courtesy of Tommy Bolack.**

12.4 MAGNETO -ELECTRIC MACHINES

Before electricity became available with battery jars, Magneto-Electric Machines were used to treat pain. There is documentation that they were used for pain management during the Civil War. Davis and Kidder patented such a machine in 1854. It had a hand crank which when turned produced an alternating current. The strength of the current depended on the speed at which the crank was turned.

The makers claimed it would relieve pain as well as cure numerous diseases, including cancer, heart disease, gangrene and spinal deformities, to name a few.

You will recall the Tesla is credited with the discovery of Alternating Current using a rotating magnetic field. Apparently, the makers of the magneto-electric machines didn't realize what they had. It was almost 50 years later that Tesla made his discovery.

12.4.1 DAVIS & KIDDER



←12.4.2

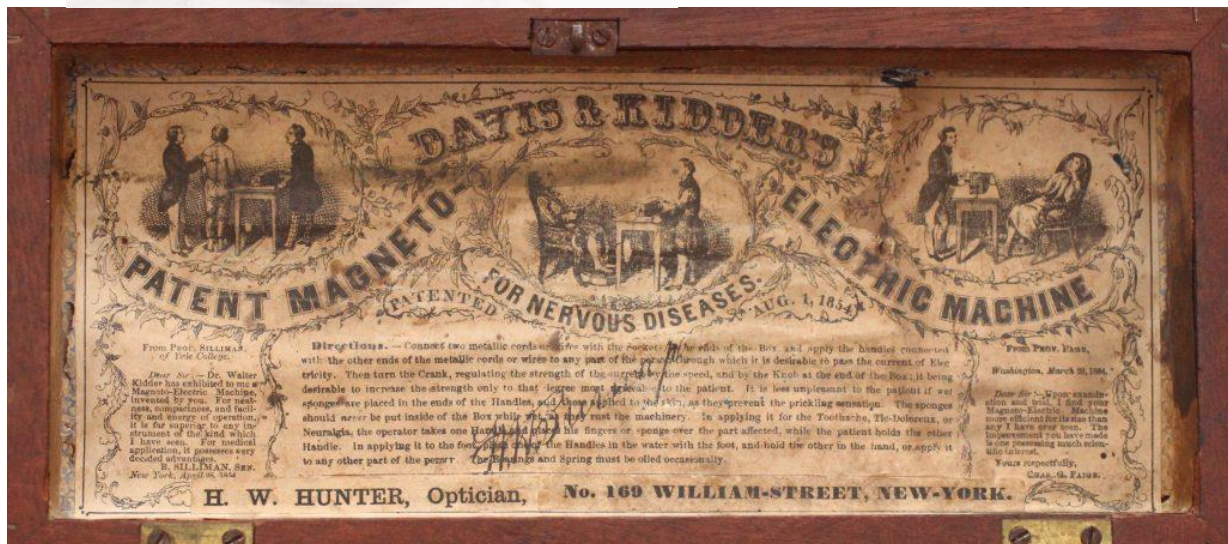

↑ 12.4.2

The Davis & Kidder Magneto – Electric Machine **12.4.1** and **12.4.2**, above, was patented in 1854 and there is documentation (136) of its successful use to manage pain during the Civil War.

Ari Davis, was a skilled craftsman who received two patents in 1854. #10,788 a machine for producing wooden boxes with metal-reinforced corners and # 11415 described a magneto-electric machine. He sold the rights for both, to a physician, Walter Kidder, in Lowell, MA. In a very short time advertisements for DAVIS' (and later DAVIS & KIDDER'S) PATENT MAGNETO-ELECTRIC MACHINE , for NERVOUS DISEASES, were seen. They were manufactured by W. Kidder, whose signature is on all genuine machines. By 1857 the business was in the hands of William Burnap, also from Lowell. By 1865, Burnap was in New York advertising as "Manufacturer of Davis & Kidder's Electric Machine".

12.4.2 James W. Queen

A Magneto Electrical device similar to Davis & Kidder was manufactured by James W, Queen & Co. of Philadelphia and New York. It is shown in **12.5.1**, below. If not for the label in the lid you couldn't tell them apart.

12.4.2.1↓



Mr. Queen started his company in Philadelphia in 1853 as a supplier of optical and philosophical apparatus. In 1859 he associated with Samuel J. Fox. They grew the business, James W. Queen & Co. to the point where it had out-stripped most other firms. In 1873 they published a 160 page catalog of Mathematical Instruments: Materials for Drawing, Surveying and Civil Engineering. They had similar catalogs for their other product lines. By 1888 the firm had grown to the point where they had six different departments: Physical and Chemical, Engineering, Ophthalmic,

Microscopical, Magic Lantern and Photographic. Mr Queen retired in 1873 but the company retained the name, James W. Queen & Co. until 1893 when it became Queen & Co. John Gray reorganized in 1912 as Queen-Gray Co, and when he passed in 1925 to The Gray Instrument Co.

12.5 VOLTAMP

Voltamp has a most interesting history. It was founded by Manes E. Fuld in the 1890s as a manufacturer of toy trains, based in Baltimore, MD. In 1907 they released the first toy train to run on ordinary household alternating current. Until this time all toy trains had been powered by batteries on Direct Current. The Voltamp Electrical Manufacturing Co., organized in 1904 was an outgrowth of the Chloride of Silver Battery Co., also of Baltimore. Around 1922 Fuld sold the Toy train business to Lionel. Voltamp Electrical Manufacturing Co. continued to produce an entire line of medical batteries. Fuld was a man of varied interests, with 8 patents to his name, including:

<u>Pat. #</u>	<u>Date</u>	<u>Title</u>
• 620,027A	Feb. 21, 1899	Induction Coil
• 627,408A	June 20, 1899	Packing Case for Electric Cells
• 627917A	June 27, 1899	Dry Cell
• 837,213A	Nov. 27, 1906	Improvements to Electric Motor
• 840,451A	Jan. 1, 1907	Improvements in construction of commutators
• 1,439,956	Dec, 26, 1922	Dry Cell Battery

All the Voltamp medical batteries used dry cells. They all use dry cell technology, where many earlier models such as those by F.G. Otto & Sons used wet cells.

12.5.1↓ Falcon Battery No. 1



12.5.2 Voltamp No. 1



12.5.3↓ Voltamp Battery No. 2



12.5.4↓ Voltamp Battery No. 3



12.5.5↓ Voltamp Battery No. 4

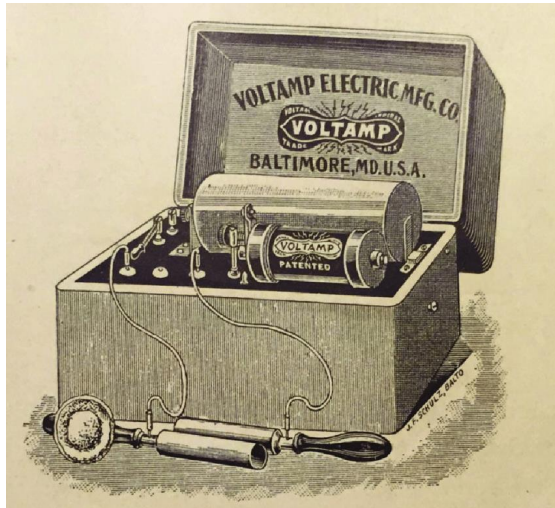

12.5.6↓ Voltamp Battery No. 6



12.5.7↓ Voltamp Battery No. 7



12.5.8↓ Voltamp Battery No. 8

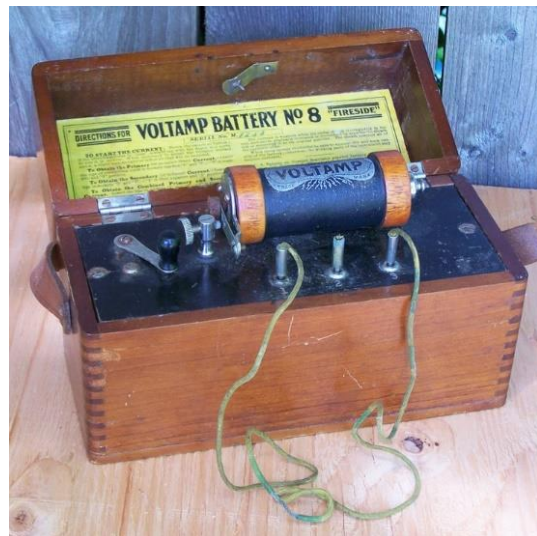

12.5.9↓ Voltamp Battery No. 9



12.5.10↓ Voltamp Battery No. 10



12.5.11↓ Voltamp Battery No. 11



12.5.12↓ Voltamp Battery No. 12



12.5.13↓ Voltamp Battery No. 16



12.5.14↓ Voltamp Battery No. 24



There may have been other Numbers in the Voltamp series, but these are what I could find. I found an unverified reference to the fact that Voltamp Medical Batteries were manufactured by the McKee Surgical Instrument Co. of Washington and New York. It appears that Voltamp sold through other companies or Agents. Several of the batteries showed company names on the paper label in the lid other than or in addition to Voltamp Electric Mfg. Co. These included:

- Chas. Truax, Green & Co., Chicago
- Truax, Green & Co., Chicago
- Feick Brothers, Pittsburg
- Tower Electric Co., ??
- Keystone Electric Co, Philadelphia
- J.A. Schultz Co., ??
- Sibley Mfg. Co., Minnesota
- Montgomery Ward
- D.D. Home Appliance Co.
- Geo. C. Frye Co., Portland, ME
- Whitall Tatum Co.

You will note that Whitall Tatum keeps appearing in various aspects of medical batteries. At first it seemed that they manufactured the battery jars for the batteries. Then their name appeared as stamped on the cases of the medical batteries. Now they show up as an agent for Voltamp Medical Batteries. Yet the several profiles I've found on Whitall Tatum mention none of this. There seems to be more to Whitall Tatum's involvement with medical batteries than we know.

12.6 MCINTOSH GALVANIC & FARADIC BATTERY CO.

McIntosh Galvanic and Faradic Battery Co. of Chicago Illinois was another manufacturer of medical batteries. Dr. L.D. McIntosh founded the McIntosh N.U Supporter Co. about 1870. A man of diverse interests, he entered the medical electric field, incorporating as the "McIntosh Galvanic Belt and Battery Co." The name was changed to the "McIntosh Galvanic and Faradic Battery Co." About 1889 the name was changed again to the "McIntosh Battery and Optical Co." offering microscopes and other optical equipment into the 1890s. Dr. McIntosh died in 1892 and the company was sold about 1897. It was only in business for approximately 25 years and never saw the boom in medical batteries in the early 20TH century. McIntosh also offered an Electric Belt.

ELECTRIC MASSAGE BATTERY



Prepare the face with **Lettuce Cream**. Allow the patient to hold in his hand the metal Electrode attached to the battery. Attach the No. 1 handle and spongio disc to the other pole of the battery, and apply it to the forehead and face according to the tolerance of the patient. The Spongio Disc must be thoroughly wet, as the electricity passes through the moisture, and cannot pass through dry sponge. This application is especially beneficial in treatment of Headache, Neuralgia and Nervous Fatigue. The **Massage Roller** is used in the same manner as the Spongio Disc. Its especial merit is that when the chamomis is well moistened a stronger current may be applied regularly to face and neck.
Send for complete catalogue.

McINTOSH BATTERY AND OPTICAL CO.
39 WEST RANDOLPH STREET, CHICAGO, ILL.

←**12.6.1** shows the McIntosh No. 44 Faradic Battery, while, **12.6.2**→ shows a medical battery, merely labeled, McINTOSH / Galvanic and Faradic Battery Co. /



Chicago, with a patent date of Nov. 29, 1881 (**12.6.3**, below)



← **12.6.3**

12.6.4↓



←**12.6.5**

12.6.6→



12.6.4 through 12.6.6 show additional features of the battery, namely the unique battery jar and electrodes.

12.7 CHLORIDE OF SILVER BATTERY CO.

12.7.1↓



12.7.2↓



The Chloride of Silver Battery Co., of Baltimore Maryland is just one of the companies offering Dry Cells (See Chapter 9). They were certainly one of the first to use dry, rather than wet cells, for power.

12.7.3↓



←12.7.1 through 12.7.2 are medical batteries offered by the Chloride of Silver Battery Co.



12.7.3 is known as The "Lord

Baltimore". I'm not sure, but it appears the "Lord Baltimore" may have used a wet cell battery. Later offerings used dry cells, similar to 12.7.4.↑

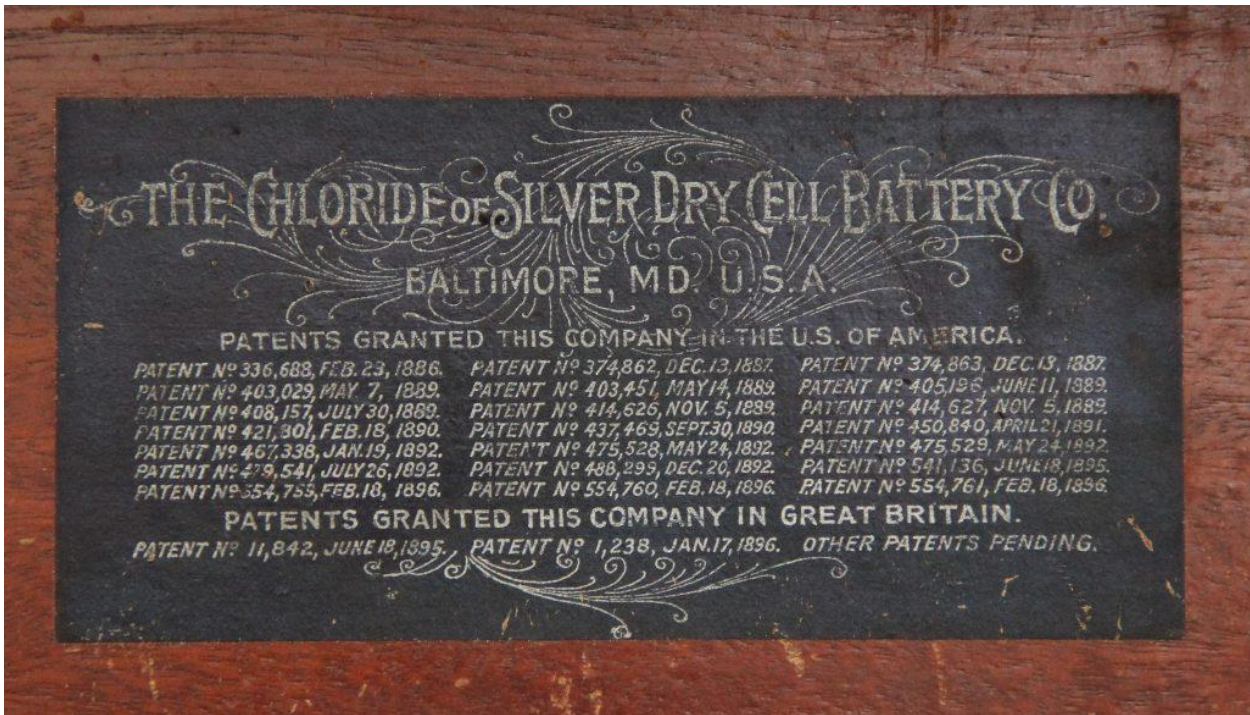

12.7.5↑ lists the patents granted to The Chloride of Silver Dry Cell Battery Co. in both the U.S. and England, as found on the inside cover of a medical battery.

12.8 OTTO FLEMMING

Otto Flemming was a Doctor in Philadelphia in the latter half of the 19th century. Unfortunately all we know about Dr. Flemming is from paper titled “Electricity in Medicine”, by Harrison Allen, M.D. It was delivered at the International Electrical Exhibition, Sept. 30, 1884. They were dealing with Electrical Cautery, and Dr. Harrison describes the battery developed by Dr.s Paul Seilers and Otto Flemming. It employs stationary plates with the electrolyte brought into contact with them by the operator applying pressure upon a treadle. The major advantage being that the current ceases as soon as the operator removes pressure from the treadle, thus giving the operator critical control during a cautery procedure. The battery is covered under patent 320,547 assigned on June 23, 1885, titled “Medical Battery”.



←**12.8.1**, is an Otto Flemming Medical Battery.; perhaps the one described above. Although un-embossed, The number of cells indicate that this was a clinic model and not a home unit.

12.8.2→

12.8.2 is a portable battery designed and manufactured by Otto Fleming. It is very similar to other portables of the time, such as offered by F.G. Otto. Note the Number embossed in the lid is “00”, the first in a line of medical batteries. The battery jar is missing, but based on the size it appears very similar to the jar in the next Flemming battery (**12.8.3 through 12.8.7**).



12.8.3↓



12.8.4



12.8.3 through 12.8.7 are photos of another Otto Flemming medical battery. It is 6" x 6" x 7" tall, and is covered in leather. It is complete with the sponge electrodes and battery jar. The jar is embossed on the front: **O FLG / PHILADA**. A name plate in the lid reads: **THE / FLEMMING BATTERY / designed & perfected by / OTTO FLEMMING, / 1009 Arch Street, / Philadelphia, PA.** Courtesy of Walt Baumgardt.

←12.8.5



12.8.6→





← **12.8.7** is the battery jar from **12.8.3** through **12.8.6**.

12.9 EDISON MEDICAL BATTERIES

Like many other manufacturers of medical batteries Edison, too, offered high end equipment for clinical work and physicians use, but also offered the \$10.00 family battery.

The *Edison Mfg., Co.* was incorporated in 1900, as Edison's personal business. It manufactured and marketed the Edison-LaLande primary battery as well as batteries for telegraph, telephone, phonograph. It also sold X-Ray equipment, medical instruments and electric fans as well as having a motion picture branch. The LaLande (ESB CO.) was an alkaline primary battery developed by Edison from an earlier design by Felix LaLande. It consisted of copper oxide and zinc plates in a solution of potassium hydroxide.

Additional information on Thomas Edison can be found in Chapter 3.

12.9.1↓ is a Galvanic Cabinet for Physicians.



EDISON COMBINATION CAUTERY AND GALVANIC CABINET.

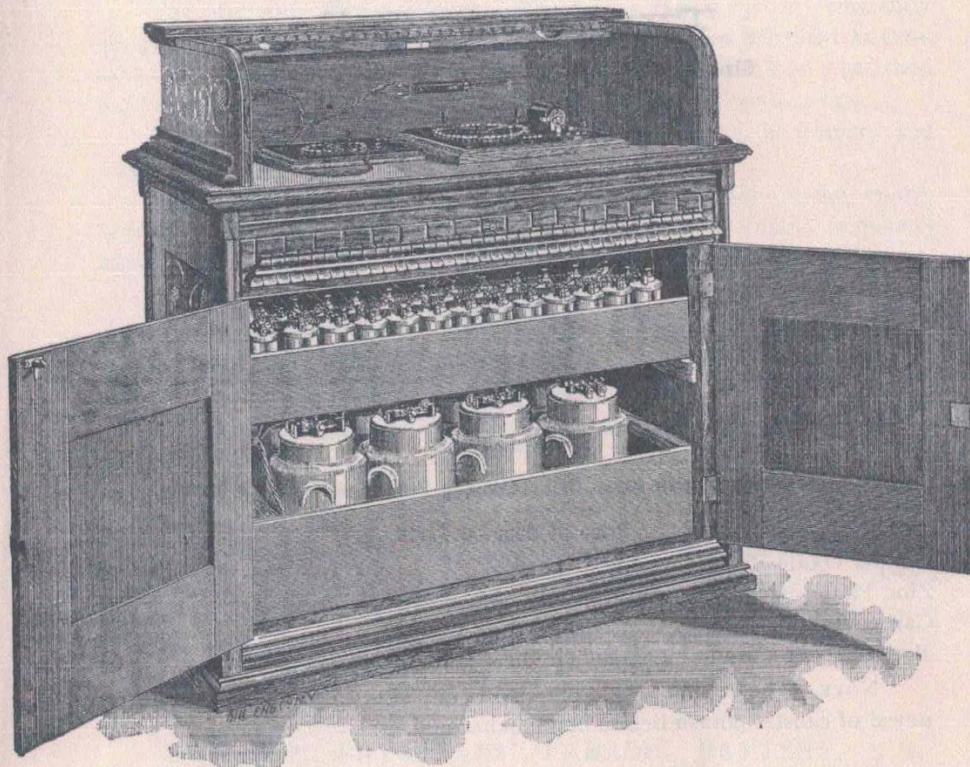

FLOOR SPACE 3 FT. 10 X 2 FT. 2 IN.

This cabinet is similar in design to the galvanic cabinet illustrated on the previous page. The eight Edison-Lalande cautery cells are contained in the lower tray and are connected to a circular rheostat mounted on the top alongside the switchboard which is connected with 50 Edison-Lalande cells for galvanic and faradic work contained in the upper tray.

12.9.2↑ combines a Physicians medical battery with a cautery unit, for clinical use.

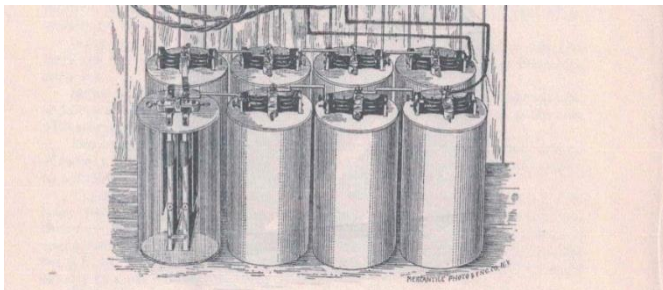

←**12.9.3** shows the battery unit required to power the Cautery unit. The battery unit was 300 amp-hrs.

Faradic Batteries.

The EDISON *Physicians' Faradic Battery* is eminently adapted for the use of the profession, and consists of two EDISON-LALANDE cells connected to a powerful medical induction coil mounted on a polished hard rubber base; the whole outfit enclosed in a polished walnut box.

The coil is so wound that the strength of current in the primary and secondary is perfectly progressive.

The vibrations obtained are of a very pleasing character, being entirely free from uneven pulsations, a cause of considerable trouble frequently experienced.

When battery is not in action it is unnecessary to remove the zincs from solution as in most other Faradic batteries, but simply to turn the switch as there is no waste on open circuit.

The current furnished by the cells is perfectly constant, so that battery can be used for hours without falling off in strength.

The cost of renewal of battery is very low and perfectly easy to accomplish.

The EDISON *Family Faradic Battery* fills a demand for a first class battery at a moderate price. In construction it is similar to the physicians' battery, only that the coil is mounted on a walnut base to match the box, instead of hard rubber, and the cells have porcelain covers.

In both these batteries the cells are perfectly airtight.

EDISON PHYSICIANS' FARADIC BATTERY.

Price Complete, in Polished Walnut Case, together with Sponge Electrodes..... **\$15.00**

The same with interchangeable fast and slow vibrators..... **16.00**

Price of Renewal Parts For Both Cells.

2 Copper Oxide Plates..... \$0 16

2 Zinc Plates..... 16

Can containing 4 sticks Potash.. 16

2 oz. Bottle of Oil sufficient for 2 cells..... 05

Total..... .53

The Copper Oxide Plate and Zinc Plate will stand two charges (one renewal) of caustic potash solution before being exhausted.



Edison also offered two cell physician's (←**12.9.4**) and family batteries (**12.9.5↓**). Generally the family battery was a single cell which could be upgraded to a double or triple cell for additional \$\$.

The entire catalog of Edison-LaLande Medical batteries from the Edison Manufacturing Co. is included in Appendix E.

EDISON FAMILY FARADIC BATTERY.

Price complete, in Polished
Walnut Case, together
with Metal Electrodes ..\$10.00

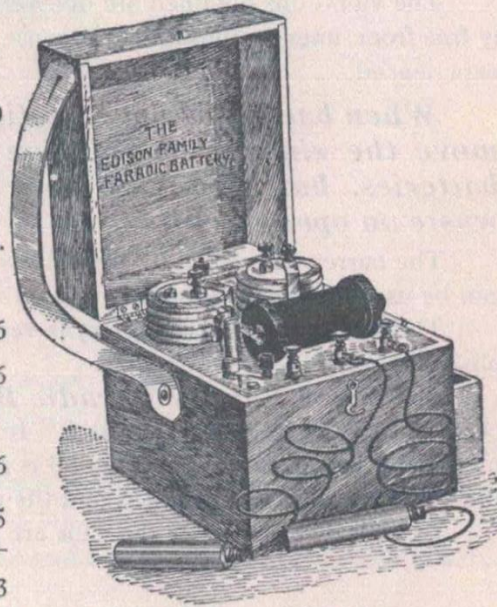

Price of Renewal Parts For Both Cells.

2 Copper Oxide Plates.....	\$0	16
2 Zinc Plates.....		16
Can containing 4 sticks Potash.....		16
2 oz. Bottle of Oil for 2 cells.		05
Total....		53

The copper Oxide Plate and Zinc will stand two charges (one renewal) of caustic potash solution before being exhausted.

Prices of Accessories.

Sponge Electrodes and Handles, per pair.....		\$1.00
Metal Handles.....	“ “	.50
Battery Cords.....	“ “	.50
Slow Vibrators, each.....		1.00

12.9.5↑

12.10 VAN HOUTEN AND TEN BROECK, GALVANO FARADIC MFG. CO.

The Galvano-Faradic Manufacturing Co. was established in New York in 1870 for the express purpose of manufacturing Electro Magnetic Instruments of the highest quality. It offered medical batteries of every size from the 40 Cell Clinic battery to the more normal sized units.

It should be noted that Van Houten and Ten Broeck (VH&TB) are listed as Proprietors for the Galvano Faradic Manufacturing Co. In Volume I, where we look at battery jars themselves, we find that Van Houten and Ten Broeck are listed as Proprietors of several companies.

We know that VH&TB offered battery jars themselves, or through agents, as well as X-Ray units and Static Machines (10.0.2).

The following ad (12.10.1↓) says they were established in 1870, the same year as the Galvano Faradic Manufacturing Co. It also implies that they are the sole makers of various brands of electrical equipment and medical batteries. That is about all I could find on the company.

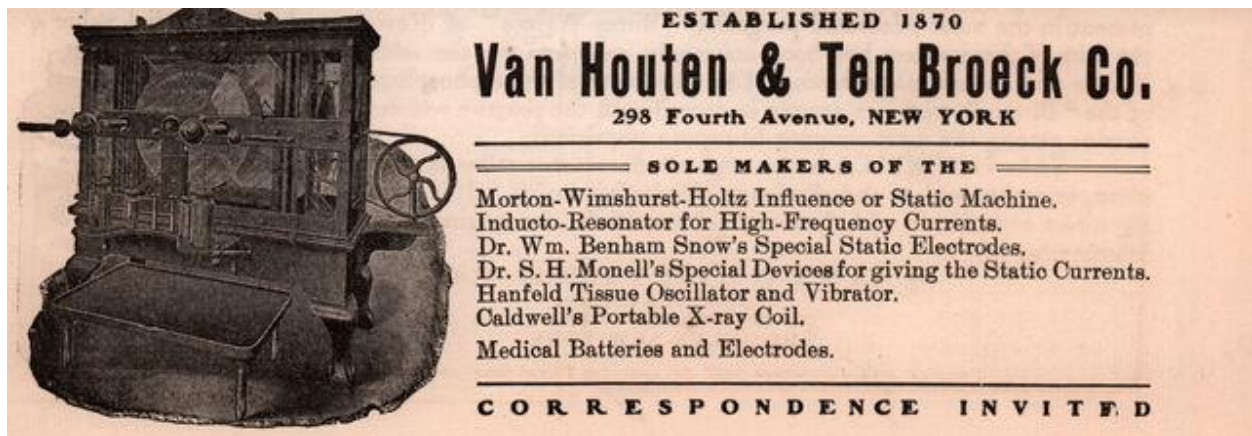

ESTABLISHED 1870

Van Houten & Ten Broeck Co.

298 Fourth Avenue, NEW YORK

SOLE MAKERS OF THE

- Morton-Wimshurst-Holtz Influence or Static Machine.
- Inducto-Resonator for High-Frequency Currents.
- Dr. Wm. Benham Snow's Special Static Electrodes.
- Dr. S. H. Monell's Special Devices for giving the Static Currents.
- Hanfeld Tissue Oscillator and Vibrator.
- Caldwell's Portable X-ray Coil.
- Medical Batteries and Electrodes.

C O R R E S P O N D E N C E I N V I T E D

12.10.2 (below) is a massive Static Machine offered by Van Houten & Ten Broeck. It has four sets of static wheels and stands over 5 feet tall. A static machine or electrostatic generator is a device that generates static electricity at very high voltage and low continuous current. They are often called friction machines as friction was a popular method of generating static electricity. It had uses in X-Ray tubes, and medical devices, to name a few.



Courtesy of Bill & Jill Meier.

12.10.2↑

It generated the power for the numerous electro-therapy machines. Note the glass legs on the bench under the machine. These machines generated massive amounts of power and anyone in contact with it had to be insulated, a situation similar to using insulators on chair legs in Fire Towers. In this case the patient sat in a chair on the insulated bench. Benches with glass legs were commercially available (12.2).



12.10.3 Isolation benches with glass legs



←**12.10.4** is a close-up of the glass legs. They are 11.5 “ long and 1.75” in diameter. The top two inches are threaded. Each leg is embossed V.H. & T.B. N.Y. Courtesy of Bill & Jill Meier

Lightning is a form of static discharge, which explains the reason for the glass legs as insulators.

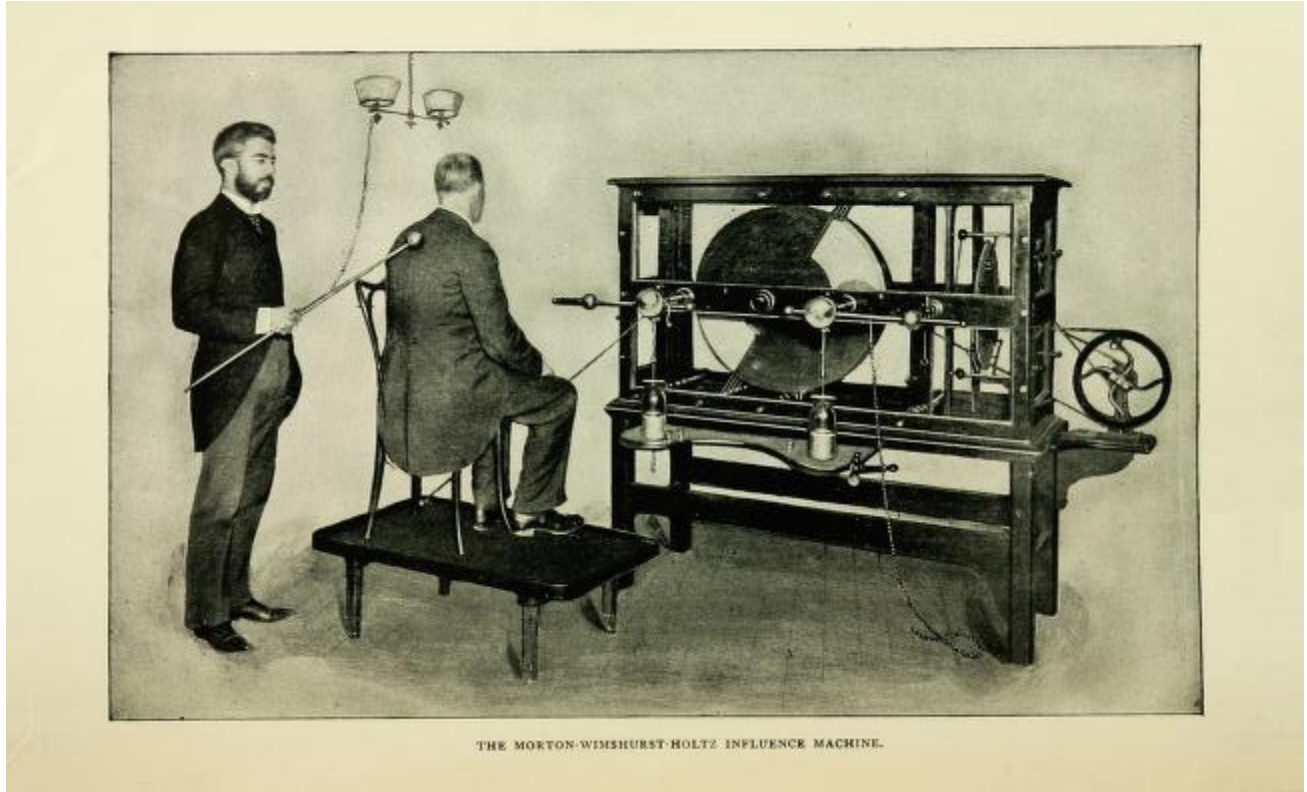

12.10.5↑ shows a static machine with the patient isolated on the bench with the glass legs.



← 12.10.6 Shorter legs were available as we see here.

Sole Western Agents
... For ...
VAN HOUTEN & TEN BROECK CO.
Static Machines
SCHEIDEL & COMPANY
X-Ray Coils
VICTOR ELECTRIC CO.
Vibrators and Specialties

These goods are the best that skilled workmen and money can produce and we guarantee them in every particular

To those who contemplate purchase, we respectfully submit that the Scheidel Coil is computed, designed and built by experts in electrical engineering. Write us for prices and complete description.

No. 4 Victor Combination Pneumatic and Mechanical Vibratory Massage Outfit

SHUTTS WALTERS & CO.
Surgeons' Instruments, Hospital
and Laboratory Supplies # #
534-536 SUTTER STREET
San Francisco - - - - California

12.10.7 ↑ states that Shutts Waters Co. are the sole western agents for Van Houten & Ten Broeck Co. Static Machines.



← **12.10.8** is a milliamperemeter, embossed, Van Houten & Ten Broeck Co. from one of their Static Machine.

12.11 C.F. BIRTMAN Co., Chicago

C.F. Birtman Co. of Chicago is a company that appears to be very similar to Van Houten and Ten Broeck. Again I could find very little about the company. Like V.H. & T.B. they produced Static Machines and X-Ray equipment.



←**12.11.1** is a milliamper gauge with the C.F. Birtman name.

Like V.H. & T.B. they had glass legs to insulate their equipment, as well. Such a set is shown in 12.11.2, below. These legs are also 11.5" long, and taper from 2" diameter at the threaded top to 1.5" at the bottom. They are rebossed around the top, C.F.BIRTMAN Co.



←**12 .11.2**

Although I could find very little on C.F. Birtman Co., I did find a patent(777,833) for a Static Machine issued to C.F. Birtman in 1904. If interested, it is included in Appendix K.

12.12 GALVANO FARADIC MFG. CO.



← **12.12.1** is a battery jar attributed to the Galvano-Faradic Manufacturing Co of New York, . It is un-embossed with dimensions of 1.25" x 2" x 3.5" tall.

According to the literature, they also supplied a jar very similar to 14.1. It is unknown if it was their own manufacture or if Whitall Tatum manufactured for them.

The advertisement is a detailed illustration of various electrical medical instruments and their packaging. At the top left is an open box labeled 'The Darkest Galvanic Battery'. Next to it is a case labeled 'Case of Electrodes'. In the center is a large, multi-story building labeled 'Manufactory and Office'. To the right is a box labeled 'Galvano-Cautic Battery' and a tall cabinet labeled 'Cabinet Regulator and Batteries'.

Below these are several smaller machines: 'No. 2 Electro-Magnetic Machine', 'New Combination Regulator', and 'No. 3 Electro-Magnetic Machine'. At the bottom left is a 'Galvanic Cell' and at the bottom center is 'No. 4 Electro-Magnetic Machine'. On the far right is a 'Needle and Holder'.

Galvano-Faradic Manufacturing Company
167 East 24th Street, New York

The Galvano-Faradic Manufacturing Company, of New York City, established in 1870, for the construction of Electro-Medical Instruments, are the most extensive manufacturers of the kind in the world, and construct the greatest variety of apparatus. Of these the principal machines are the Galvanic, Electro-Magnetic, Galvano-Cautic, Galvanic Combination and Permanent Batteries; to which are added a great variety of accessory instruments for the more scientific and exact application of the electric current to the human body.

Electro-Therapeutics, although comparatively a modern science, has spread over all the civilized countries of the world, until it has become a regular and essential part of medical study, and is certain ever to continue so.

The first mention we have of electricity as a remedial agent, it is true, carries us back to a remote period, when shocks were given to patients from the Torpedo or Electric Ray, found in the *Electricus*, and the *Malesherbes*, or *Electric Shark*, found in the Nile—creatures provided with a natural apparatus bearing a strange analogy to those constructed by human hands. But it was not until after the momentous discovery of Franklin, Galvani and Volta that the scientific world became interested in the matter; then, calling to their aid the Electric Machine and Voltaic Pile, physicians began to carefully study the effects of electrical currents upon disease. Some disengagement, as is usual in the introduction of new methods, attended the first attempts to effect cures through the agency of electricity, and in a short time it fell so far into discredit as to discourage experimental inquiry. It was not until some forty years later—about forty years ago—that Duchenne, an eminent French scientist, discovered the method of holding the appliances to the diseased organ, by which the remedial effect was

greatly increased. Duchenne's discovery gave a new impetus to the science. He continued his experiments and was assisted in his efforts to arrive at a perfect knowledge of the power and uses of the currents by some of the first makers of electrical instruments in Paris. But other scientists taking up the inquiry—especially such men as Du Bois, Raymond, Stokor, Noé and others in Germany, and Faraday in England—great advances were made, and many new varieties of machines constructed, with still improving parts, down to our own day, and our own country.

The Galvano-Faradic Company takes its title from the two most eminent of the discoverers, Galvani and Faraday; and, in emulation of these great men and of the others herein alluded to, have labored to improve the various apparatus, in which they have been so peculiarly successful that their machines have attained a world-wide celebrity, and are now in general use.

Considered simply in a mechanical point of view, they are beautiful inventions, singularly precise in their movements, and variable to an almost infinite degree in their effects; so that while America may claim the honor of having been among the first nations that endeavored to cure disease by electricity, she is also among the foremost in constructing thoroughly efficacious appliances for so important a purpose.

The engravings presented on this page represent but a few of the many varieties of electrical machines and appliances manufactured by the Galvano-Faradic Manufacturing Company. They occupy the large building situated at the corner of Third Avenue and Thirty-fourth Street, New York City, and keep in constant supply a large force of skillful and scientific workmen, who are taxed to their utmost capacity to keep pace with the constantly increasing demand for their instruments.

The Company will, on application, furnish any of our readers who may desire to know more of electricity as a remedial agent, and the best methods of applying it, with all required information.

12.12.2↑ Is a page from an advertisement of the Galvano-Faradic Manufacturing Co. of New York. This is one of many companies offering Medical Batteries; most of which had catalogs describing their offerings.

Fig. 4.

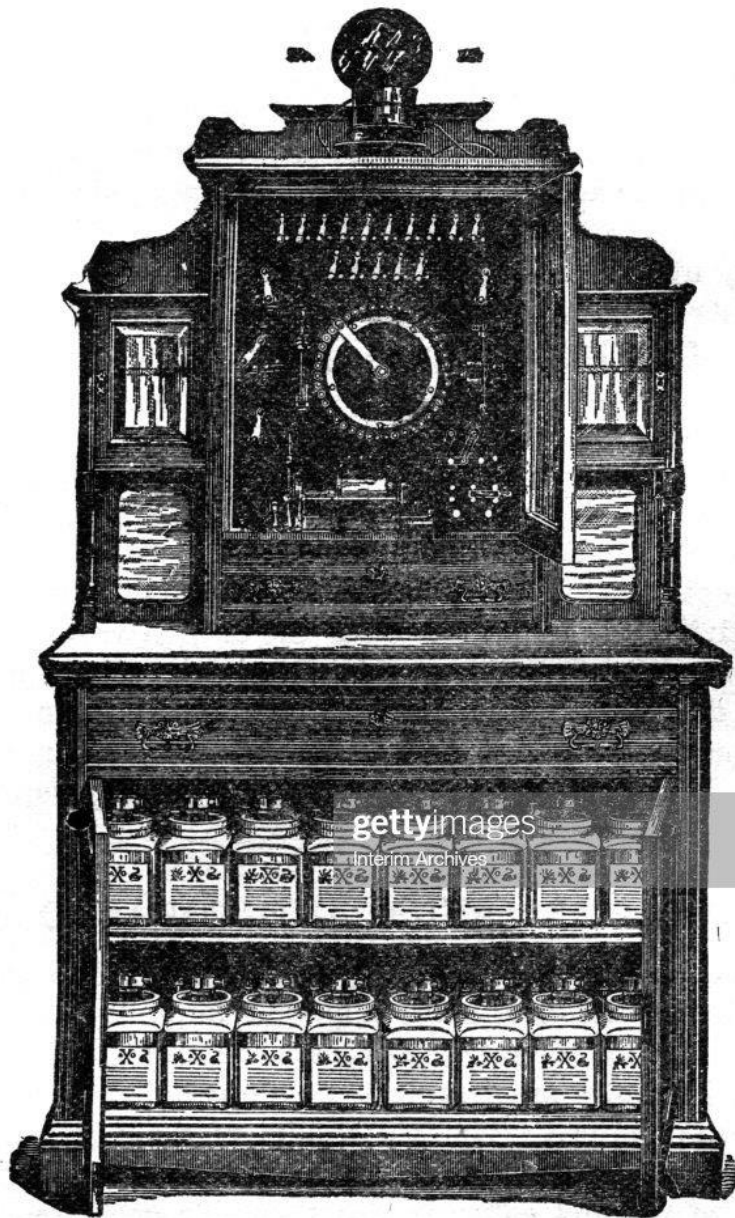

Our large 40 cell Galvano-Faradic Battery with Switch-board.

12.12.3 ↑ shows a Galvano-Faradic Battery for clinical use.



A medical battery from the Galvano-Faradic Manufacturing Co.
12.12.4↑

They published a paper “Practical Chapters on Static Electricity” by S.H. Monell M.D. of New York. It is presented in its entirety in Appendix G.

12.13 WAITE & BARTLETT MFG. CO.

Unfortunately, I was not able to find much information on the Waite and Bartlett Mfg. Co. of New York. It was founded by Henry E. Waite, M.D. and S.H. Bartlett in 1881. They were active in supplying medical batteries for both clinical and home use, as seen in their catalog of 1895 and 1896. Their catalog of 1920 offered only surgical supplies. They also supplied X-Ray equipment. I found the following patents assigned to Henry E. Waite and/or Henry E. Waite & Stephen H. Bartlett:

Patent #	Issued	Title
262,532	8/8/1882	Switch for Telephone
287,896	11/6/1883	Telephone Receiver
316,204	4/21/85	Microphone
497,226	5/9/1893	Influence Machine (Medical Battery)
422,174	2/25/1890	Grinding Electrode for Microphone
674,890	5/28/1901	Static Machine

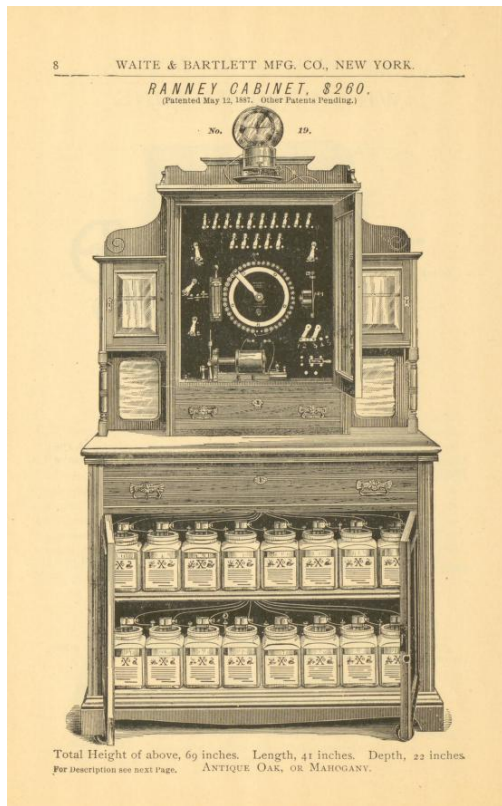

←**12.13.1** is a picture of their RANNEY CABINET for use in Clinics and Physicians offices. Excerpts from their 1895/1896 catalog are shown in Appendix,



12.13.2↑



12.13.3↑

12.13.4↓



12.13.4↑

12.13.2 through **12.13.4** are battery jars embossed Waite & Bartlett. They are Specialty batteries, likely used in Medical batteries.

12.13.2 is embossed (arc) WAITE & BARTLETT / N.Y. It has the same dimensions as **12.2.6** and is likely, also, made by Whitall Tatum.

12.13.3 is embossed (arc) WAITE & / BARTLETT / N.Y./ MFG. CO. Its dimensions are 1.25" x 2" x 3.75". Notice the beveled edges.

12.13.4 seems to be the clear glass version of **12.13.3**, with slightly different embossing. This version has a Patent Date of JULY 22 90 added beneath MFG. CO. Their dimensions are: 1.25" x 2" x 3.375

12.14 OTHER MEDICAL BATTERIES

This section highlights other Medical Batteries that existed, but on which I could find no information.



←12.14.1

12.14.1 and 12.14.2 show Osgood's Eureka medical battery. It is complete with battery jar (12.14.3). Courtesy of Tommy Bolack.

12.14.2↓





← **12.14.3** is the Battery Jar associated with Osgood's **Eureka** Medical Battery. The jar is rectangular in shape with dimensions of 2.5" x 3.74" x 4" tall, with a hard rubber lid.



←**12.14.4** is another medical battery. The plate in the top reads: **"THE DOW" / Portable Electric Assistant / Patent Applied For / G.N.CLAPP & Co. Sole Ag'ts. / BOSTON, MASS.**



←**12.14.5** shows a medical battery from “The MURRAY-BAUMGARTEN Surgical Instrument Co. / 216 West Franklin St / Baltimore , MD.



←**12.14.6.** Little remains of a J.H.Bunnell medical battery.

12.14.7 ↓

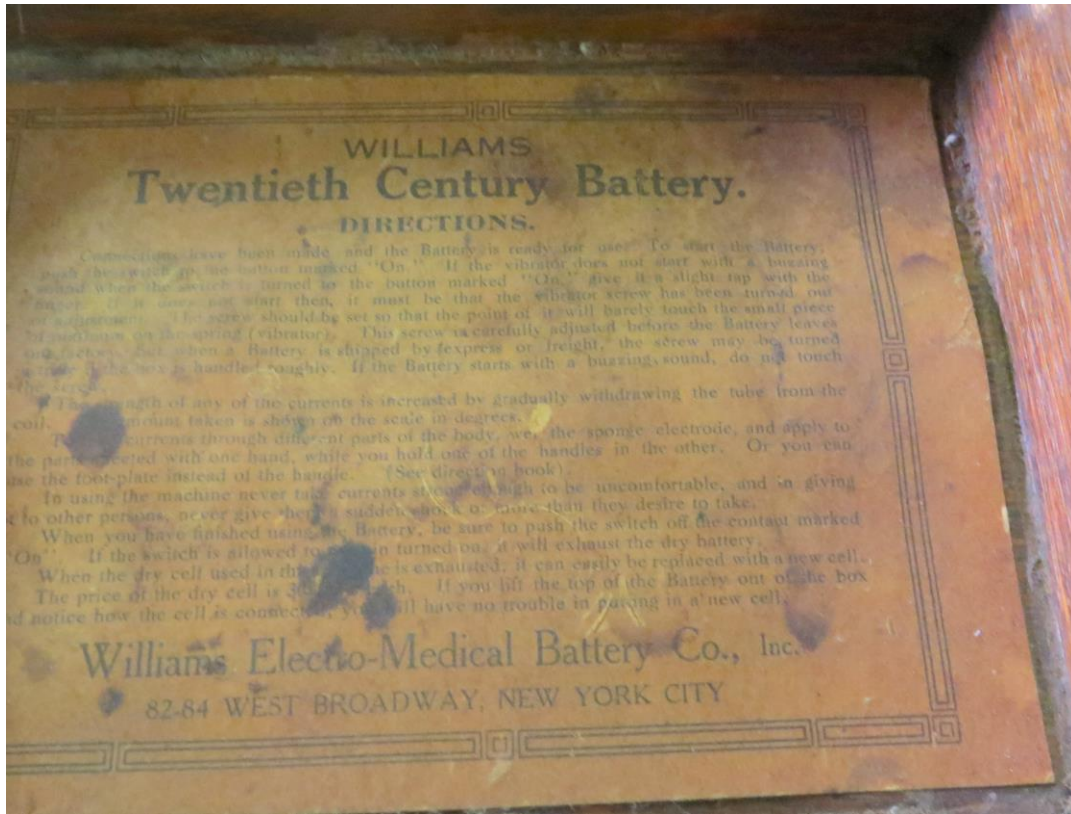

12.14.8↓



12.14.7 through 12.14.9 are different versions of Williams Electro Medical Batteries.

12.14.7 and 12.14.8 are courtesy of Tommy Bolack.

Many other companies offered medical batteries, other than those shown. Included in those and not shown are Westinghouse, Pilling, Partrick & Carter just to name a few.

12.15 Violet Ray

As the world became electrified the wet cell electro-therapy gave way to AC powered devices. The most common was the Violet Ray. It was merely ultraviolet, which glowed purple. I believe the color, at the time, fascinated people and a new craze was born. The craze with the Violet Ray lasted well into the 1940s. I won't spend a lot of time on Violet Ray, as they didn't use batteries and/or battery jars. It was, however, a continuation of the electro-therapy craze that came to be known as Quack Medicine. I would be derelict if I didn't mention it.

As we saw before, this craze was not only in the United States, but world-wide. Edgar Cayce, a popular clairvoyant of the early 1900's popularized the Violet Ray, and his followers helped to promote it. Cayce was known as the "Sleeping Prophet," as his prophecies were revealed to him in a trance-like state. He awoke with this new knowledge. I have references in the Bibliography should you want to learn more about Edgar Cayce.

The Violet Ray, (U-V) treatment is making a comeback, of sorts. It is used to heal the skin and promote blood flow among other things. It is only used by Doctors and Clinicians for professional use. Gone are the wild claims of it being able to cure everything.



12.15.1



12.15.2



12.15.3

12.15.1 through 12.15.3 show a Violet Ray Machine that was made in Germany. As you can see, with all the attachments, it requires two cases to hold it all. The ads at the time, touted the attachments, at least one for every body orifice.



←12.15.4 is a Violet Ray machine of unknown origin



←**12.15.5** is a violet ray machine from Garrett & Osborn of London, England.



5

←**12.15.6**

12.15. 6, above, shows the Marvel No. A-1 Ultra Violet machine manufactured by Eastern Laboratories, Inc. of NEW York. It was patented in 1924 and was touted to offer the following:

Soothing effect, Stimulation and Invigoration, Pain Relief, for the treatment of Rheumatism, Lumbago, partial paralysis, Neuritis, Headaches, Insomnia, Brain Fog, Hair Growth, Return Gray hair to the normal color, Dyspepsia, Constipation, Digestive Disorders, Reproductive problems in men and women, etc.

The list of ailments treated by ultra-violet reads like the list of ailments treated by medical batteries discussed earlier. **12.15.7** (below) shows some of the attachments that were available for The MARVEL

MARVEL

HIGH FREQUENCY GENERATORS



MARVEL No. A-1 Price \$12.50

High grade, well built, one-piece instrument. Equipped with surface electrode.



SUPER MARVEL No. 3 Price \$16.50

Finely built, one-piece instrument, packed in lined carrying case. Equipped with surface, comb and throat electrode.

The Marvel High Frequency Generator is not a cure all. It has a definite place in the medical field.

Many human ailments are traceable to imperfect circulation. The stimulating effect of the generator aids in the promotion of circulation and that is its primary function.

For all specific ailments, your family physician should be consulted regarding the use of the generator, as he naturally knows your condition and will recommend treatment if it is indicated in your case.

MARVEL ELECTRODES

(Made to fit all standard instruments with 7/16" ID electrode socket holder)

- 

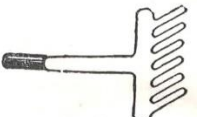
S-1 Surface \$1.20
- 

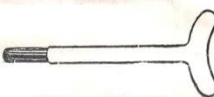
S-3 Comb \$1.80
- 

S-5 External throat \$1.20

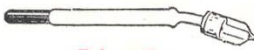
- 

S-20 Fulguration \$2.40

- 

No. S-6—Metal electrode or Saturator, used in giving indirect treatments\$1.50

- 

S-4 Spinal \$2.40

—ELECTRODES CANNOT BE EXCHANGED AND ARE NOT GUARANTEED—

ADDITIONAL LIST OF ELECTRODES ON OTHER SIDE

EASTERN LABORATORIES INC

216-226 EAST 45TH STREET

NEW YORK (17), N. Y.

12.15.7↑

12.16 POCKET BATTERIES

The popularity of the medical battery led to a need to downsize the batteries to something that could be carried in a pocket or purse. This enabled you to carry the battery with you to use anywhere, anytime, not only at home.

A pocket battery is nothing more than a medical battery reduced in size so as to fit in a pocket or purse. Somewhat surprisingly, most of the pocket batteries discovered to date have used wet cell technology, but on a much smaller scale.

12.16.1 SMITH & SHAW ELECTRIC CO.



←**12.16.1.1** is a medical battery manufactured by Smith and Shaw Electric Co. of New York. It was touted to cure all kinds of ailments. It was powered by one or two closed cells, also manufactured by Smith & Shaw. It is called a pocket battery, as it was designed to be carried with you. It is a single cell uni, and measures 6" x 3.5" x 1.25" high, O.D. A double cell version measured

12.16.1.2→ is the double cell version of the Smith and Shaw pocket medical battery. It measures 7.125 x 3.875 x 1.5" high.





←**12.16.1.3** is the battery used in the Smith & Shaw units shown above.



12.16.1.4→

12.16.1.4 shows the anode on the **12.16.1.3**.

bottom of

I could find no information on). The Smith & Shaw Electric Co. They were located at 168 West 34TH St., New York, and were in business in the 1880s. Just when they incorporated is not known. It is known that they marketed in the 1880s, a closed cell pocket battery, (above). They describe it as: *“Combining Improvements of so Radical a Nature as to make it the Battery Of The Age.*

A pamphlet by Smith & Shaw describing the battery is duplicated in Appendix F.

The Smith & Shaw medical battery used Mercury Bi-Sulphate, which today is a hazardous substance. In the late 19TH and early 20TH centuries the dangers of Mercury compounds were unknown. And yet, because the dangers were unknown, we had everyday people mixing their own chemicals to prepare the batteries. It is purely speculation, but could it have led to the seeming unpopularity of the pocket battery.

12.16.2 DR. DRESCHER



←**12.16.2.1** shows another pocket-sized medical battery. It is the Dr. DRESCHER'S Pocket Electro-Magnetic Machine No. 1. A patent in the name of Dr. Drescher, for what I believe is this machine, is included in the Patents section, Chapter 77. The insert in the lid identifies it as Dr. Drescher's machine. It was manufactured by F.G. Otto & Sons, who are listed as the sole proprietors of Dr. Drescher's Patent Electro Medical Apparatus. There is a small insert which reads Otto Fleming / 729 Arch Street / Philadelphia, PA.

Otto Fleming was a physician in Philadelphia, who in the early 1880s patented "Otto Fleming's Electric Machine and Induction Coil", known as

Faradic Battery No. 1. Dr's Drescher and Fleming were obviously supporting and endorsing each others machines.



←**12.16.2.2** a picture of Dr Drescher's Pocket Electro-Magnetic Machine No. 3, also manufactured by F.G. Otto & Sons. Reading the cover insert shows that it used a Bisulfate of Mercury battery, Likely similar to what we saw in **12.16.1.1** to **12.16.1.3**, for the Smith & Shaw pocket battery. The dimensions of the box are 7.5 x 4 x 1.5" high

It is a little strange that neither of Dr. Drescher's pocket batteries could have used the battery jar with his initials on it,

12.17 MEDICAL BATTERIES FROM OUTSIDE THE U.S.

With everything that was happening in this country at the time, we easily forget that the entire world was awaking to the wonders of electricity at the same time. Not to be out done, manufacturers from other than the U.S were involved in the medical battery business.



Charles Chardin of France offered medical batteries as seen in **12.17.1**↑ and **12.17.2**↓.





INSTRUCTION

Pour l'emploi du N° A 29 du Catalogue général.

La Maison n'expose plus.

Seuls Appareils dont le fonctionnement puisse être garanti.



Fig. 5 1. — Appareil tel qu'il est livré.

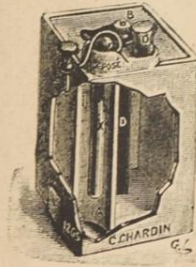

Fig. 1265-2. — Pile en porcelaine.

PINCES MÉTALLIQUES (appelées Bornes)



Fig. 394-3.



Fig. 1717-4.

LÉGENDES: Fig. 3. — A, pince recevant les pitons (voir fig. 16) des cordons et du zinc (fig. 23); B, trou dans lequel le piton doit pénétrer pour rester rigide.
Fig. 4. — Principe du système, la pince doit être dans l'encoche du piton et celui-ci se voir ou se supposer en A.



Fig. 1332-5. — Séparation de la pile et de l'appareil. Ne pas la charger dans la boîte.

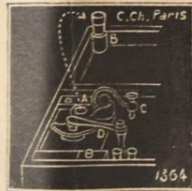

Fig. 1364-6. — Le bouchon B de la pile est déposé dans le godet noir; c'est une manœuvre importante.



Fig. 1228-7. — Chargement de la pile. Introduction du liquide; contenance: 125 gr. environ. Observer le niveau.



Fig. 1234-8. — Situation de l'appareil prêt à être utilisé pour une application. Mouiller les électrodes. (Voir fig. 21.)

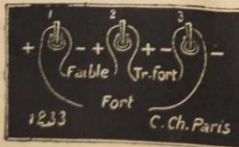

Fig. 1233-9. — Rôle des trois bornes 1, 2, 3 (fig. 8) prises deux par deux. Les pôles varient suivant la combinaison.

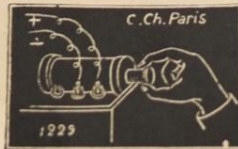

Fig. 1229-10. — Graduation du courant. On l'augmente en tirant le graduateur jusqu'à le sortir complètement.

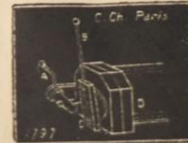

Fig. 1797-11. — Secousses lentes automatiques. Visser le pendule dans le trembleur et régler par la pièce A à volonté.

12.17.3↑ is a page of instructions that came with 12.17.1



12.17.4 ↑



12.17.5 ↑

12.15.4 and 12.15.5 are porcelain battery jars used in the Chardin medical batteries.



12.17.6 is a medical battery from Garrett & Osborn of London, England. From the picture it appears to be a Violet Ray (Ultraviolet) machine that ran on household current rather than batteries.



← **12.17.7** is a pocket battery from A. Gaiffe of Paris, France.

13.0 RAILROAD SIGNALING

Railroads were not always about safety, which led to numerous accidents. As long as the death toll was low no one really cared. The false sense of security was caused by a few things:

- The entire country had only 1,098 miles of track in 1835. In 1950 this had only increased to 9,021 miles of track.
- Train trips were short.
- Trains did not run at night.
- Due to poor tracks, train speed was in the range of 10 to 18 miles per hour.

About 1850 railroads expanded rapidly, much of it using cheap construction. Compared to England, American railroads were cheaply many times with shoddy workmanship and materials. American railroads had sharp curves, steep, bumpy grades and poor construction techniques. English rails were built for permanence and quality. They used double tracks to eliminate collisions, bridges were stone rather than wood, curves were generous and grades reduced. We, on the other hand, merely laid track as quickly as we could. Government policy actually encouraged shoddy construction through the land grant program, which gave the railroads land and loans only after track was installed.

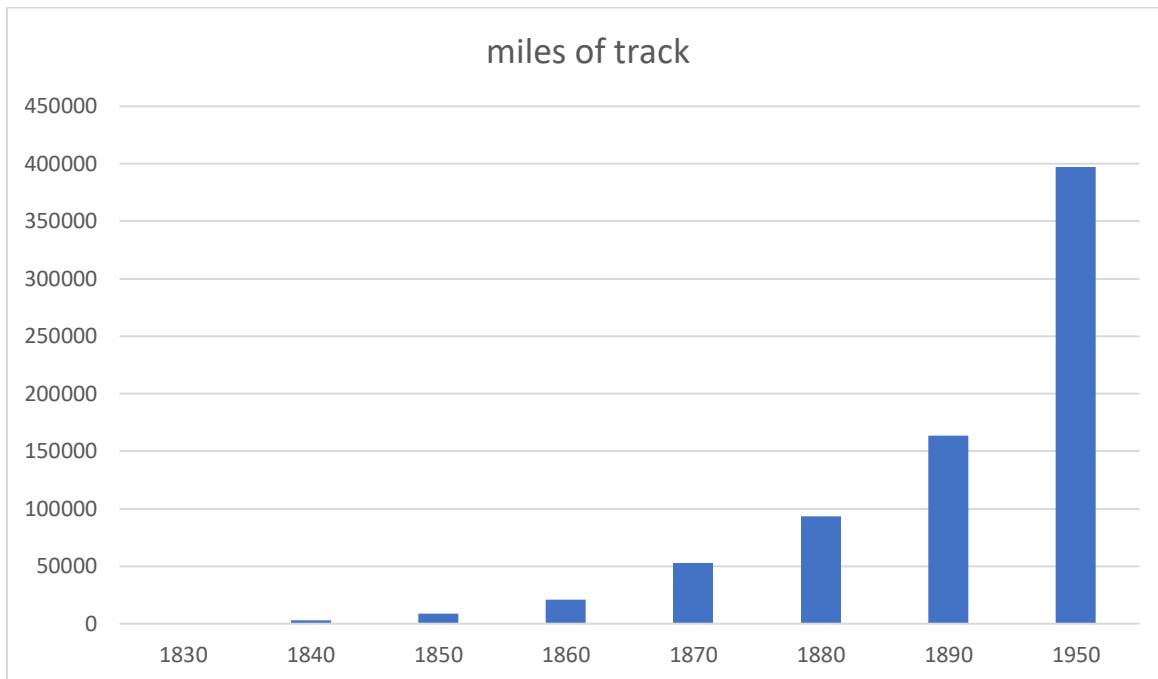

13.1 ↑ shows the exponential growth of the railroads in the U.S. during this period. By 2014 the Miles of Track had declined to 161,000 miles, about what it was in 1890

Appendix I shows U.S. maps with railroad tracks laid by the decade.

All of this helped to set the stage for rail disasters that began in 1853. In that year alone 234 passengers were killed. Many accidents and deaths were caused by derailments, bridge collapses, boilers bursting, etc.

Up to this time trains ran on the Time Interval Rule. It was a safety system based on timetables alone. The problem was knowing where a train was, even if you couldn't see it. .

- If one train was delayed, waiting trains had to wait one hour.
- A brakeman would walk 20 minutes ahead with a red flag.
- The engineer would move the train forward to the first brakeman and send a second brakeman another 20 minutes forward.
- This process was repeated until the train reached the next scheduled stop.
- With the train, now, found, a new schedule was set.

As you can see this system was exhausting, cumbersome and time consuming, with many engineers taking it upon themselves to change the rules.

This was coupled with the advent of emigrant trains, which were used to move new arrivals to this country west to new opportunities. These trains were overloaded, used old equipment, and were run as specials, outside of the schedules and timetables of regularly scheduled trains. As a result no one knew where they were and essentially, and, by default, they became targets. Our single track system, at the time led to head-on and rear-end collisions, most of which were attributed to human error, at the time. Most of these would have been preventable had we had a system in place to know where trains were.

The first signals used on American railroads were flags used in the 1830s. This was followed by a system of balls hoisted up or down a pole. This was first used on the New York and New Haven Railroad in 1852. Signals were changed based on telegrams received at each signal station. One thing the early signaling systems had in common, was that they required an attendant at each railroad crossing to manually change the signals.



←**13.2** shows an early ball system of signalling, with the small building where an attendant sat waiting for instructions. If the track was clear a red ball was raised to the top. This became known as “*High Balling*”, a term that is still used.

13.3 → shows a later mechanical system, still requiring an on-site attendant.

The Union Switch and Signal Co., founded by George Westinghouse in 1881 was in the forefront of automatic signalling, developing automatic electrical systems, which were widely used by the 1890s.

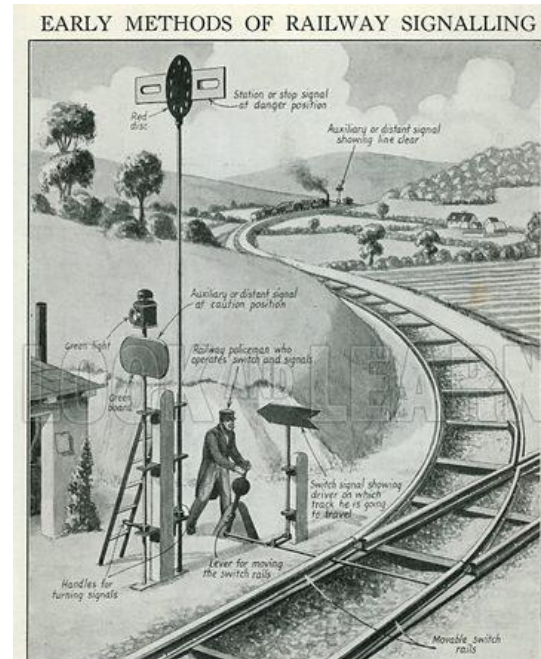

For those that are interested in a beginner's guide to signaling, I refer you to:

-
- <https://econstructioncareers.com/news-insight/rail-signaling>
- www.chartertoconductor.com/railroadsignals.

Railroads were a major user of battery jars to power track Block signals to alert trains and others of possible dangers. The batteries were generally kept in boxes adjacent to the signals.

Many times, on porcelain battery jar lids you will find the initials *R.S.A.*, *A.R.A.*, *A.R.S.* These stand for: *Railway Signal Association*, *American Railway Association* and *American Railway Signaling*, respectively. These associations worked together to insure and improve railway safety. These various organizations had manuals of practices and procedures on signaling, many of which originated in England and were brought to the United States.

Signal lights soon became an important part of signalling. The earliest signal lenses were used in lanterns, with lens color being of utmost importance. There could be no mistaking colors or an accident might happen. This issue was further complicated by the fact that the lamps used orange-tinted fuels, which changed the resultant color. The work of Dr. William Churchill at Corning Glass Works resulted in the adoption of six RSA standard colors. They were officially accepted by the R.S.A. on Oct. 10, 1905. Photos **13.4** to **13.5** show these official colors.



←**13.4:** The official RSA signal colors. Left to Right. (Top) RSA Red, Yellow, Green. (Bottom) RSA Purple, Blue, Lunar White.



←**13.5:** The opposite sides of the three bottom lenses in **13.4**. Left to Right. RSA Purple, Blue, Lunar White.



←**13.6:** The RSA Purple, Blue and Lunar White lenses from **13.4** and **13.5**, when lit. Note the change in color.



←**13.7:** The RSA Green and Blue Lenses when lit.

The standard colors were (and remain) RSA Signal: Red, Yellow, Green, Blue, Purple and Lunar White. Lunar White is a pale blue glass that, when lit, appears as pure white, just like the light from a full moon. In time, these color standards were adopted by the U.S. Federal Bureau of Standards, not just for railroads' signal light colors, but for navigation, highway and aviation signal lights. They eventually became the world-wide standard for all transportation signal colors for day and night use.

Keep in mind that the A.R.A., R.S.A. or A.A.R. designations were only found on the porcelain lids. The battery jars to which they were fit were standard glass jars. To date, I have found the signal designation on the following lids:

- L.S. Brach Chapter 9 A.R.A., Lid Only
- Edison (BSCO) Chapter 17, R.S.A. Lid Only
- Edison (BSCO) Chapter 17 R.S.A. Porcelain Jar & Lid.
- National Carbon Chapter 36 A..A..R. Lid on Corning Jar
- National Carbon Chapter 36 R.S.A Lid Only
- Union Carbide & Carbon Chapter 54 A.A.R. Lid on unembossed jar
- Waterbury Chapter 59 R.S.A Lid Only
- Waterbury Chapter 62 R.S.A. Lid on Whitall Tatum Jar

13.1 DR. WILLIAM ROBINSON

The block system was developed in the 1860s to help control rail traffic. Dr William Robinson championed the block systems, until it was perfected.

His first endeavor was the “Open Circuit” system, which he exhibited at the American Institute Fair in NYC in 1870. It consisted of isolating sections of track into blocks. A low voltage was applied across the tracks from battery jars placed adjacent to the tracks. If a train entered the block a circuit would close via a relay. When the train exited that block of track, the circuit would automatically open. Messages could be sent to the applicable signal stations to change the signals. Although the exhibition seemed to be a success, Dr. Robinson found several serious flaws:

- A train enters the block and drops off a car or more, then exits. As it exits the system will show an “all clear”, not knowing the train had separated.
- A train may enter from a siding or from the opposite end, not affecting the signal, which still shows “all clear”.
- If a line wire should break or the battery fail, the system will show an “all clear” signal.

This led Robinson to the Closed Block system, which is still used, today. As in the Open Block, the tracks are electrified on one end of the block, as before. In this case, however at the other end of the section, a relay magnet is connected to the opposite rails. Thus the current passes through the whole length of the block, keeping the relay on continuously closed circuit as its normal condition. A train entering from any direction will short circuit the current from the relay, instantly opening the signal circuit to the “Danger” position.

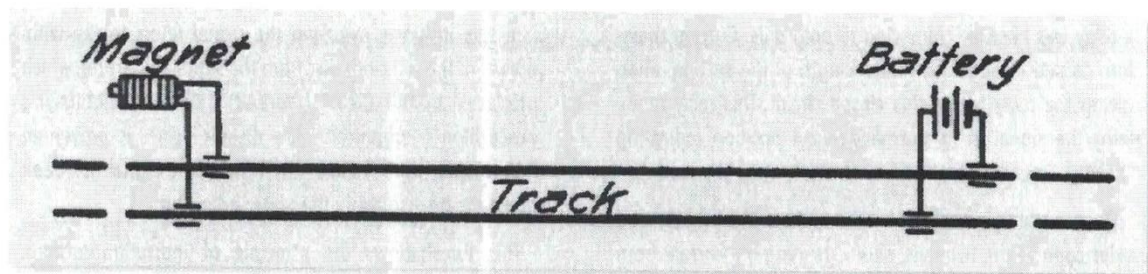

13.1.1↑ is a simple schematic of the Closed Block system.

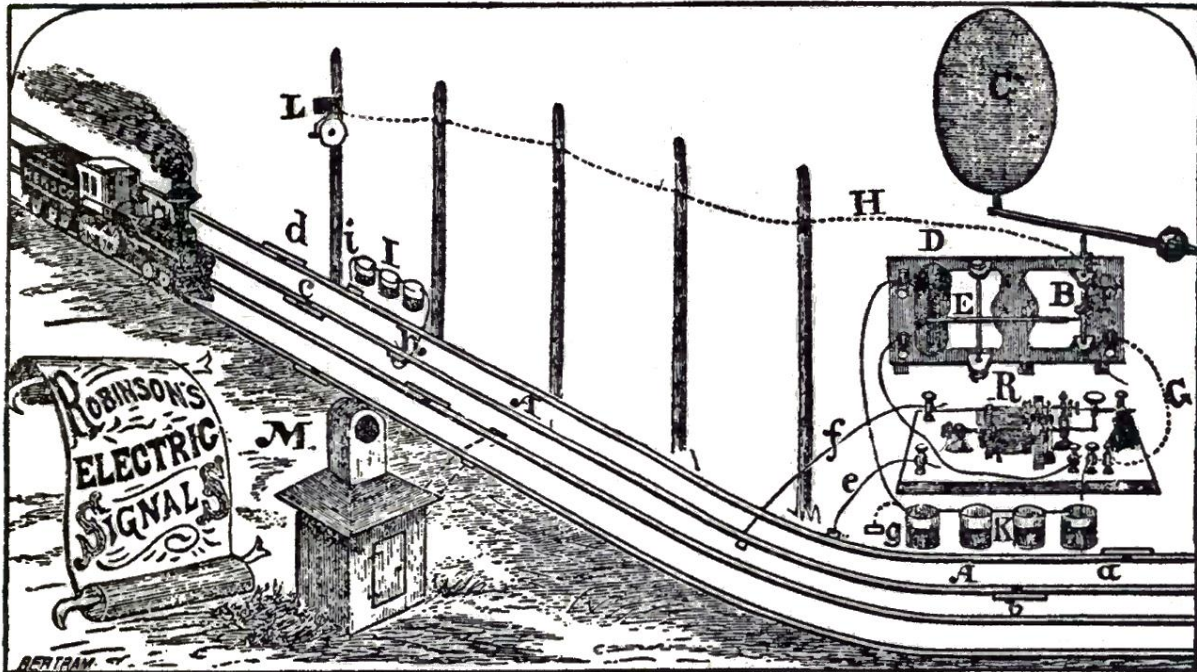

13.1.2↑ is a more elaborate schematic of the Closed Block System.

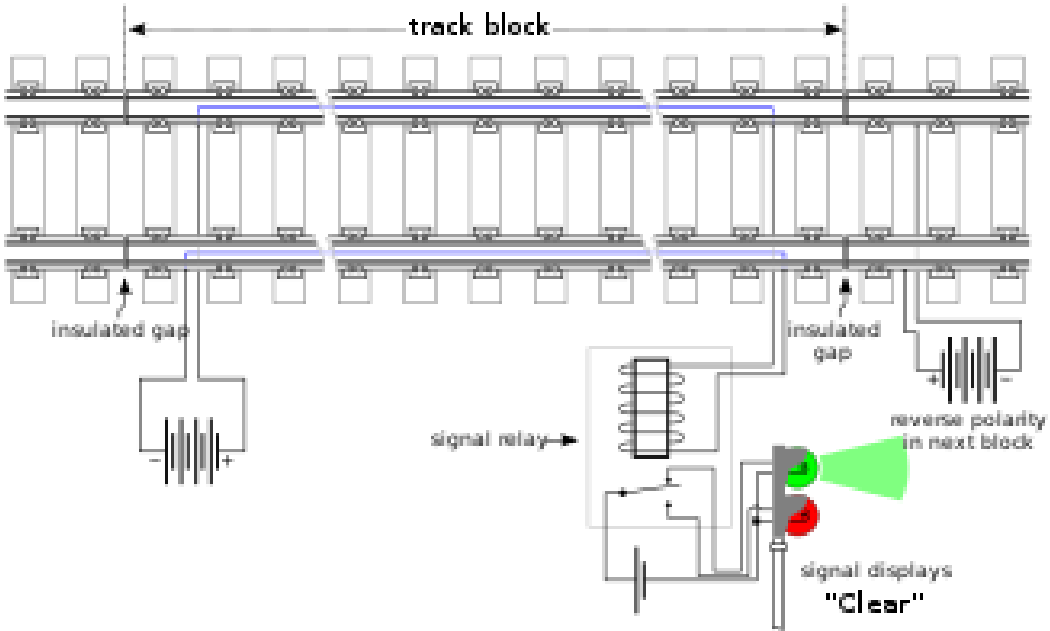

13.1.3↑

13.1.3 and 13.1.4 are other schematics of the Closed Block system, one showing an unoccupied block and the other an occupied block.

13.1.4↓

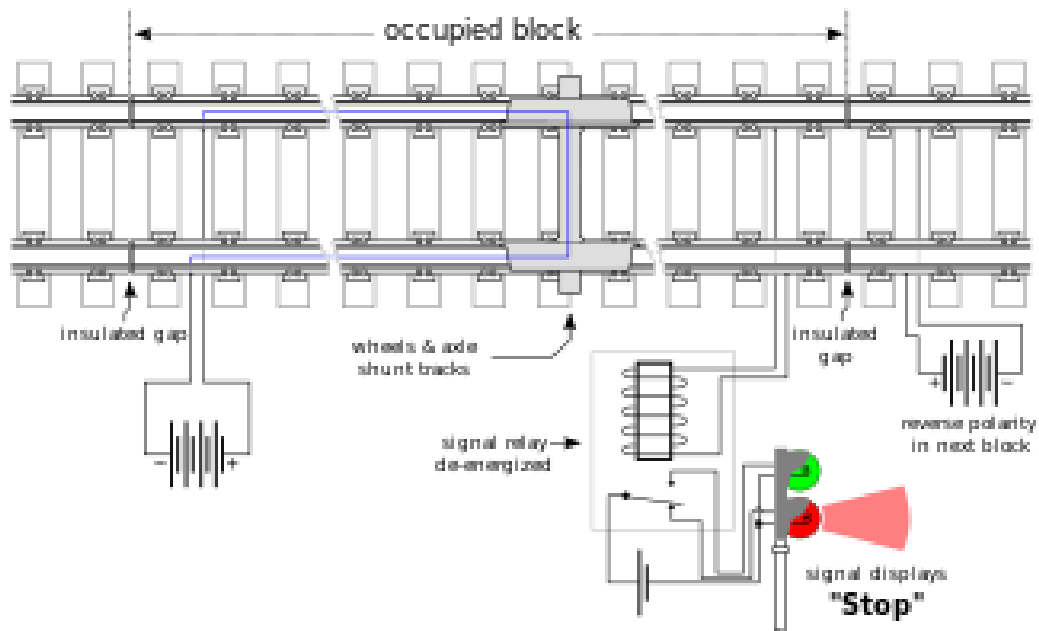

For more in-depth information, I recommend: <https://railroad signals.us> It provides somewhat of a history of signaling starting with Semaphore and going through the various types such as Search Light, Color Light, Position Light, Trilight as well as the types of signaling used by each railroad.

Although standardization of railroad signalling has come a long way, some of the older and smaller railroads still use different signalling methods, which requires engineers to be familiar with different systems.

13.2 RAILROAD SIGNAL JARS AND LIDS

Although many companies manufactured battery jars for Railroad signaling, Corning jars seem to be the most common.

Similarly, Edison lids have been the most common found with the signaling designations. That being said, I have found some with Waterbury, Union Carbide and National Carbon embossings.

13.2.1→ is a Corning jar with a National Carbon Co. lid. The lid **(13.2.2)** is embossed (arc) A.A.R. SIGNAL CELL / NATIONAL CARBON CO. INC. / NEW YORK, N.Y. / Made in U.S.A.





13.2.2↑



←13.2.3 is lone Edison Lid.
 It is embossed (arc) R.S.A.
 SIGNAL CELL / EDISON /
 <BSCO> / PRIMARY
 BATTERY / patented / other
 patents pending / Reg. U.S.
 Trade Pat. Off. / Thomas A.
 Edison (script) / Mark / (arc)
 THOMAS A. EDISON INC.
 ORANGE, N.J.



←**13.2.4** is a lone Waterbury lid, embossed: (arc) PATENTED / (arc) Oct 27, 1886 April 13, 1897 / (arc_ A.R.A. SIGNAL CELL / THE WATERBURY BATTERY CO. / WATERBURY / CONN. / U.S.A.



← **13.2.5** is a lone National; Carbon Co. lid, similar to **13.2.1**. This one is marked R.S.A. rather than A.A.R. Signal Cell. This one is embossed CLEVELAND, O rather than NEW YORK, N.Y. This one has not Made in U.S.A. embossing.

The Country of Origin label became mandatory in 1891, making **13.2.5** older than **13.2.1**.



←**13.2.6** is a Corning battery jar embossed : Made In U.S.A. / 9BJ2 / CORNING. The dimensions are 6.75" diameter x 11" tall. The lid is the same as **13.2.5**.

It should be noted that a 9BJ2 jar has been found with an EDISON lid, identical to that of **13.2.3**.



←**13.2.7** is a lone porcelain lid from the National Carbon Co. Embossed: (arc) **A.A.R. SIGNAL CELL / contains caustic / (arc) NATIONAL CARBON COMPANY / (arc) A Division of U.C. & C. Corporation, New York, N.Y. Made in U.S.A.**



13.2.8↑



13.2.9↑

13.2.9 is porcelain lid found with the battery jar in 13.2.8. Because of the separate port in the lid for adding battery oil, this may have been an early Edison signaling lid. As of now there is no evidence to support this assumption.



←13.2.10 is a porcelain lid for a signal jar. It is embossed (arc)A.R.A Signal Cell / L.S. BRACH Mfg. Co. / Newark, N.J.

14. TELEGRAPH AND TELEPHONE

As I stated earlier, there were those who looked at electricity as a great idea in search of an application. Anything that could be electrified, was. Telephone, Telegraph, Doorbells, Phonographs, radios and countless other applications were electrified. The one thing they had in common was a battery jar in which to generate the electrical current. You could almost play *Fill in the Blank* with the application, doorbell, etc.

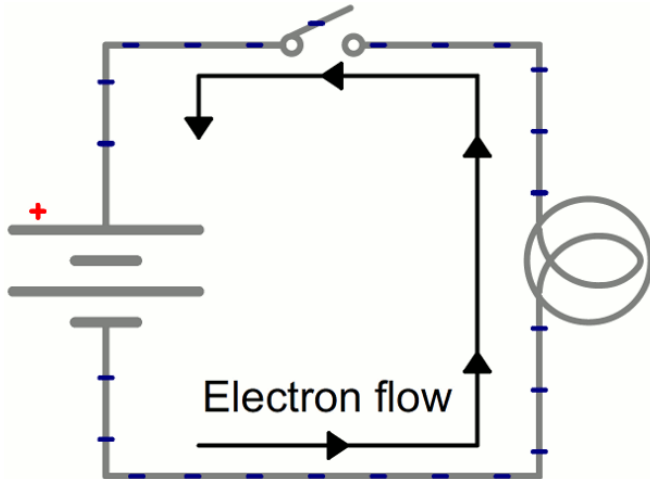

←**14.1** is a generalized depiction of an electrical circuit from Chapter 3. You could replace the light bulb with almost any application and be correct. Battery size, etc., may vary, but the general concept is the same.

14.1 TELEGRAPH

Telegraph is a device for sending and receiving messages over long distances. It was first used commercially by Cooke and Wheatstone in England in 1837. They had developed it for railway signaling, but the railroads in England rejected it in favor of a short-range system.

Whereas most early systems used multiple wires, the system developed by Morse, in the United States, was a single wire system. By 1844 the Morse telegraph system had connected Baltimore to Washington, and by 1861 the east and west coasts of the American continent were connected.

The telegraph became a means of general communication. A revised Morse system was adopted as the standard for continental European telegraphy in 1851, which was to become the basis of the International Morse Code. England, however, continued to use the Cooke & Wheatstone system, as late as the 1930s, in some places. This required translation specialists familiar with both systems for International messages.



←**14.1.1**, the cover picture of Volume II, shows a typical telegraph set-up (circa 1860). Notice the two battery jars, on the left, to power the unit.

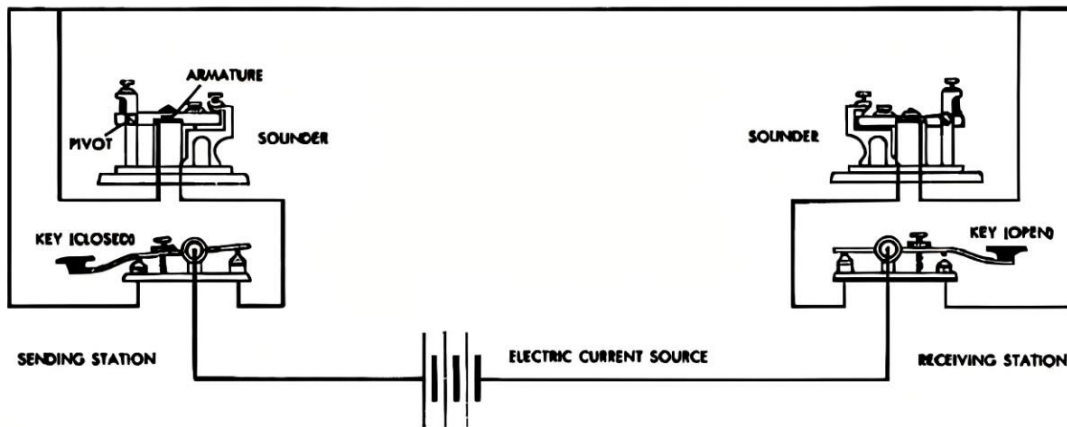

14.1.2↑

The simple schematic in **16.1.2** shows the basic telegraph set up. You have your power source, which was a few battery jars, the telegraph key and the sounder. The power source was one or more battery jars connected in series. The number of jars needed depended on the distances involved. **14.1.3** (below) shows a battery jar set-up for long-distance messaging.

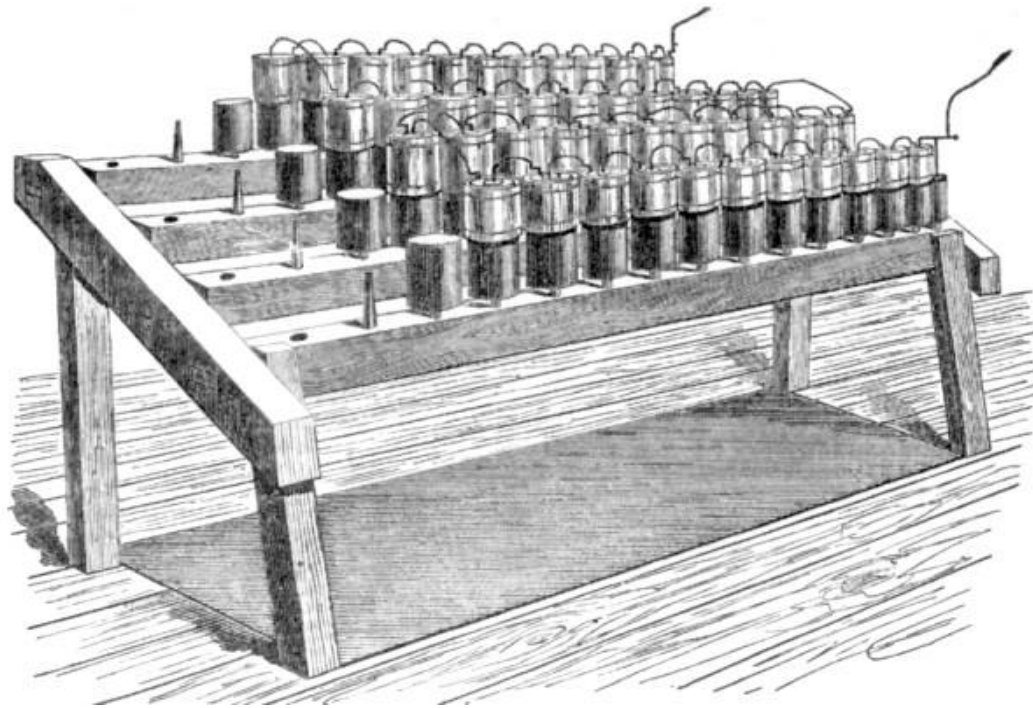

14.1.3↑

What I termed as “Quart” battery jars were likely used for telegraph service.

The telegraph key was basically a switch which was turned on or off by the operator. Depressing the key, briefly, creates a short signal (dot). Depressing it for a moment creates a longer signal (dash). A sequence of dots and dashes represents letters and numbers.

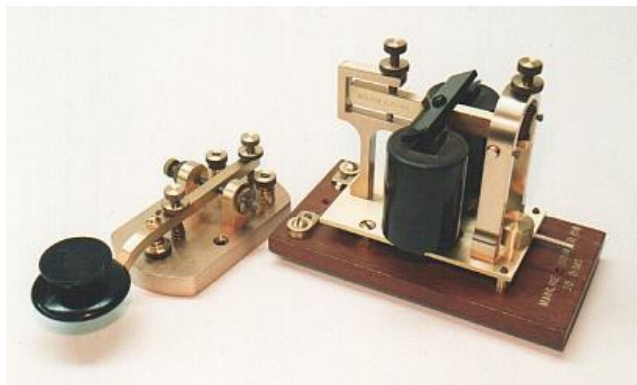

←14.1.4 shows a telegraph key and a sounder, two integral parts of a telegraph system.

The early telegraphs used electromagnets as seen in the schematic. It pulled on a piece of iron when a current passed through it. These devices caused marks to be made on a paper tape creating a copy of the message which was then deciphered by the operator. When it was known that operators could decipher the clicking noises simply by listening, the electromagnets were

converted to electromagnetically operated sounders. The sounder converted the dots and dashes into more audible sounds which made the translation much easier for the operators. The sounder was later modified by placing in in a box which amplified the sound, making the sounds much more audible.

American Morse Code

<p>.....</p> <p>-----</p>			
A --	N --	1 ----	← 14.1.5 completes the picture with a morse code translator. Note that there are different versions of Morse Code, with the International being different from the American.
B ----	O - -	2 ----	
C - - -	P - - - -	3 - - - -	
D - - -	Q - - - -	4 - - - -	
E -	R - - -	5 - - - -	
F - - -	S - - -	6 - - - -	
G - - - -	T -	7 - - - -	
H - - - -	U - - -	8 - - - -	
I - -	V - - - -	9 - - - -	
J - - - -	W - - - -	0 - - - -	
K - - - -	X - - - -	& - - - -	
L - - -	Y - - - -	. - - - -	
M - - -	Z - - - -	, - - - -	

VectorStock®
VectorStock.com/21574501

The telegraph persisted into the 1950s, slowly being replaced by the telephone, which allowed people to talk to one another directly.

Several companies offered telegraph learner kits, such as the Premium Learner's Apparatus or the Champion Learner's Systems offered by Partrick and Carter. **14.1.6** and **14.1.7**.

PARTRICK & CARTER'S

PARTRICK & CARTER'S
PREMIUM LEARNERS' APPARATUS,
OR SHORT LINE INSTRUMENT.

Not the Cheapest, but Guaranteed the Best.

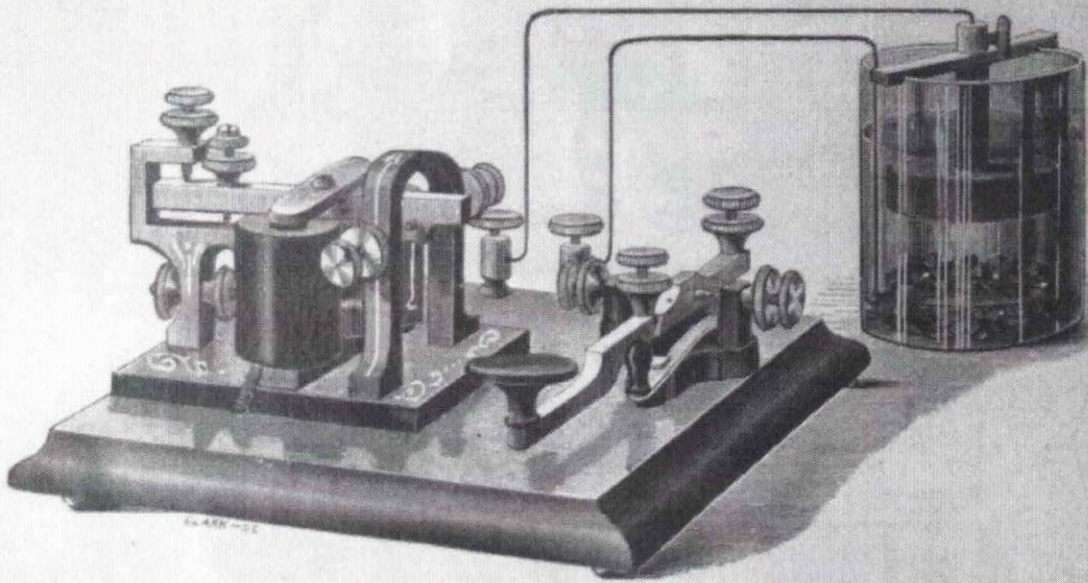

The Premium Learners' Apparatus and Outfit comprises the famous "NEW GIANT SOUNDER, PERFECTED," and the "NEW CURVED KEY," placed upon a polished walnut base, with a cell of Callaud Battery, Chemicals, Office Wire and an excellent Book of Instruction.

These Instruments are the exact style, size and form of the Instrument upon which we received the highest award at the Centennial Exhibition over all competitors. There is nothing whatsoever in miniature or half made up. Everything perfectly strong and reliable, and so guaranteed, or money refunded. Our Book of Instruction, which accompanies the Instrument, contains full and explicit instructions as to the manner of setting up the battery, running of wires, &c.

14.1.6↑

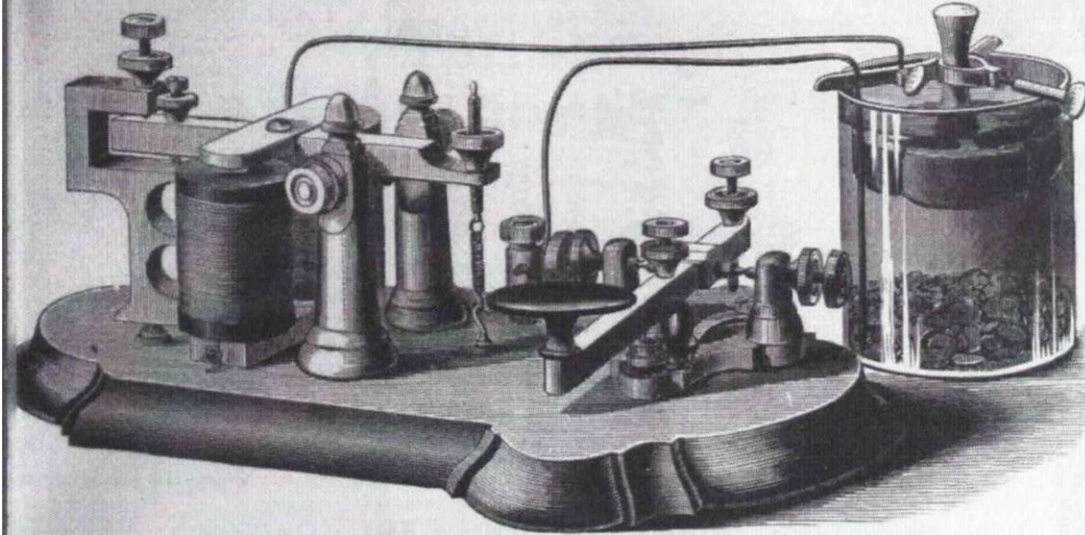

CHAMPION LEARNERS' INSTRUMENT.

NOTE.—Learners' Instruments, as sent out with Students' Outfit, are wound with the wire which gives the best result on a *very* short line with one cell of Battery. By adding two or three cells of Battery they may be worked on *metallic circuit* of half a mile or more; but when it is desired to operate through *one* wire and ground the fine wire instruments should be used. The Battery required will be about as follows: For half mile to one mile, with two instruments, 4 to 6 cells; two miles, 8 cells; five to ten miles, 10 to 12 cells. For each instrument added to the line add one cell of Battery.

None genuine without the name of **PARTRICK & CARTER**, Philadelphia, on the base—so beware of imitations.

14.1.7↑

Note the power necessary to send a telegram over various distances for the Champion system .

- ≤ 1 mile – 4 to 6 cells
- 1 to ≤ 2 miles – 8 cells
- 5 to ≤ 10 miles - 10 – 12 cells

Bunnell's Learners' Instrument Perfected.



Complete and Perfect, full-sized Sounder and Key, with Book of Instruction.
Battery, Wire, and all necessary Materials.

[These Instruments have been greatly improved in their working qualities and in the style in which they are finished. These having the latest improvement in their construction are those manufactured *only* by Messrs. L. G. TILLOTSON & CO. JESSE H. BUNNELL.]

They are made in the best manner, and are just exactly the thing wanted for
**LEARNERS' USES, FOR TELEGRAPH SCHOOLS, or FOR
SHORT LINES, from a few feet to 12 miles long.**

PRICE, Complete, with Battery, Book of Instructions, Wire, and all necessary materials to put in operation, singly	\$8 50
or on a short line.....	6 50
Learners' Instrument, without Battery, &c.....	7 50
Ornamental Learners' Instrument, Rubber Covered Coils, &c.....	
Same Instruments, wound with finer silk covered Wires, so as to operate satisfactorily lines up to twelve miles in length, \$1.00 in addition to above prices.	

A COPY OF SMITH'S MANUAL,
new and enlarged edition (see advertisement in another column) sent with each complete outfit of BUNNELL'S PERFECT
LEARNERS' INSTRUMENT.

These prices subject to our usual discount of 20 per cent. where money is sent in advance, either by Postal Order or
Draft.

L. G. TILLOTSON & CO.

Bunnell also offered a Learners system from L.G. Tillotson, **14.1.8**↑.



The quart size jar shown in **14.1.9** is typical of the battery jars used to power the telegraph.

←**14.1.9**

14.1.1 J.H. BUNNELL & Co. , BUNNELL TELEGRAPHIC & ELECTRICAL Co.

No discussion of the Telegraph would be complete without a discussion of Jesse H. Bunnell. Not only was he a major player in the early telegraph industry, but the history is so very interesting, as well.

Jesse was born in Ohio in 1843 and delivered telegraph messages at age 11. At 13 was a full-fledged telegraph operator. He set a world speed record of 32 words/minute (average) over two hours at age 17. When the Civil War erupted, he joined the Union Military Telegraph Service (UMTS), which had been organized by Andrew Carnegie, himself a telegraph operator at age 15. Starvation and exposure during McClellan's campaign of 1864 weakened him to the point of having to resign.

He partnered with James Partrick , successor to Chester, Partrick & Co. from 1864 – 1872. He worked for L.G. Tillotson from 1875 – 1878, before starting his own company, J.H. Bunnell & Co. He hired Charles McLaughlin as a partner in charge of sales, etc. so he could concentrate on new innovations and manufacturing of telegraphic supplies. He soon branched into a variety of electrical items, both as manufacturer, wholesaler and retailer. They produced fire alarm equipment, burglar alarms, security systems and medical equipment, including medical batteries. Jesse died in 1899 leaving uncertainty as to the future of J.H. Bunnell Co.

McLaughlin moved quickly to reassure their customers that the company was alive and well. In October of 1899 McLaughlin and four others filed to incorporate J.H. Bunnell & Co. in the state of N.Y. McLaughlin's move did not sit well with the Bunnell family, however. Although they had possession of Jesse's patent rights, they could not stop the surviving partner from continuing the business as J.H. Bunnell & Co. . Their response was to form their own company, in competition with J.H. Bunnell & Co. In January of 1900, the Bunnell Telegraphic and Electrical Co. was formed. Its major incorporators being Mary Bunnell, Jesse's widow, their son Dewitt and Son-in-Law, Albert Wise.

Competition was fierce between the two companies . The March 20, 1900 issue of The Telegraph Journal carried opposing, full page ads from the two companies.

J.H Bunnell & Co. claimed *“We own the Good-Will, Name, Copyrights, Trademarks and all the other assets of the old firm of J.H. Bunnell & Co. and propose to maintain our rights in the premises. Attention is called to these facts so that liability may not be incurred by dealing with unauthorized concerns.”*

The Bunnell Telegraphic and Electrical Co. read: *“Don't be misled by evasive statements and buy inferior goods purporting to be manufactured under our patents. All patents of Jesse H. Bunnell, deceased, are owned and retained by his estate. And we are the only firm authorized to manufacture thereunder.”*

The management team of J.H. Bunnell was experienced and solid, unlike the team of Bunnell Telegraphic and Electrical, which was young and relatively inexperienced. Dewitt, the General Manager of Bunnell Telegraphic & Electrical Co. died of Typhoid Fever in 1900, only months

after the company was formed. The two things the young company had, however, were plenty of capital and a skilled and experienced workforce at the manufacturing level.

Both companies expanded and increased production in 1901. J H. Bunnell, after a fire, built a larger factory in New York. Within a few weeks of its opening, The Bunnell Telegraphic & Electrical Co. announced the purchase of the entire business and factory of the National Electric Mfg. Co. in Milford, CT, which was already capable of producing district and fire alarm call boxes, etc.

In September of 1902 Albert Wise approached Charles McLaughlin with an offer to purchase his majority share of J.H. Bunnell & Co. Perhaps the timing was right; McLaughlin was 59 and had just lost his wife a few weeks earlier. He accepted the offer. By the middle of 1903, the two companies were merged, and McLaughlin retired. Wise was president and John Ghegan from J.H. Bunnell & Co. was, V.P and General Manager. Ghegan became president in December of 1903 when Wise died from complications following a trolley accident.

The competition between the two companies left an improved manufacturing base for J.H. Bunnell & Co., now with three factories. The Telegraph Age had this opinion of the new management team: *“These eminently practical men form probably the strongest combination ever established in this country for the manufacture of telegraphic apparatus.”*

It appears this opinion was largely based on the inclusion of an additional director. The announcement had read “The new officers, ‘together with Jesse H Bunnell’ constitute the Board of Directors.” It turns out that Jesse’s youngest son, Jesse H. Bunnell, Jr. who had been lost in obscurity, had been named to the Board. Only 22 years of age, at the time, he had already worked in the company’s factories for several years.

Unfortunately, the men of The Bunnell family were cursed with short lives. Jesse was taken ill on a train from California to New York in 1912. He died in a hospital in La Junta, Colorado at age 30. It turns out he had been experimenting with cocaine and opium while in California. He actually died of a drug overdose on that train.

The J.H. Bunnell & Co. continued to flourish, moving to Long Island in the 1930s, where it is still in business today.



←**14.1.1.1** is a battery jar embossed J.H. BUNNELL & Co. / N.Y. I wasn't sure where to put it, but as, I believe, J.H. Bunnell was strictly telegraph related, I placed it here. It is 4" in diameter x 8" tall, with a ground lip. It is circa 1875. The manufacturer is unknown, but I suspect Whitall Tatum.

14.2 TELEPHONE

A telephone is a device that permits two or more users to carry on a conversation when they are too far apart to be heard directly. In 1876, Alexander Graham Bell was the first to be granted a United States patent for a telephone

The essential elements of a telephone are a microphone (transmitter), earphone (receiver) which reproduces the voice at a distant location. Today, receivers and transmitters are usually built into a handset which is held up to the ear and mouth during conversation. It should be noted that early phones had separate microphones and receivers. The earliest phones had only a single device which served as both a transmitter and receiver.

The transmitter converts the sound waves to electrical signals which are sent through the system to the receiving telephone, which converts the signals into audible sound in the receiver. Telephones permit conversations in both directions simultaneously.

A power source was needed to transmit the audio over the wires to the person on the other end. In the early phones, "quart" sized battery jars, in the base of the phone, provided the power. See **14.2.1** and **14.2.2**, below.

14.2.1↓



14.2.2↓

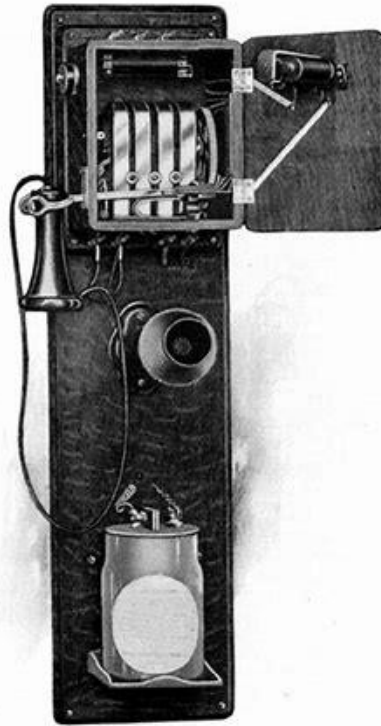

The receiver on an early phone hung on a hook on the side of the phone. Picking it up completed the circuit, with the power coming from the battery jars in the base of the phone. This alerted a person on the other end that you wanted to talk with them. Telephones were leased in pairs to a [subscriber](#), who had to arrange for a telegraph contractor to construct a line between them, for example, between a home and a shop. Users who wanted the ability to speak to several different locations would need to obtain and set up three or four pairs of telephones, one for each location .

Telephone Exchanges soon changed all that. In 1878 the first commercial telephone exchange was formed in New Haven, CT, with 21 subscribers. All calls were placed through a central office, where an operator placed the call for you. You used a magneto to alert the operator you wished to make a call. Turning the crank produced an alternating current (AC) at 50 – 100 volts, which rang a bell to alert the operator. The power was still generated at each individual phone with battery jars. Telephone battery jars were also of the quart size used in the telegraph.



14.2.3↑ shows a typical Telephone Exchange switchboard, where an operator connected phone calls from and to the subscribers.

As electrical power became more common, particularly in urban areas, the power source was at the Exchange offices and used by all subscribers.



Early telephones were locally powered, using either a dynamic transmitter (magneto) or by the powering of a transmitter with a local battery.

← **14.2.4** shows a Magneto cradle phone, from the 1880s.



←**14.2.5** shows a magneto wall phone. Turning the crank produced an alternating current (AC) at 50–100 V. This rang a bell to alert an operator at the local telephone exchange that you wished to make a call. With the exchange, you could use a single phone to speak with anyone who was a member of the exchange. Separate phones and lines were not needed.

14.2.6→ is a bottom view of a magneto that would have been used in such a phone.



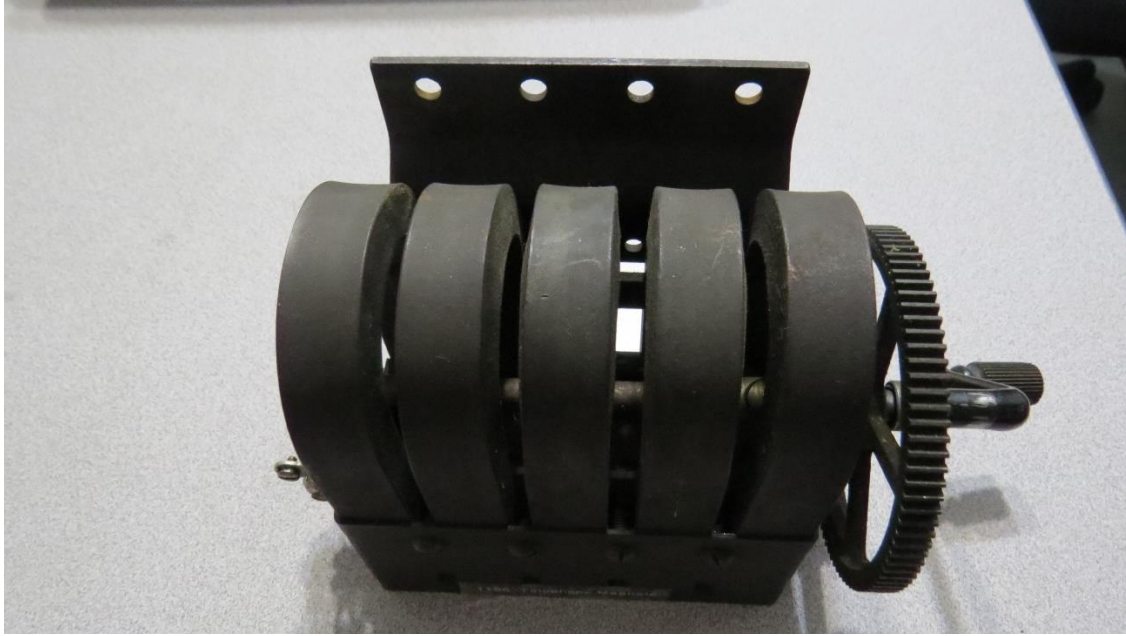

14.2.7↑ is the top view of magneto used in phones.

By around 1900, large racks of motor-generator sets in the telephone exchange building could supply this ringing current remotely instead and the local magneto was often no longer required,^[2] but their use continued into the mid-20th century, particularly in rural areas., where large power exchanges were not available. Some local farming communities that were not connected to the main networks set up barbed wire telephone lines that exploited the existing system of field fences to transmit the signal.

The following pictures (**14.2.8** through **14.2.11**) show the Timeline Evolution of the telephone. As time went on you can see how rapid the evolution became.

Telephone EVOLUTION



1876
Patent for Alexander
Graham Bell's phone

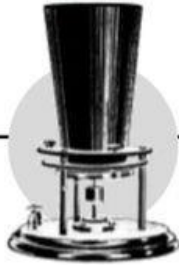

Late 1870s
Bell's original
phone



1880s
Hard crank wall
phone



1880s
Cradle phone

14.3.8↑

Prior to the hand crank phones of the 1880s, phones used battery jars to provide the necessary power.

Telephone EVOLUTION



1914
Candlestick
rotary phone



1920s
Desktop rotary
dial phone



1960s
Touch tone pad
phone



1970s
Wall touch tone
pad phone

14.3.9↑



1980s
Cordless phone



1988
Motorola bag
phone (with car
charger)



1994
First smartphone: IBM's
(SPC) Simon Personal
Communicator

14.3.10↑

**Telephone
EVOLUTION**



Mid-1990s
Analog mobile
phone

Late 1990s
Digital mobile
phones

14.3.11↑

15 STREET CARS / TROLLEYS

Even though electric vehicles (EVs) were not to be, at the time. Street Cars were a popular form of public transportation at the end of the 19TH and early 20TH Centuries.



As a bit of history. Street cars were originally horse drawn carriages, such as shown in **15.1**. They were later redesigned to the railcar design we're familiar with, in order to hold more people, but were still horse drawn. A re-design of the system led to tracks being installed on the streets to hold the steel wheels on the cars. This made it easier for the horses, as the cars rolled more smoothly.

15.1↑

The first electric streetcar systems appeared around 1890. By 1900 over 200 cities had electrical streetcar systems. By 1910 this had increased to approximately 500 cities.

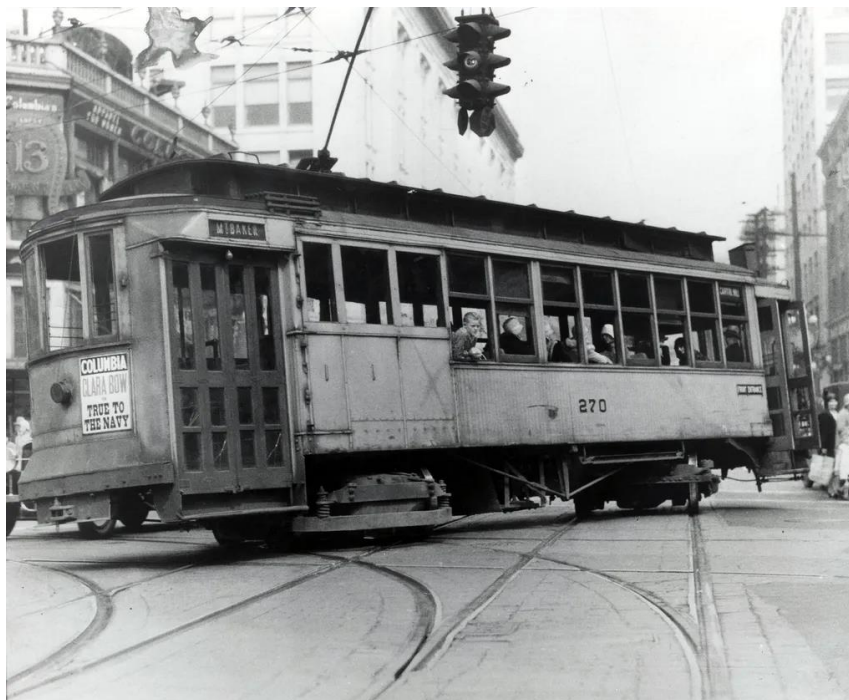

A typical electric streetcar from 1930 is pictured in ←**15.2**. Note that the car pictured is powered from an overhead electrified wire that ran above the street, over the car. A boom extending from the top of the car was in continuous contact with the wire.

THE ELECTRIC STORAGE BATTERY CO.

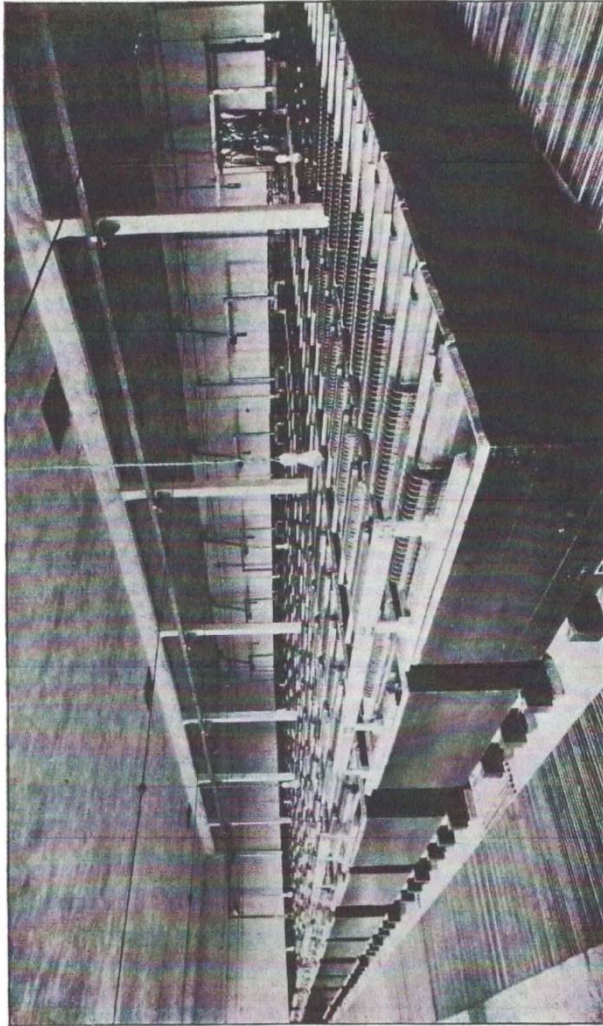

10

BUFFALO RAILWAY COMPANY

The Buffalo Railway Company operates three Batteries of "Chloride-Accumulators." The first was installed at Niagara Street, in April, 1898, and consisted of 270 cells, having a capacity of 1360 amperes. This was increased by the addition of plates in June, 1901, to the full capacity of the tanks and now has a capacity of 2480 amperes. The above photograph was taken before increase was made. In July, 1900, the Cold Springs Sub-Station was equipped with 280 cells, and in September, 1900, the Eagle Street Sub-Station with a similar number. The capacity of each of these Sub-Station Batteries is now 280 amperes.

←15.3 shows one of three installation in Buffalo, NY. It was installed in 1898. It consisted of 270 cells with a capacity of 2400 Amps.

The Electric Storage Battery Co. (E.S.B. Co.) of Philadelphia played a major role in supplying power for street cars. E.S.B. was founded by William Gibbs in 1888. Gibbs had previously purchased the ideas and patents of Invertoir Clement Payen, whose advances made the storage battery a commercial product. By December of 1894 Gibbs had all the patents and patent rights concerning the manufacture and use of electric storage batteries of the General Electric Co., The Edison Co., The Thomson-Houston, The Brush, The Accumulator Co, the Consolidated Electric Storage Company and the General Electric Launch Company. This gave ESB the sole right to supply this country with electric storage batteries of all the various types previously invented.

In appendix G, I have included a catalog from The ESB CO, from 1906. It gives you an idea of the size and numbers of battery jars required for such power stations.

Appendix H shows part of a presentation made by The ESB Co. at The Street Railway Conference in Detroit in 1902. It shows several of the ESB Power Plant installations providing power to Trolley cars at the time. 15.0.3 is part of that presentation. At the time of the presentation there were over 200 such installations across the country. By 1920 this had risen to approximately 500 installations.

The majority of the street cars received their power from an overhead electrical wire, which was powered from the electrical sub-stations, pictured previously. The car received the power from the wire via what is known as a Trolley Pole. A patent for such a device is included in the Patents chapter. Later versions used a third rail which supplied power. The earliest third rails were in a trench dug between the other two rails, with subsequent versions running adjacent to the other rails. In each case, contact had to be maintained with the car, in order to power it.



← 15.4 shows a Trolley pole for a streetcar that ran on metal tracks laid in the street. The single connection worked well, as the track provided grounding for the car.

15.5 → ran on rubber tires on ordinary streets. The second connection in such a system is actually grounding the system



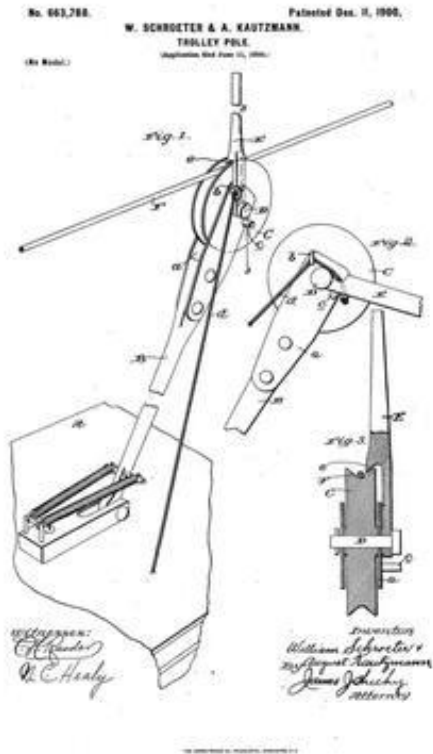

← **15.6** shows a typical pulley attachment for connection to the overhead wire.

15.7 ↓ is a close up of the pulley itself.



15.8 is an insulator system from a trolley, most likely used for overhead connections. Courtesy of Walt Baumgardt.



15.8↑

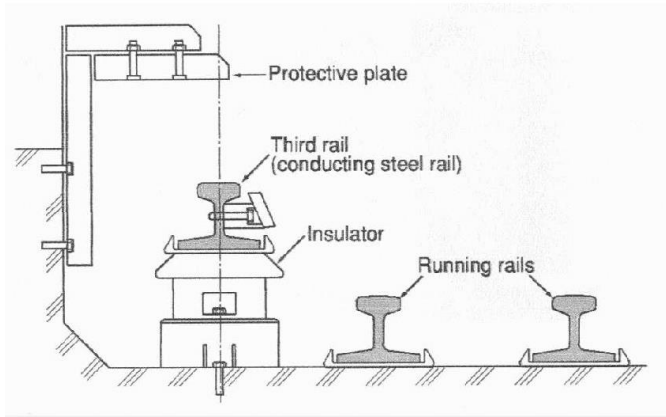

← **15.9** is a general schematic of a third rail configuration. It should be noted that some early trolley systems had the third rail running between the two running rails. A trailing wire connected to the rail through a slot in the pavement.

Third rail systems, of course, required insulators. **15.10** shows a typical third rail insulator. It is unmarked. Courtesy of Walt Baumgardt



←15.10

15.11↓ shows three different third rail configurations: Top, Side and Bottom Contact.

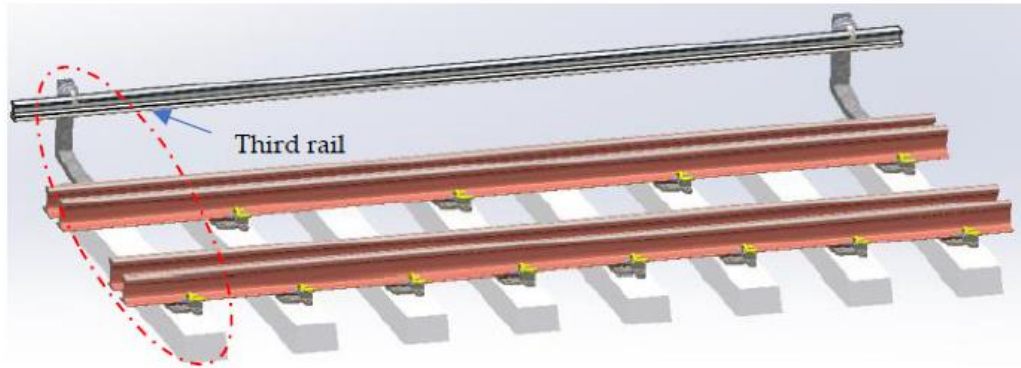

(a)

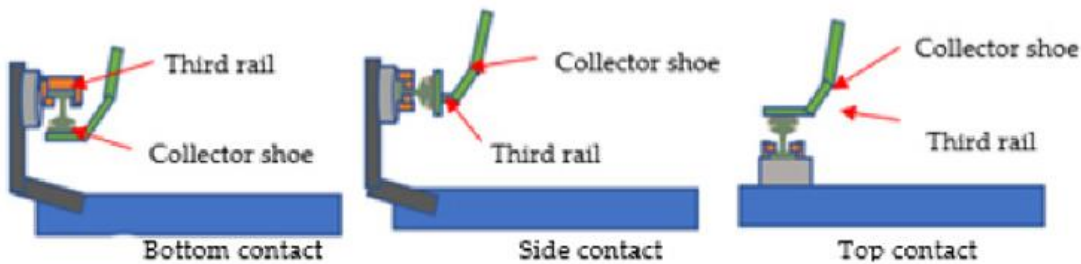

(b)

As you can see from the Pictures in Appendix H, the Streetcar powerhouse system dwarfed the Farm Battery Installation. Street cars required huge storage batteries to provide the constant power needed. Farm system requirements are small in comparison.

The company provided additional information stating that the 152 installations prior to Oct. 1, 1901 provided an aggregate of 98,000 KWH and the 220 installations prior to Oct. 1, 1902 provided an aggregate of 130,000 KWH.

By 1930 many of the street cars had disappeared. There are several reasons for the demise of the street cars (trolleys) during this period, many of them related to cost. Fares had initially been set at 5 cents, and many contracts stipulated that fare. In other cities, changing the fares required approval by local governments, none of which wanted to be the first to increase fares. Most of the cities had stipulated in the contracts that the streetcar companies were responsible for the maintenance of the streets around the tracks. The companies found themselves with no way to increase fares, while their maintenance costs were increasing. This was coupled with the fact that people wanted their own vehicles (cars). The decrease in riders further reduced revenue. Within a few years most of the streetcar companies were forced into bankruptcy.

In the early 1900s New York City had power stations all over the city to power the trolleys with the overhead DC system, before switching to the AC third rail system. Today Mayor DeBlasio Is proposing a new trolley system connecting Queens and Brooklyn. Scheduled for completion in 2024 and travelling a distance of 17 miles, it will be the first trolley in New York in over 100 years.

What might the world be like today, if Edison had been able to supply an automobile battery to Henry Ford, or if Henry Ford had not stipulated that it had to be an Edison Battery. Henry Ford is known to have terminated engineers who experimented with other than Edison battery. Would things have turned out differently if Edison had been able to provide a battery for Ford's Electric Vehicles?

Would the future of Electric, public transportation have turned out differently. Would the pressures of WWI still make the internal combustion engine the engine of choice at the time? We will likely never know the answer to that. Electric vehicles are currently being given a second chance. Time will tell what the future holds.

Other insulators known to have been used on trolley systems are:



15.12↑ SHOWS TWO OF THE FAMILIAR WOODEN INSULATORS USED IN SAN FRANCISCO AFTER THE EARTHQUAKE OF 1906.

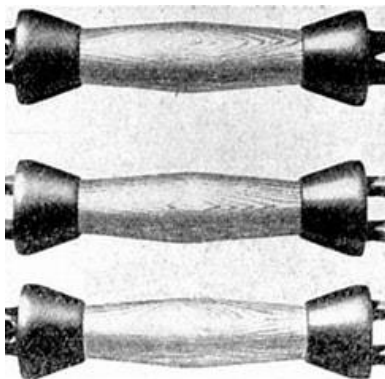

← **15.13** THESE FAMILIAR WOODEN STRAIN INSULATORS BY WESTINGHOUSE WERE ALSO USED ON TROLLEY SYSTEMS.

I would be remiss if I did not mention Granville T. Woods, one of America's most notable (and ironically) least known inventor. He has been called "The Black Edison," registering about 60 patents in his lifetime.

He was born in Columbus, OH in 1856, but lived most of his life in New York City. He died in 1910. He received his first patent in 1884, inventing 15 new technologies for electric railways, selling most of them to General Electric, Westinghouse and The Bell Telephone Co.

He invented a version of the electrical apparatus which gave the trolley its name. This apparatus, the "trawler" or "Trolley" is what provides electric traction power to the rail vehicle, transmitting power from the overhead catenary wire to the moving (or standing) vehicle.

He invented the Electric Railway Conduit System and the Third Rail. After the Blizzard of 1888, the Island of Manhattan banned all above ground, outdoor electrical wires of any kind. Mr. Wood converted the existing mechanical cable car system to electric traction, by removing the moving wire rope and pulleys and installing electrical contactor rails. This was the first system to use rails instead of wires, and the Third Rail Power Distribution system is still used by NYC subway system, Metro North and the Long Island Railroad today.

In 1885 he invented the "Telephony", which allowed telegraph stations to send messages both orally and via Morse Code, over the same line.

One of his greatest inventions was the Induction Telegraph System, 1887, which allowed messages to be sent to and from moving trains. This invention anticipated today's wireless LAN network. He also invented a system for the speed control of Trolleys and electric rail cars. Earlier systems had used resistors, which were inefficient and also produced a great deal of heat. The heat buildup was sufficient to cause wooden cars to spontaneously ignite. Wood's system used field shunting, in which the field coil in the motor would have a portion of its field coil added or removed thereby supplying the motor with more or less energy, allowing the car to accelerate, decelerate or maintain speed using a regenerative braking system.

16 RADIOS, PHONOGRAPHS, ETC.

16.1 Radios

Considering that in 1930, only 10% of rural America was electrified, a large portion of America still depended on battery jars for many of the things that we take for granted. This included

something as simple as the radio. Philco and other manufacturers offered what were called “farm radios,” designed to run on DC current, in addition to offering radios that ran on AC current. From the front they could look amazingly similar, yet the AC model plugged into a wall outlet, while the farm radio was hooked to battery jars. These 6-, 12- and 32-volt batteries were large, heavy and filled with sulfuric acid. They were generally kept in the cellar because of the smell. The three most common brands of farm radio were Zenith, Philco and Lafayette. They worked fine until the battery was depleted. This required owning a generator, which was prohibitive to cash-strapped farmers. An alternative was to take them to town to have them recharged, which took 2 or 3 days. Most farms of the day didn’t have automobiles. As the batteries required recharging, and were too heavy to transport, as most farms of the time did not have automobiles, an alternative was to purchase a gas-powered generator. Zenith offered a popular alternative, the “Zenith Wincharger,”(16.1) a small windmill.

You are invited To a Special
Showing of NEW ECONOMICAL

ZENITH

FARM RADIOS Operated by
Freepower from the air!

DeLUXE
 Wincharger

— And the Genuine
6-Volt DeLuxe

WINCHARGER
REG. U.S. PAT. OFF.

STOP Spending Money for
DRY BATTERIES!

•

END ALL Recharging
Nuisance!

•

ONLY 50c A YEAR
Power Operating Cost!

Complete with 6-foot propeller, air-cooled generator, auto-type brake, strong 5½-foot steel tower, and instrument panel.

SPECIAL PRICE
 Only
\$1500
 with new 6-Volt Zenith Farm Radio

← 16.1.1

The Wincharger was started in 1927 by the Albers Brothers in Iowa. It was an instant success for those that couldn’t afford back-up batteries. In 1935 Zenith purchased controlling interest. The line was expanded from the 6 volt system to include up to 110, producing anywhere from 110 – 2500 watts.

In the first 10 years of its existence, which includes the great depression, Wincharger sold 750,000 units.

The early “farm Radios” required three types of batteries: Type A, Type B and Type C. Type C batteries improved the sound quality, the need for which was soon engineered around; but this still left the Type A and B batteries.

The Type A batteries were low voltage, as low as 1.5 volts, to heat the filaments

inside the radio tubes.



They also had a line of Wincharger Farm batteries, which were designed to overcome most of the problems associated with other farm batteries. Their jars were larger to provide more room for sediment, reinforced plate support rods, and used Port Oxford Cedar separators. A complete Wincharger farm battery system was 32 Volts, containing 16 glass jar cells of 2 Volts each.

16.1.2 is such a Wincharger battery jar. It 9.5" 11" by 15.5" tall. It is embossed WATER LINE on 4 sides. The lid is embossed WINCHARGER / Do Not Lift Cell By Posts / Made in U.S.A. / Glass Guard.

The Type B batteries were higher voltage for the plate circuits of the radio. "B" batteries could be 22.5, 45, 67.5 or 90 volts.

16.1.3 (below) is an array of batteries made by Philco for powering radios. It contains 24 cells, each being 1.5" square x 6" tall. **Courtesy of Tommy Bolack.** **16.1.4** (below) is an individual jar from the array.



16.3 ↑



16.4 ↑



←**16.1.5** and **16.1.6**↑ are other Philco radio batteries. The dimensions of **16.5** are 4" x 6", at the base, x 10" tall. **16.5** looks more like a short, elongated fruit jar with dimensions of 3" x 6" X 5" tall, with a 2" diameter cap. Note the similarity of **16.1.6** to the battery jar from Osgood's Eureka Medical battery (**12.14.3**).



16.1.7↑



16.1.8↑

16.1.7 and 16.1.8 are PHILCO radio batteries measuring 2" x 6" x 8". Courtesy of Tommy Bolack

16.1.9 and 16.1.10 are Willard radio cells, likely from an array, below.



←16.1.9



16.1.10→



←**16.1.11**, a 24-cell array, radio battery by Willard. Each cell is 1.5" diameter x 5" tall., as seen in **16.1.10** and **16.1.11**.

Courtesy of Walt Baumgardt.



←**16.1.12** is an Edison Tube radio battery. It contains approximately 50 cells.



←**16.1.13** is reported to have been a radio battery. It is embossed EXIDE, with dimensions of 3" x 5" x 10" tall.



16.1.14↑



16.1.15↑

16.14 and **16.15**↑ show a Willard Model B, Battery Jar that was used to power radios in the early 19TH century. It is 1.5" diameter x 6.5" tall. It was used as part of an array, wired in series. A typical array to power radios is shown in **16.16**.

←16.1.16



Each cylindrical, glass cell is 1.25" diameter x 4.5" tall. They are arranged in a 4 x 6 cell array, connected in parallel to increase the voltage to approximately 48 volts. The jars are unmarked except for a number on the bottom. "WILLARD" is embossed on the connecting rods between the cells. The electrodes are 1" x 3". The box is embossed the same as 16.1.17 except for WTAM on one end. This was like an array used in conjunction with the WTAM radio station,



16.1.17↑ is a similar array with 1.5" square x 4.5" tall bottles. This box is embossed: (Front) THREAD RUBBER / WILLARD / Large W) INSULATION, (Left Side) WILLARD / 1126 (Right Side) WILLARD / 1126 (Rear) PART NO. 2776 / CHARGE at 1/10 AMP.
Courtesy of Walt Baumgardt.

The jar pictured below, **16.1.18**, is a battery for an early Radio. It is embossed PHILCOTRON B / PART K-483 on the front two lines near the top are the upper and lower liquid levels. It is 1.5” square x 6” tall. Note: This is seen in the advertisement on page 188. Courtesy of Walt Baumgardt. I have pictured the electrodes, **16.1.19**, separately. **Courtesy of Walt Baumgardt.**



← **16.1.18**



←**16.1.19**



← **16.1.20**

16.1.18 is similar to the K - 483. They show the Philcotron B, Part K 457. It, too, is 1.5” square but only 5” tall. Both were used in Rectifier cells such as seen in **16.1.1**.

The rectifier Cells were sold as “B” battery eliminators, which enabled one to power their radio from their home electricity through a wall socket.

16.1.1 FANSTEEL CORP.

Fansteel Corp of Chicago is listed as a manufacturer of specialty-metal products. It was formed in 1917 and survived into the 1990s. Carl A. Pfanstiel and James M Troxel started The Pfanstiel Electrical Laboratories in 1907. After WWI, due to feelings towards Germany and Germans, they became Fansteel Products Co. The name merely anglicizing the Dutch spelling.

In 1916 they hired Clarence Balke as Director of Research, who had spent years at the University of Chicago studying the rare-earth mineral, Tantalum. In 1920 they developed a Tantalum rectifier cell for radios, which proved to be immensely popular and profitable, although short lived. Marketed under the tradename “Balkite” they sold chargers and trickle chargers for Type “A” and Type “B” radio batteries, and eventually selling battery replacement units. By 1927, with the introduction of the AC tube, the boom was over. In those few years, however, they had immortalized the name in the history of radio. Forever a small company, they managed to survive into the 1990s.

16.1.1.1↓

16.1.1.2↓



16.1.1.3↓

16.1.1.4↓

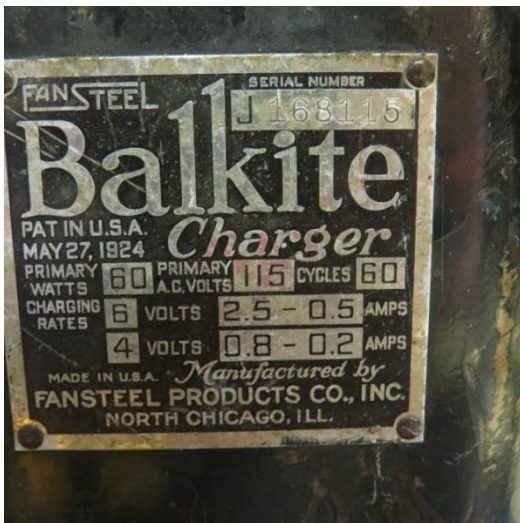

16.1.1. through 16.1.1.4, show Balkite Trickle charger for radios.

16.1.1.1 and 16.1.1.2 are Courtesy of Walt Baumgardt.

16.1.1.3 and 16.1.1.4 are Courtesy of Tommy Bolack.

They both ran on household AC current at the time, charging the batteries needed to power a radio. It wasn't until the AC tube was introduced in 1927 that a radio could run on ordinary household current.

Both are highlighted in the full-page ad in the November 1926 issue of "Radio Retailing". (See page 178).

Another Balkite advertisement, from the Music Trade Review of Sept. 3, 1927 is shown on page 179.

Page 180 is a review of one of the Balkite chargers, from The Wireless Engineer, April, 1925.

Based on what I've seen in my research, items such as these are in great demand by radio enthusiasts.



The New Balkite Charger
MODEL J. Has a low trickle charge rate and a high rate for rapid charging and heavy duty use. Can thus be used either as a trickle or as a high rate charger and combines their advantages. Noiseless. Large water capacity. Visible electrolyte level. Rates: with 6-volt battery, 2.5 and .5 amperes; with 4-volt battery, .9 and .2 amperes. Special model for 25-40 cycles. Price \$19.50. West of Rockies \$20. (In Canada \$27.50.)

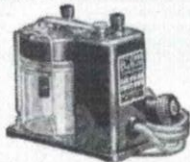

Balkite Trickle Charger
MODEL K. With 6-volt "A" batteries can be left on continuous or trickle charge thus automatically keeping the battery at fullpower. Converts the "A" battery into a light socket "A" power supply. With 4-volt batteries can be used as an intermittent charger. Or as a trickle charger if a resistance is added. Charging rate about .5 ampere. Over 200,000 in use. Price \$10. West of Rockies \$10.50. (In Canada \$15.)



A New Balkite "B" at \$27.50
 Balkite "B" eliminates "B" batteries and supplies "B" current from the light socket. Noiseless. Permanent. Employs no tubes and requires no replacements. Three new models. The new popular priced Balkite "B"-W at \$27.50 for sets of 5 tubes or less requiring 67 to 90 volts. Balkite "B"-X, for sets of 8 tubes or less; capacity 30 milliamperes at 135 volts—\$42. Balkite "B"-Y, for any radio set; capacity 40 milliamperes at 150 volts—\$69. (In Canada "B"-W \$39; "B"-X \$59.50; "B"-Y \$96.)



Balkite Combination
 Supplies automatic power to both "A" and "B" circuits. Controlled by the filament switch on the set. Entirely automatic in operation. Can be put either near the set or in a remote location. Will serve any set now using either 4 or 6-volt "A" batteries and requiring not more than 30 milliamperes at 135 volts of "B" current—practically all sets of up to 8 tubes. Price \$59.50. (In Canada \$83.)
 All Balkite Radio Power Units operate from 110-120 volts AC current with models for both 60 and 50 cycles. The new Balkite Charger is also made in a special model for 25-40 cycles.

No Balkite product has ever failed to be a best seller

The public is through with experiments, even in radio. It is turning as never before to standard nationally advertised lines which have proved themselves.

In the radio power field the standard line is Balkite. For no Balkite product has ever been offered to the public which has not been an outstanding success. No Balkite product has ever been put on the market which has not resulted in enormous volume and steady profit for both the radio dealer and jobber. The faith of the public in Balkite reliability and the Balkite trade mark is one of the finest tributes ever paid a manufacturer.

Balkite dominates the radio power field as never before. The Balkite Trickle Charger is easily the most popular charger on the market. Balkite "B" stands alone in a field only too crowded with experiments, as the "B" that has stood the test of time. The new Balkite Charger with both trickle and high charging rates, and the new Balkite Combination supplying all radio power automatically from the light socket, are selling faster than any new items ever introduced by Balkite. Balkite is backed by Balkite broadcasting and by one of the most powerful advertising campaigns in radio. These factors make Balkite one of the three or four best selling lines in radio today.

This is the greatest of all seasons for radio power devices. Make sure you get the maximum profit out of it by selling a line you know will stay sold, on which you know your profit will be clean. Turn it into the maximum profit by pushing Balkite.

FANSTEEL PRODUCTS COMPANY, Inc.
 North Chicago, Illinois

FANSTEEL
Balkite
Radio Power Units

Balkite has pioneered but not at the expense of the public or the radio trade



Balkite "AB" Contains no battery. A complete unit, replacing both "A" and "B" batteries and supplying "A" and "B" current directly from the light socket. Operates only while the set is in use. Two models: "AB" 6-135, * 135 volts "B" current, \$59.50. "AB" 6-180, 180 volts "B" current, \$67.50.



Balkite "A" Contains no battery. The same as Balkite "AB" above, but for the "A" circuit only. Will serve wherever 6-volt "A" batteries are now in use. Not a battery and charger but a perfected light socket "A" power supply. Price \$32.50.



Balkite "B" Has the longest life in radio. The accepted tried and proved light socket "B" power supply. 300,000 in use. The first Balkite "B," 5 years old, is still in service. Three models: "B" W, 67-90 volts, \$22.50; "B" 135, * 135 volts, \$32.50. "B" 180, 180-volts, \$39.50. Balkite now costs no more than the ordinary "B" eliminator.



Balkite Chargers Standard for "A" batteries. The standard charger for radio "A" batteries. Noiseless. Can be used during reception. Prices drastically reduced. Model "J,"* rates 2.5 and .5 amperes, for both rapid and trickle charging, \$17.50. Model "N" * Trickle Charger, rate .5 and .8 amperes, \$9.50. Model "K" Trickle Charger, the most popular of all chargers, \$7.50.

*Special Model for 25-40 cycles at slightly higher prices. Prices are slightly higher West of the Rockies and in Canada

First noiseless battery charging. Then successful light socket "B" power. Then trickle charging. And today, most important of all, Balkite "AB," replacing both "A" and "B" batteries and supplying radio power from the light socket. The great improvements in radio power have been made by Balkite.

This pioneering has been important. Yet alone it would never have made Balkite one of the best known names in radio—nor have made Balkite the leader in the radio power field.

Balkite has become the leader because over a period of years Balkite performance at the hands of its owners is unequalled in radio. Because with 2,000,000 units in the field Balkite has a record of freedom from trouble seldom equalled even in the oldest and most soundly established industries. Because Balkite Radio Power Units last longer than any other devices in radio. Because Balkite is today synonymous with quality.

Balkite has pioneered. But not at the expense of the public, nor of the radio trade. Balkite owners have been satisfied owners; Balkite dealers have

always made money. No Balkite product has ever failed to be a best seller.

The famous Balkite electrolytic principle

Balkite success has been based on the Balkite principle of electrolytic rectification. This principle is so reliable that it is today standard on the signal systems of most American as well as European and Oriental railroads. It is this principle that accounts for Balkite long-life, that makes Balkite radio power units permanent pieces of equipment.

Don't gamble with untried devices

Time was when one radio device looked as good as another. Today there is no longer any need for gambling with your own or your customer's money—you need no longer sell experiments. Balkite—the tried and reliable—offers you a complete line, to serve all requirements, at the lowest prices in Balkite history, backed by one of the largest advertising campaigns in radio. Concentrate on Balkite and make money.

FANSTEEL PRODUCTS CO., Inc., NORTH CHICAGO, ILL.

Balkite Radio Power Units

The Balkite Battery Charger.

621 : 354 : 3

MESSRS. BURNDIPT LTD. have submitted to us for test one of the "Balkite" Battery Chargers, for which they are agents in this country. Like many useful things, it hails from America, being manufactured by the Fansteel Products Co., Inc., of Chicago. The charger consists of a tantalum electrolytic rectifier with a small step-down transformer to enable it to be operated from the A.C. lighting mains. The whole is contained in a sheet-iron case with carrying handle, occupying a space of about 6½ in. by 6½ in. by 10 in.

The charger is supplied ready for use; it is only necessary to fill the cell with ordinary accumulator acid (sulphuric acid, Sp. Gr. 1.25), insert the plug-connector in a lighting socket and connect the output wires to the accumulator to be charged, taking care that the red-covered wire goes to the positive terminal and the black one to the negative terminal.

The printed instructions issued with the charger state that two tablespoonfuls of "Nujol" oil should be added to the rectifier cell to cover the acid, which should itself come within half an inch of the top of the cell. The purpose of the oil is presumably to arrest the escape of acid spray, but we have not found oil to be very satisfactory in its behaviour. A good deal of electrolysis takes place in the rectifier during operation, tending to make the oil froth excessively and even to overflow through the vent at the top of the cell. Even paraffin oil was found to froth considerably. It seems advisable, therefore, to use a very thin oil and very little of it, say about two teaspoonfuls or just enough to cover the surface of the acid.

The particular charger we have tested is rated to work off a 210-volt A.C. supply at 50 cycles and to charge a 6-volt accumulator at 2.5 amps. We find, however, that with an input of about 210 volts we scarcely obtain the rated output, and the current delivered to a 6-volt accumulator is only about 2 amps. Nevertheless, the charger does its work effectively and reliably without any noise. Accumulators have been left on charge overnight every night for several weeks, but the rectifier shows no signs of deterioration or change of any kind. It is of course necessary occasionally to add a little water to make up for the loss by electrolysis, as in the case of accumulators; the original acid should keep indefinitely.

As to constancy and efficiency, the Balkite rectifier is without many of the disadvantages of the old aluminium rectifier. For one thing, the sulphuric acid electrolyte has a very low resistance; and such troubles as creeping, crystallisation, precipitation or other deterioration are practically impossible. The potential drop across the rectifier cell appears to be quite low, and is certainly very much lower than is possible with an aluminium rectifier. Another important advantage of the low resistance electrolyte is the reduction of heating up during use. After an overnight run at 2-3 amps it becomes slightly warm. Warming up does not impair the working of a tantalum

rectifier, in fact it increases the current output somewhat. The power consumption from the mains is about 50 watts. A special replaceable fuse blowing at 4 amps is included in the D.C. output for safety.

With regard to the constructional details of the charger we have not much information, as everything is in a case which is not meant to be opened. The transformer has a centre-tapped secondary, as both halves of the cycle are rectified. There is only one cell, which we conclude contains a central lead electrode and two tantalum electrodes. Since this cell is made of a black opaque substance and has an opaque top sealed on, we have not been able to satisfy ourselves about the



The Balkite Battery Charger.

important question of the area of tantalum used; we imagine, however, that this is quite small.

In view of the simplicity of construction of the charger, the rather low D.C. current output, and the fact that no ammeter is provided, we feel that the price at present asked for the Balkite Battery Charger is rather high. Even the tantalum, which is certainly an expensive metal, is not enough to explain the cost.

With the small reservations indicated above, we consider the Balkite Charger a distinct success. Its ultimate value is of course bound up with the life of the tantalum, but as far as we can ascertain it should last for ever; time alone can decide this question definitely. This charging unit is probably as foolproof and yet effective as anything of its kind which has been put upon the market.

SWEDISH AMATEURS.

It is stated that the amateurs of Sweden are becoming more and more interested in transatlantic work. A cablegram was recently sent by *Radiobladet*, a leading Swedish wireless journal, to the American Radio Relay League, stating that the signals of sixty or more amateur stations in U.S. and Canada had been heard in Sweden by amateurs.

16.2 PHONOGRAPH BATTERIES, ETC.

16

**THE EDISON
Portable Phonograph
and
Gas Engine Battery.
TYPE "O."**

Price, complete, - \$20 00

Cost of Renewal Charge for
Complete Battery, \$2.80.

Itemized as Under:

4 Oxide Plates, Type "O," at 25c.	\$1.00
4 Zinc Plates, Type "O," at 25c.	1.00
4 Cans Potash, Type "O," at 17c. each.68
1 16-oz. Bottle Oil, at 12c.12
	\$2.80
Extra Flat Rubber Gaskets for Cover, 25c. each.	

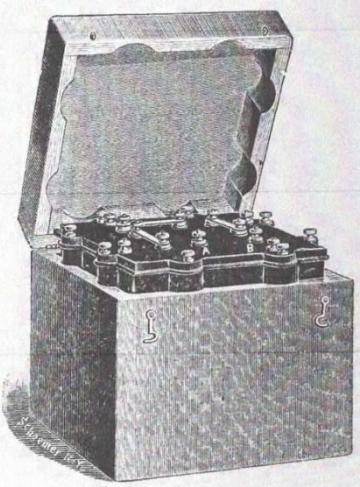

Size 9½ x 9½ x 9½ in.

This battery is specially designed for the use of traveling phonograph exhibitors, and will run a phonograph for 30 hours before needing any attention, after which it can be recharged at a small cost. It consists of a square hard-rubber cell divided into four compartments. The cover is bolted to the body of the cell by eight long brass bolts, and the cell is rendered air-tight by a flat rubber gasket that fits between the jar and the cover. It is encased in a polished oak box provided with a leather strap for carrying it easily.

←**16.2.1** is an Edison battery designed for travelling phonograph exhibitions. It is a cube, 9.5" on a side. It is hard rubber in an oak box.

16.2.2↓ is an Edison phonograph battery for exhibition use. It uses four Type "V" cells and is in an oak case with dimensions of 13" square x 9.5" tall.

EDISON EXHIBITION PHONOGRAPH BATTERY.

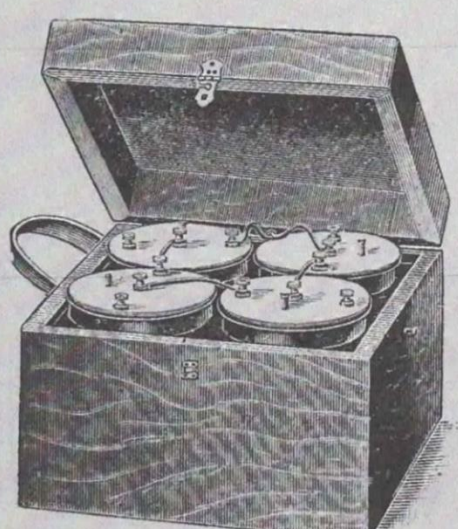

Consisting of 4 Liquid-Tight Steel Cells, Type "V," capacity 150 ampere-hours, in polished oak case, with strap for carrying same.

Price, Complete, = \$12.00

This battery will run the phonograph for 50 hours with single charge, and as it is absolutely liquid tight, it is specially recommended for travelling exhibition work.

Price of renewal parts for 4 "V" cells (see page 13), = = \$3.08.

Size, 13 x 13 x 9½ in.

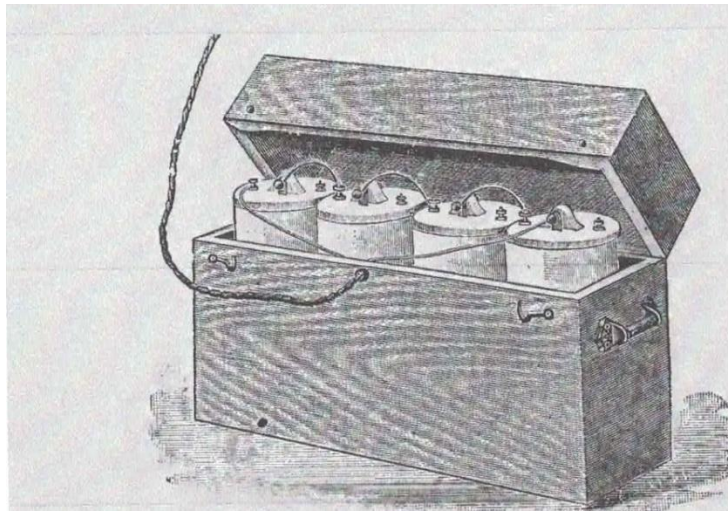

**The Edison
Phonograph . . .
Battery**
for
Stationary Work.

Consisting of four Edison-Lalande cells, Type "S" (300 ampere-hours), in lead-lined polished oak box, and battery cords, - \$15.00

This battery will run the phonograph for 100 hours with a single charge.

Price of renewal parts for four "S" cells, \$4.76

Size 25½ x 8 x 15 in.

16.2.3 ↑ is an Edison phonograph battery for stationary work. It uses four Type "S" cells and is also in an oak case, with dimensions of 25.5" x 8" x 15" tall. The "S" cell; is shown in **16.2.4**↓.

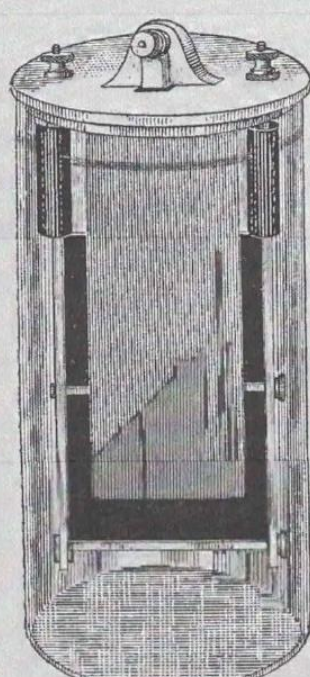

TYPE "S" CELL.
PHONOGRAPH AND FAN MOTOR MODEL.
Capacity, 300 Ampere-Hours.

Price Complete Cell, with
Porcelain Jar, = = = \$2.85

Price of Renewal Parts.

2 Zinc Plates (capacity 1 charge), 21c. each,	\$0.42
2 Copper Oxide Plates (capacity 1 charge), 25c. each,50
Can containing 1 charge Caustic Potash,28
Bottle Heavy Paraffine Oil, 1 ch'ge,	.05

For prices of permanent parts of cell see page 17.

Size over all 5¼ x 13 in.
Jar only, 5½ x 11 in.

18

**Edison 7-in. Iron-Clad Fan Motor Battery Outfit,
1898 Model.**

Consisting of Iron Clad Motor with 7 inch Fan and Guard, Battery Cords, three Edison-Lalande cells, Porcelain Jars, type "S," in polished oak box 18¾ inches long, 8 inches wide, 15 inches deep.

Outfit Complete, with charge to run motor 150 hours, \$17.50.

Edison Iron-Clad Battery Fan Motor, with 7-Inch Fan and Guard, \$8 50.

We wish to call your special attention to the following advantages in this motor, which are possessed by none other in the market.

It is noiseless, has self-oiling-bearings, and is entirely enclosed in iron-clad case, the rear end being left open for the regulation of brushes. The workmanship is of the very highest grade.

When ordering renewals for this Outfit always state for Type "S."

**Complete Renewals for 3 Cells, Type "S,"
\$3.60.**

—CONSISTING OF—

6 Zinc Plates, Type "S."
6 Copper Oxide Plates, Type "S."
3 Cans Caustic Potash, single charges, Type "S."
Bottle Heavy Paraffine Oil, sufficient for 3 cells.
BRUSHES FOR IRONCLAD MOTOR, EACH, 10c.

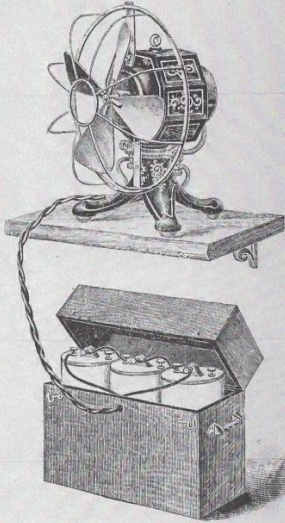

16.2.5↑

19

**Edison 9-inch Battery Fan Motor Outfit,
1898 Model. (Ball Bearing Motor.)**

Consisting of Edison Battery Motor with 9 inch Fan and Guard, Battery Cords, 4 Edison-Lalande cells, type "S," Porcelain Jars in polished oak box, 25 inches long, 8 inches wide, 15 inches high.

Outfit Complete, with charge to run motor upwards of 150 hours, \$25.00.

Edison Battery Motor, with 9-inch Fan and Guard \$12.00.

The motor belonging to this outfit is furnished with ball bearings; which materially decreases the frictional loss, and consequently the fan runs at a higher rate of speed while requiring considerably less current to drive it. This improvement increases the efficiency of the motor nearly 50 per cent.

The Motor with Fan occupies a space 19x12 inches. It is noiseless and the most efficient Battery Fan Motor on the market.

Flexible Battery Cord connecting Motor to Battery, \$1.00

**Complete Renewals for 4 Cells, Type "S,"
\$4.76.**

—CONSISTING OF—

8 Zinc Plates, Type "S."
8 Copper Oxide Plates, Type "S."
4 Cans Caustic Potash, single charge, Type "S."
Bottle Heavy Paraffine Oil, sufficient for 4 cells.
BRUSHES FOR EDISON 9 INCH MOTOR, EACH, 20c



16.2.6↑

16.3.5 and 16.3.6 are fan and battery units by Edison. 16.3.5 is three Edison-Lalande, Type "S" cells in an oak box with dimensions of 18,75" x 8" x 15" tall. 16.3.6 contains 4 Edison Lalande, Type "S" cells, also in an oak box with dimensions of 25" x 8" x 15" tall.



← 16.2.7 is the battery shown in 16.2.6.



(16.2.8 and 16.2.9 show Edison batteries designed for powering phonographs and fans. The “V” cell (16.9) is a steel enameled jar, likely of the “Gladstone” variety for more severe applications, while the “S” cell (16.2.8) is a plain porcelain jar.

17 ASSOCIATED EQUIPMENT

In addition to the battery jars, lids and electrodes, there were other items needed to set up and maintain batteries. I have used the term “associated equipment” to describe these items.

Below, **17.0.1**, is a picture of what Irons calls battery plate spacers, which he describes as a failed attempt to insulate the positive and negative plates from each other in a cell . Others, including the McDougalds, describe them as protective covers for the wires between batteries, to protect them from the corrosive materials dripping from batteries above, such as in a farm battery set up. They have been found in various shades of aqua, blue, and green. Courtesy: **Walt Baumgardt**



←17.1



←**17.2** is an automatic water fill unit to maintain the liquid level in the batteries. It is a quart size; 5.5” diameter x 3.5” high. The neck is 1.75” diameter x 1.5” high. Aqua in color it is embossed: **(F- Readable UD) PILOT CELL AUTOMATIC / WATER FILLER / STYLE A - ONE QUART / To Refill - Invert bottle and / Unscrew Goose Neck at Sleeve / THE ELECTRIC STORAGE BATTERY CO.** This is the courtesy of **W. Baumgardt**, who acquired it from **Phil Mayhew**.



←**17.3** is the complete assembly using the bottle from **17.2**. Notice: it includes the gooseneck mentioned in the embossing on the jar.



17.4 ↑



17.5 ↑



17.4 and **17.5** are jug type glass vessels, with spigots near the bottom, also from the Electric Storage Battery Co. **Courtesy of Tommy Bolack.**

17.6 is a one-gallon jug, inverted, to fit a holder. The base of the holder is embossed: (arc) **Utility Battery Filler / (arc) Pat's. Pend. / E. Edlmann & CO. Chicago U.S.A.** **Courtesy of Tommy Bolack.**

As **17.6** is labelled as to what it is, I assume they all served a similar purpose.

These are courtesy of **Tommy Bolack.**



←17.7 is picture of associated equipment, the courtesy of **Debbi Graham**. The hygrometer, laying across the bottom was used to check the specific gravity of the electrolyte solutions, critical to a properly functioning battery. The other three items were various instruments for checking the condition of the cells. In each case the contacts on the instruments were placed across the cell

(electrodes to check whether the battery was charged or spent, how many volts were left, etc. All instruments necessary to maintain a properly working battery.

Some manufacturers of square and rectangular battery jars made Battery Bridge Rests an integral part of the battery jar itself as seen in **17.8** and **17.9**, below. They were, however, also manufactured to be retrofitted to existing jars as seen in 6.3. From my research, however, it seems most battery jars did not use battery Bridge Rests., with the electrodes merely suspended from the bottom of the lid.

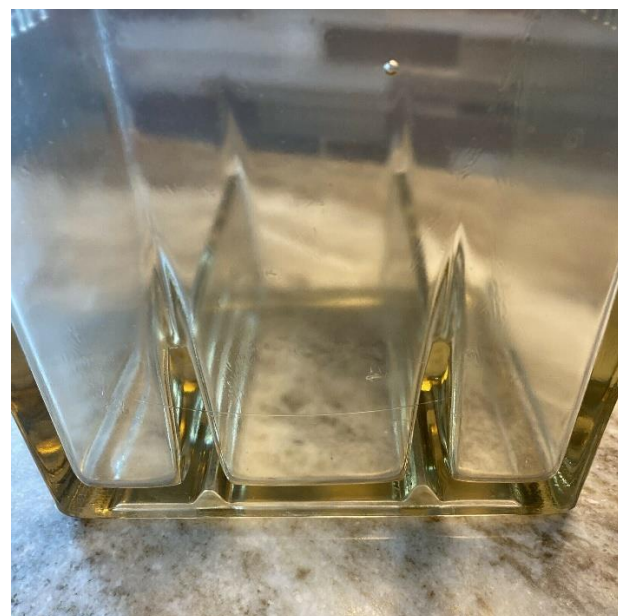
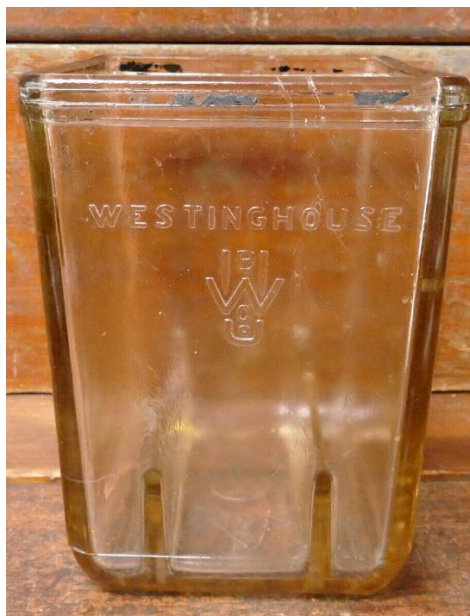

↑**17.0.7** Westinghouse jar with integral battery bridge rests.



↑ **17.0.8** Willard jar with integral battery
Bridge rests

←**17.10** shows battery bridge rests retrofitted to a flat bottomed battery jar.



←**17.11** shows various electrodes, leads etc. to accompany a medical battery. They accompanied the Gaiffe pocket medical battery.



17.12↑ and 17.13↑ Show an EXIDE, Two-Rate Charge Control Unit from , from The Electric Storage Battery Co. with the jar manufactured by Corning. The jar embossing is (arc) T.M. REG. / PYREX / (arc) U.S. PAT. OFF. The paper label reads: **EXIDE Two Rate Charge Control Unit / [TVR Voltage Relay Pat. No. 1960198 / Model 10 Serial No. 157 / 17°F. adjustment 13.7 volts for 6 cells / The Electric Storage Battery Co. / Philadelphia, PENNA U.S.A.**

A charge controller limits the rate at which a battery is charged and or drained, to protect against an overload condition. It prevents conditions that may reduce battery performance or cause a safety risk.

17.14↓

17.15↓



←17.16

17.14 through 17.16 show what appears to be a decorative brass battery jar holder, to disguise the battery jar for in those instances where it had to be in a public space. It appears to have been custom made to fit a specific jar.



←**17.17** is a carry handle for battery jars.
In this case it appears to be made
specifically for this particular jar.

17.1 BATTERY WATER AND ACID

It is natural that chemically pure water and sulfuric acid would be critical to the maintenance of a battery. The water had to be pure so as not to add unknown contaminants to the battery, which could damage it.



←17.1.1

I could find no information on the Campbell Bros. in Jamaica, NY. Obviously, they were a beverage company, among other things. There is a Campbell Construction Co. in Jamaica, NY. It could be part of the same company and even the same family.



17.1.2↑



17.1.3↑

17.1.2 and 17.1.3 show a Sulfuric Acid bottle from The Electric Auto Lite Co. of Toledo, OH. It was formed in the early 1900s to produce spark plugs, for which they are best known. Obviously, they supplied other battery products, as well, including Sulfuric Acid.

Auto Lite began in 1911, with the merger of two small companies producing buggy lamps. By the 1930s it was a major supplier of automotive parts. Its real history, however, began in 1935 with the introduction of the Auto Lite spark plug.



17.1.4↑



17.1.5↑

17.1.6↓



17.1.4 through 17.1.6 show Hydro Puroc water bottles.

The Charles E. Hires Co, of Philadelphia, famous for Hires Root Beer, also produced bottled water, including chemically pure Hydro Puroc for use in batteries.

Charles E. Hines was vacationing in New Jersey in 1875 when he was served a drink compounded from Sassafras root and herbs. Being a pharmacist, he experimented with Sassafras root and other ingredients. In 1876 he

introduced Hires Root Beer. At first, he sold packages of the dried roots, bark and herbs and people made their own. It became so popular that in 1890 The Charles E. Hires Company was formed .



←**17.1.7** is a distilled water bottle from the Shasta Water Co made for storage batteries. The Shasta Water bottles water from the foot of Mt. Shasta, California.



17.1.8 is a half-gallon jug for Zenith Double Distilled Battery Water. I could find no information on Zenith Battery Water. There is, however, a Zenith Battery Co., of more recent origin.

18 PATENTS

I have included a list of patents that pertain to the topics covered in this Volume. A similar list is included in Volume I for patents more directly related to battery Jars. I didn't include the patents themselves, as they are easily accessible online.

Inventor	Date Issued	Pat. No.	Title
L. Drescher	7/4/1871	116,695	Galvanic Faradic Machine
T.A. Edison	11/5/1872	142,999	Galvanic Battery
T.A. Edison	3/6/1883	273,492	Secondary Battery
Paul Seiler	12/12/1882	269,124	Automaqt5ic Telegraph Signal Box
Otto Flemming	6/23/1885	320,547	Medical Battery
L. Drescher	10/11/1885	168,560	Magneto Electric Machine
L. Drescher	10/12/1886	350,621	Galvanic Battery Cell
L. Drescher	11/2/1886	352,084	Medical Induction Coil (Pocket Battery)
L. Drescher	9/6/1887	369,505	Galvanic Cell
P.C. Burns	12/4/1888	393,814	Galvanic Battery
J.A. Barrett	5/14/1889	403,451	Electric Battery
J.A. Barrett	6/11/1889	415,196	Galvanic Battery
T.A. Edison	6/17/1890	430,279	Voltaic Battery
T.A. Edison	7/2/1889	430,279	Voltaic Battery
H.E. Waite	7/22/1890	432,081	Battery Cell
L. Drescher	9/4/1891	525,491	Electric Battery
P.C. Burns	12/4/1888	594,845	Electric Battery Ce4l
A.L. Werner	1/19/1897	575,449	Telegraph Battery Jar
L. Drescher	2/23/1904	753,051	Mechanical Toy
J.M. Barrett	11/10/1931	1,831,089	Power Plant Regulator
C.K. Bamber	123/1935	2,022,998	Battery Cell

BATTERY INSULATORS, OIL INSULATORS, AND CHLORIDE ACCUMULATORS
BY CHARLES & SANDI IRON

(Reproduced here with permission)



Battery Insulators,

From the first time that a cell or battery was used to supply electricity ... a way was needed to prevent or reduce the leakage of electric current. This leakage occurred when over the surface of the cell or battery (and the support that it was placed on) became coated with a fine deposit of acid-laden moisture and dust.

It was found that electric leakage was reduced if each cell or battery (a series of cells) was isolated from the support on which it sat.

Wood framing was used, but it was discovered that, over time, the wood would absorb the acid-laden moisture and created a direct path for electrical leakage, and eventually the acid moisture would cause the wood to rot.

Battery Insulators were used with DC electric systems as low as 1-2 volts and up to 600 volts and greater.

Lower DC voltage was used for a short time with telegraphs, alarms, and railroad signals. Higher voltage was used for lighting, motors, pumps, etc.

Originally, plain glass battery insulators were placed between wooden stringers and the battery tank. This proved to be *insufficient* ... so, glass insulators were added between the wood stringers and the floor. This combination became known as "Double Insulation." However, this did not prevent the decay of the wooden stringers ... so the Electric Storage Battery Company (E.S.B. Co.) designed and developed the combination of an oil insulator and an earthenware pedestal that solved the problem of the wood decaying. This earthenware pedestal / oil insulator became the standard for the industry and made it possible to finally do away with the wooden stringers.

In the display there is a COMPLETE Pedestal/Oil Insulator UNIT ... consisting of the cupped lead washer, alloy cap, Y lead washer, oil insulator, and the insulator pedestal. You can now see how the insulator and the pedestal look together. I believe that this is a one-of-a-kind ... COMPLETE UNIT. Also displayed is a copy of the patent for this invention that was granted to Cornelius Ambruster of Roslywn, Pennsylvania, on July 13, 1915.



The oil insulator / earthenware pedestal was used to support a battery tank that was constructed of wood and lined with lead. The exterior was coated

Oil Insulators, and Chlo

with asphaltum. Four to six CD-35s or CD-36s were used to support this style of Battery Tank (see Patent Sheet).

Please notice the base of the pedestal ... The uneven design at the base of the pedestal allowed water and foreign material to pass under the support when flushing the Battery Room Floor.

* * * * *

BIRDFEEDERS



The nickname "Birdfeeder" was given to the CD-35 and CD-36 around 1969. The collectors at that time thought they resembled a bird feeder. There are five of these displayed. These battery insulators were very unique because they used a nonconductive oil that was put in the circular trough and was then covered by a lead-alloy cap. The purpose of the cap was to exclude, as far as possible, all spray or other foreign matter from getting into the oil space and to protect it from being splashed when flushing the Battery Room Floor.

* * * * *

GLASS TRAY

The tray displayed is a No. 7 and it is embossed with "E.S.B. Co. No. 7 Made in U.S.A."

Jars that *were not sealed* were set on separate glass trays or boxes filled with sand. This was necessary due to the absence of a sealed cover which allowed acid-laden moisture to run down the outside of the jar and attack the wooden support (susceptible to rot) that the battery sat on.

* * * * *

GLASS THREAD SCREW BATTERY INSULATORS

This type of Battery Insulator has a very fragile Male Glass Thread Screw. It is believed that the thread was used to secure the insulator in the wooden stringers that supported the battery so that the insulator and support could be moved as a unit.



* * * * *

WHAT IS A WELL?

The wells (circular trough) that are a part of some of these insulators were used to collect Chlorides that would seep down the sides of the cell (battery jar). This type of battery insulator is known as a "Chloride Accumulator" and some are embossed with that information.

ide Accumulators

UNITED KINGDOM BATTERY INSULATORS

British Battery Insulators are different from Battery Insulators that were made in the United States.



The British Battery Insulators are in two parts ... a Base Unit and a Top. The smaller size bases have a round bump in the center that matches a depression in the top's center to locate and secure the two-pieces together.

Four two-part styles are known (of which two are in this exhibit). Until a year ago, the only colors known to exist in the two-part battery insulators were light green and light aqua.

Displayed is a CLEAR base battery insulator that is believed to be the only one known at this writing.

The only known light green "unipart" in the U.S.-style has a solid center instead of hollow center and has a corrugated base.

The style numbers and letters of the United Kingdom battery insulators were assigned by Ian Mackey. (These are not "officially" recognized numbers by the insulator-collecting community at this time.)

* * * * *

COLORS FOR BATTERY INSULATORS

COLORS of Battery Insulators range from various shades of • Aqua to Green • Clear • Smoke • Lavender • 7-up Green • Emerald Green • Yellow-Green • Cobalt Blue • Blue • Amber.

* * * * *

WHAT ARE GLASS BATTERY PLATE SPACERS?

It is believed that the "U" Shaped Glass Bars were part of a failed attempt to insulate the positive and negative plates from each other in a cell. At this writing, no proof has been found to support this theory.



The only reference found was to "Rods" being used in a patent issued to Stanley C.C. Currie of Philadelphia, PA, October 14, 1890, #438,532 ... "Insulated from one another by means of rods."

"Plate Spacers" have been found in various shades of aqua, blue, and green.

MANUFACTURERS

Some of the manufacturers known to have produced Battery (Rests) Insulators are: Brookfield Glass Company, Old Bridge, New Jersey; The Elmer Glass Co., Elmer, New Jersey; Hemingray Glass Co., Muncie, Indiana. Dumps that were used by these companies have been excavated by collectors. Battery Insulators, shards of, and warming pours of battery insulators were found at some of the manufacturer's dumps.

The following is a list of Battery Insulators (or pieces of such) that have been found in some of the Manufacturer's dumps.

Brookfield Dump – Old Bridge, New Jersey	
CD-20 Gould	CD-29 No Embossing
CD-53 U.S.L.	
Hemingray Dump – Muncie, Indiana	
CD-24 U.S. Light & Heating Co.	
CD-24 National Battery Co.	
CD-33 No Embossing	
Elmer Glass Co. Dump – Elmer, New Jersey	
CD-35 No Embossing	CD-36 E.S.B. Co.

* * * * *

EARLIEST PATENT DATE

The earliest known patent date for a Glass Battery Insulator is July 12, 1870. The patent number was 105,252 and was granted to Orris W. Robertson of Milwaukee, Wisconsin.

* * * * *

E.S.B. CO.

The Electric Storage Battery Co. (E.S.B.Co.) of Philadelphia, Pennsylvania, was founded in 1888 by W. W. Gibbs, and by 1908 they were using glass for their battery (rests) insulators.

This information is supported by copies of various patents that accompany this display.

* * * * *

GOULD

Gould Storage Battery Co. was founded in 1898 by Charles Gould of New York, and they applied for their first patent for a Battery Insulator in 1913.

U.S.L.

In 1898 the National Battery Company was formed. Electric Autolite later gained control of National Battery Company and operated it under the name of U.S.L. Battery Company.



* * * * *

NO WRITTEN HISTORY

The collecting of "Battery (Rests) Insulators" is a specialty within the hobby of Insulator Collecting. Although we are learning more about how the Battery Insulators were used and who made them, the history of the Battery Insulators has yet to be written.

We need more written documentation.

At this time there are still unlisted colors and styles just waiting to be discovered.

* * * * *

AS COLLECTORS OUR GOAL ... We hope that by viewing this display you will become more aware of the different styles (CD numbers) and the range of colors ... as well as some basic history of the Battery Insulators, Oil Insulators, and Chloride Accumulators.

CHARLES AND SANDI IRONS - 2005

SOURCES:

History & Guide to North American Insulators,
.....John and Carol McDougald
Gould Electronics Inc.Judy Kokal
EnerSys (Exide).....Deb Burkhart
Patent InformationGlenn Drummond
American/British Battery
Rest Gallery websiteIan Mackey
Patent InformationElton Gish
Storage BatteriesE. W. Allen
NIA (National Insulator Association)web site
ResearchSmithsonian Institute, Washington, D.C.
ICONBill Meiers
Hemingray Dump InfoDarin Cochran
Hemingray Dump InfoBob Stahr
Brookfield Dump InfoDavid Sztramski

**BATTERY INSULATORS, OIL INSULATORS
and CHLORIDE ACCUMULATORS**



Figure 2: "Birdfeeder" battery insulator.



Figure 4: USL No 2, light aqua

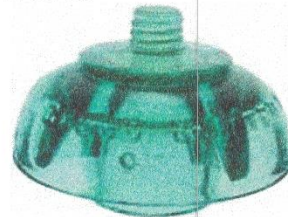

Figure 6: Gould Battery (R)
Patented Dec. 1. 1896, light green



Figure 7a: Chloride Accumulator /
The E.S.B. Co., aqua



Figure 7b: Chloride Accumulator /
The E.S.B. Co., battery rest, green.



Figure 9: CD-29
no embossing, light-green



Figure 10: CD-20
E.S.B. Co.



Figure 11: CD-24 embossed The
United States Light & Heating Company, aqua



Figure 12: CD-30 embossed
Chloride Accumulator / The E.S.B. Co.,
emerald green



Figure 13: CD-22.5 embossed: (F) Gould
Battery (R) Pat. Dec.1.1896, yellow-green



Figure 15: A CD-22 with no embossing in
deep violet cobalt blue.



Figure 16: CD-40 with no embossing in
dark aqua.

This article is reproduced with permission of the authors.

By Charles and Sandra Irons, Milford, Delaware

First Place - Writer's Choice Contest - Research Info
The Delmarva Blowpipe newsletter; Delmarva Antique Bottle Club

From the first time that a cell or battery was used to supply electricity, a way was needed to prevent or reduce the leakage of electric current. This leakage occurred when the surface of the cell or battery (and the support that it was placed on) became coated with a fine deposit of acid-laden moisture and dust.

It was found that electric leakage was reduced if each cell or battery (a series of cells) was isolated from the support on which it sat.

Wood framing was used, but it was discovered that over time the wood would absorb the acid-laden moisture. This created a direct path for electrical leakage and eventually the acid moisture would cause the wood to rot.

Battery insulators were used with DC electric systems as low as 1-2 volts and up to 600 volts and greater.

Lower DC voltage was used for a short time with telegraphs, alarms, and railroad signals. Higher voltage was used for lighting, motors, pumps, etc. Originally, plain glass battery insulators were placed between wooden stringers and the battery tank. This proved to be insufficient ... so, glass insulators were added between the wood stringers and the floor. This combination became known as "Double Insulation."

However, this did not prevent the decay of the wooden stringers, so the Electric Storage Battery Company (E.S.B. Co.) designed and developed the combination of an oil insulator and an earthenware pedestal that solved the problem of the wood decaying. This earthenware pedestal / oil insulator became the standard for the industry and made it possible to finally do away with the wooden stringers.



Figure 3: Glass tray.

Illustrated on the right [Figure 1] is a complete Pedestal / Oil Insulator unit consisting of the cupped lead washer, alloy cap, Y lead washer, oil insulator and the insulator pedestal. It can be seen how the insulator and the pedestal lock together. It is believed that this is a one-of-a-kind, complete unit. The patent for this invention that was granted to Cornelius Ambruster of Roslywn, Pennsylvania on July 13, 1915.

The oil insulator / earthenware pedestal was used to support a battery tank with lead. The exterior was coated with asphaltum. Four to six CD-35s or CD-36s were used to support this style of battery tank.

Please notice the base of the pedestal. The uneven design of the base of the pedestal allowed water and foreign material to pass under the support when flushing the battery room floor.

Birdfeeders

The nickname "birdfeeder" was given to the CD-35 and CD 36 around 1969. The collectors at that time thought they resembled a bird feeder. There is an example of an aqua CD-36 embossed "The E.S.B. Co. (R) Made in U.S.A. B-15993-3" illustrated on the right [Figure 2].

These battery insulators were very unique because they used a nonconductive oil that was put in the circular trough and was then covered by a lead-alloy cap. The purpose of the cap was to exclude, as far as possible, all spray or other foreign matter from getting into the oil space and to protect it from being splashed when flushing the Battery Room floor.

Glass Tray

Jars that were not sealed were set



Figure 5: Gould Battery (R)
Patented Dec. 1, 1896, aqua

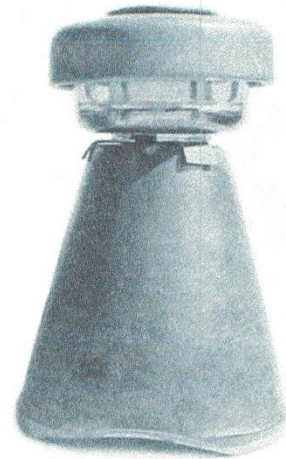

Figure 1: Pedestal oil insulator.

on separate glass trays [Figure 3] or boxes filled with sand. This was necessary due to the absence of a sealed cover which allowed acid-laden moisture to run down the outside of the jar and attack the wooden support (susceptible to rot) that the battery sat on.

Glass Thread Screw Battery Insulators

This type of Battery Insulator has a very fragile male glass thread screw. It is believed that the thread was used to secure the insulator in the wooden stringers that supported the battery so that the insulator and support could be moved as a unit. Several are illustrated [Figures 4-6].

What Is A Well?

The wells (circular trough) that are a part of some of these insulators were used to collect Chlorides that would seep down the sides of the cell (battery jar). This type of battery insulator is known as a "Chloride Accumulator" and some are embossed with that information [Figure 7a and b].

United Kingdom Battery Insulators

British battery insulators are different from battery insulators that were made in the United States.

The British battery insulators are in two parts: a base unit and a top. The smaller size bases have a round bump in the center that matches a depression in the top's center to locate and secure the two pieces together.

Four two-part styles are known. Until

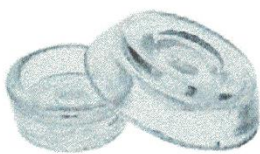

Figure 8 British battery insulators are in two parts.

a year ago, the only colors known to exist in the in the two-part battery insulators were light green and light aqua. Illustrated [Figure 8] is a clear base battery insulator that is believed to be the only one known at this writing.

The only known light-green "unipart" in the U.S.-style has a solid center instead of hollow center and has a corrugated base.

The style numbers and letters of the United Kingdom battery insulators were assigned by Ian Mackey and are not "officially" recognized numbers by the insulator-collecting community at this time.

Colors for Battery Insulators

Colors of battery insulators range from various shades of aqua to green, clear, smoke, lavender, 7-Up green, emerald green, yellow-green, cobalt blue, blue and amber.

What Are Glass Battery Plate Spacers?

It is believed that the "U" shaped glass bars were part of a failed attempt to insulate the positive and negative plates from each other in a cell.

At this writing, no proof has been found to support this theory.

The only reference found was to "rods" being used in a patent issued to Stanley C.C. Currie of Philadelphia, Pa., October 14, 1890, #438,532... "insulated from one another by means of rods."

"Plate spacers" have been found in various shades of aqua, blue and green.

Manufacturers

Some of the manufacturers known to have produced battery (rests) insulators are: Brookfield Glass Company, Old Bridge, New Jersey; The Elmer Glass Co., Elmer, New Jersey; Hemingray Glass Co., Muncie, Indiana.

Dumps that were used by these companies have been excavated by collectors. Battery insulators, shards of, and warming pours of battery insulators were found at some of the manufacturer's dumps.

The following is a list of battery insulator (or pieces of such) that have been found in some of the manufacturer's dumps:

Brookfield Dump - Old Bridge, New Jersey: CD-20, Gould; CD-29, no embossing [Figure 9]; CD-53, U.S.L. [Figure 4]

Hemingray Dump - Muncie, Indiana: CD-24, U.S. Light & Heating Co. [Figure 11]; CD-24, National Battery Co.; CD-33, no embossing

Elmer Glass Co. Dump - Elmer, New Jersey: CD-35, no embossing; CD-36, E.S.B. Co. [Figure 2]

Earliest Patent Date

The earliest known patent date for a glass battery insulator is July 12, 1870. The patent number 105,252 was granted to Orris W. Robertson of Milwaukee, Wisconsin.

The E.S.B. Co.

The Electric Storage Battery Co. (E.S.B. Co.) of Philadelphia, Pennsylvania was founded in 1888 by W.W. Gibbs. By 1908 they were using glass for their battery (rests) insulators.

The information is supported by copies of various patents.

Figure 10 illustrates an E.S.B. Co. CD-20 in aqua. Figure 12 is an emerald green example CD-30 embossed "Chloride Accumulator / The E.S.B. Co."

Gould

Gould Storage Battery Co. was founded in 1898 by Charles Gould of New York. Their first patent for a battery insulator is 1913.

Figures 5 and 6 illustrate two Gould insulators. Figure 13 is a beautiful example of a yellow-green CD-22.5 patented Dec. 1, 1896 while Figure 14 features another CD-22.5 in light lavender.



Figure 14: Another CD-22.5, this one light lavender in color.

U.S.L.

In 1898 the National Battery Company was formed. Electric Autolite later gained control of National Battery Company and operated it under the name of U.S.L. Battery Company.

Figure 4 illustrates an example of a U.S.L. CD-53 insulator in light aqua.

No Written History

The collecting of "battery (rests) insulators" is a specialty within the hobby of insulator collecting. Although we are learning more about how the battery insulators were used and who made them, the history of the battery insulators has yet to be written. More written documentation is needed.

At this time, there are still unlisted styles with no history [Figures 15 and 16] and others just waiting to be discovered.

As Collectors, Our Goal

Hopes are that as you read this article you will become more aware of the different styles (CD numbers) and the range of colors, as well as some basic history of the battery insulators, oil insulators and chloride accumulators.

Resources:

John and Carol McDougald, *History & Guide to North American Insulators*.

Judy Kokal, Gould Electronics Inc.

Deb Burkhart, EnerSys (Exide).

Glenn Drummond, patent information.

Ian Mackey, American / British Battery Rest Gallery website.

Elton Gish, patent information.

E.W. Allen, storage batteries.

NIA (National Insulator Association) website.

Smithsonian Institute, Washington, D.C., research.

Bill Meier, ICON.

Dann Cochran, Hemingray dump info.

Bob Stahr, Hemingray dump info.

David Sztramski, Brookfield dump info.



This article came from a brochure created as part of Charles and Sandi's display of battery insulators, oil insulators and chloride accumulators that won three awards: Best of Show, Most Educational and People's Choice during the Lewes, Delaware show in Sept., 2005.



Figure 8 British battery insulators are in two parts.

a year ago, the only colors known to exist in the in the two-part battery insulators were light green and light aqua. Illustrated [Figure 8] is a clear base battery insulator that is believed to be the only one known at this writing.

The only known light-green "unipart" in the U.S.-style has a solid center instead of hollow center and has a corrugated base.

The style numbers and letters of the United Kingdom battery insulators were assigned by Ian Mackey and are not "officially" recognized numbers by the insulator-collecting community at this time.

Colors for Battery Insulators

Colors of battery insulators range from various shades of aqua to green, clear, smoke, lavender, 7-Up green, emerald green, yellow-green, cobalt blue, blue and amber.

What Are Glass Battery Plate Spacers?

It is believed that the "U" shaped glass bars were part of a failed attempt to insulate the positive and negative plates from each other in a cell.

At this writing, no proof has been found to support this theory.

The only reference found was to "rods" being used in a patent issued to Stanley C.C. Currie of Philadelphia, Pa., October 14, 1890, #438,532... "insulated from one another by means of rods."

"Plate spacers" have been found in various shades of aqua, blue and green.

Manufacturers

Some of the manufacturers known to have produced battery (rests) insulators are: Brookfield Glass Company, Old Bridge, New Jersey; The Elmer Glass Co., Elmer, New Jersey; Hemingray Glass Co., Muncie, Indiana.

Dumps that were used by these companies have been excavated by collectors. Battery insulators, shards of, and warming pours of battery insulators were found at some of the manufacturer's dumps.

The following is a list of battery insulator (or pieces of such) that have been found in some of the manufacturer's dumps:

Brookfield Dump - Old Bridge, New Jersey: CD-20, Gould; CD-29, no embossing [Figure 9]; CD-53, U.S.L. [Figure 4]

Hemingray Dump - Muncie, Indiana: CD-24, U.S. Light & Heating Co. [Figure 11]; CD-24, National Battery Co.; CD-33, no embossing

Elmer Glass Co. Dump - Elmer, New Jersey: CD-35, no embossing; CD-36, E.S.B. Co. [Figure 2]

Earliest Patent Date

The earliest known patent date for a glass battery insulator is July 12, 1870. The patent number 105,252 was granted to Orris W. Robertson of Milwaukee, Wisconsin.

The E.S.B. Co.

The Electric Storage Battery Co. (E.S.B. Co.) of Philadelphia, Pennsylvania was founded in 1888 by W.W. Gibbs. By 1908 they were using glass for their battery (rests) insulators.

The information is supported by copies of various patents.

Figure 10 illustrates an E.S.B. Co. CD-20 in aqua. Figure 12 is an emerald green example CD-30 embossed "Chloride Accumulator / The E.S.B. Co."

Gould

Gould Storage Battery Co. was founded in 1898 by Charles Gould of New York. Their first patent for a battery insulator is 1913.

Figures 5 and 6 illustrate two Gould insulators. Figure 13 is a beautiful example of a yellow-green CD-22.5 patented Dec. 1, 1896 while Figure 14 features another CD-22.5 in light lavender.



Figure 14: Another CD-22.5, this one light lavender in color.

U.S.L.

In 1898 the National Battery Company was formed. Electric Autolite later gained control of National Battery Company and operated it under the name of U.S.L. Battery Company.

Figure 4 illustrates an example of a U.S.L. CD-53 insulator in light aqua.

No Written History

The collecting of "battery (rests) insulators" is a specialty within the hobby of insulator collecting. Although we are learning more about how the battery insulators were used and who made them, the history of the battery insulators has yet to be written. More written documentation is needed.

At this time, there are still unlisted styles with no history [Figures 15 and 16] and others just waiting to be discovered.

As Collectors, Our Goal

Hopes are that as you read this article you will become more aware of the different styles (CD numbers) and the range of colors, as well as some basic history of the battery insulators, oil insulators and chloride accumulators.

Resources:

John and Carol McDougald, *History & Guide to North American Insulators*.

Judy Kokal, Gould Electronics Inc.

Deb Burkhart, EnerSys (Exide).

Glenn Drummond, patent information.

Ian Mackey, American / British Battery Rest Gallery website.

Elton Gish, patent information.

E.W. Allen, storage batteries.

NIA (National Insulator Association) website.

Smithsonian Institute, Washington, D.C., research.

Bill Meier, ICON.

Dann Cochran, Hemingray dump info.

Bob Stahr, Hemingray dump info.

David Sztramski, Brookfield dump info.



This article came from a brochure created as part of Charles and Sandi's display of battery insulators, oil insulators and chloride accumulators that won three awards: Best of Show, Most Educational and People's Choice during the Lewes, Delaware show in Sept., 2005.

21 APPENDIX C GAMEWELL BATTERY SUPPORT INSULATOR

[R=∞ Home](#)

This odd little 2-part porcelain insulator has popped up many times over the past 50 years and continues to raise curious questions. We have never addressed it before so it is time we lay out what little information we know about it.



Typical Gamewell insulator.

Little was known about these little two-part insulators. According to Gerald Brown's books, someone told him they held glass rods in the grooves to support batteries for Gamewell Fire Alarm Telegraph Co. systems in banks. Several years ago, I did an exhaustive internet search on Gamewell and could not learn anything about the support for the batteries, but Steve Coffman was able to find a couple of references recently that confirmed how the insulators were used. One article described a Gamewell system installed in East Watertown, MA in 1906 for the Fire

and Police Departments. The article in the April 14, 1917, issue of Electrical Review and Western Electrician gave this detailed account of the battery room in the Holyoke, MA Central Fire-Alarm Office:

The battery room at the rear of the central office contains three rows of five shelves, each of insulated metal battery racks with capacity for 500 storage cells of the couple type. These are connected on the A and B banks. The couples are mounted in glass jars on glass rods and porcelain insulators. Each set of batteries on each circuit is protected by three-ampere cartridge fuses. The batteries are connected to the storage-battery switchboard through wires concealed in the ducts, which enter floor boxes under each post. The wires enter the pipe posts from below and connect to the fuse blocks.

A private-branch-exchange telephone switchboard with 10 auxiliary lines to official and engine-house instruments is used for fire-department calls. It is also connected with the New England Telephone Company's system by three trunk lines for public calls.

The complete system was installed by the Gamewell Fire Alarm Telegraph Company, of New York, under the direction of A. D. Wheeler, its New England agent. The installation work was done by E. P. Cochrane and G. A. Broder, construction engineers for Gamewell Company.

The batteries were used to maintain current in order to send a telegraph alarm message to the fire or police departments. There are grooves in the bottom of Gamewell glass battery jars to secure them on the glass rods supported by the little porcelain insulators. Apparently, the plug-bottom of the insulators fit in holes in metal battery support racks. The Watertown article stated the storage batteries were “*mounted on iron pipe racks with porcelain insulators and glass rods.*”



Gamewell glass battery jar with grooves in bottom.

Some of the insulators were originally found in a bank in Georgia or somewhere in the South. At least one insulator has been reported that was embossed on the bottom part: GAMEWELL 60. Here is a photo of the separate parts of the 2-part Gamewell insulator.



The head on the right is very different and requires a slotted type of base that I do not have. Perhaps it is an early version that fits in the iron pipe.



Typical Gamewell insulator with rare embossing: **GAMEWELL 60**

[R=∞ Home](#)

In the words of Elton Gish “This odd little 2-part porcelain insulator has popped up many times over the past 50 years and continues to raise curious questions. We have never addressed it before, so it is time we lay out what little information we know about it.”



Typical Gamewell insulator.

Little was known about these little two-part insulators. According to Gerald Brown's books, someone told him they held glass rods in the grooves to support batteries for Gamewell Fire Alarm Telegraph Co. systems in banks. Several years ago, I did an exhaustive internet search on Gamewell and could not learn anything about the support for the batteries, but Steve Coffman was able to find a couple of references recently that confirmed how the insulators were used. One article described a Gamewell system installed in East Watertown, MA in 1906 for the Fire and Police Departments. The article in the April 14, 1917, issue of *Electrical Review and Western Electrician* gave this detailed account of the battery room in the Holyoke, MA Central Fire-Alarm Office:

“The battery room at the rear of the central office contains three rows of five shelves, each of insulated metal battery racks with capacity for 500 storage cells of the couple type. These are connected on the A and B banks. The couples are mounted in glass jars on glass rods and porcelain insulators. Each set of batteries on each circuit is protected by three-ampere cartridge fuses. The batteries are connected to the storage-battery switchboard through wires concealed in the ducts, which enter floor boxes under each post. The wires enter the pipe posts from below and connect to the fuse blocks.

A private-branch-exchange telephone switchboard with 10 auxiliary lines to official and engine-house instruments is used for fire-department calls. It is also connected with the New England Telephone Company's system by three trunk lines for public calls.

The complete system was installed by the Gamewell Fire Alarm Telegraph Company, of New York, under the direction of A. D. Wheeler, its New England agent. The installation work was done by E. P. Cochrane and G. A. Broder, construction engineers for Gamewell Company."

The batteries were used to maintain current in order to send a telegraph alarm message to the fire or police departments. There are grooves in the bottom of Gamewell glass battery jars to secure them on the glass rods supported by the little porcelain insulators. Apparently, the plug-bottom of the insulators fit in holes in metal battery support racks. The Watertown article stated the storage batteries were "mounted on iron pipe racks with porcelain insulators and glass rods."



Gamewell glass battery jar with grooves in bottom.

Some of the insulators were originally found in a bank in Georgia or somewhere in the South. At least one insulator has been reported that was embossed on the bottom part: GAMEWELL 60. Here is a photo of the separate parts of the 2-part Gamewell insulator.



The head on the right is very different and requires a slotted type of base that I do





not have. Perhaps it is an early version that fit in the iron pipe rack.





The above article on Gamewell battery rests is from:
<https://www.r=infinity.com/Gamewellindex.htm>

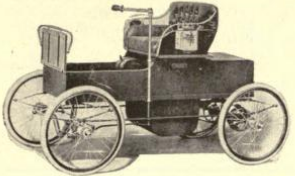
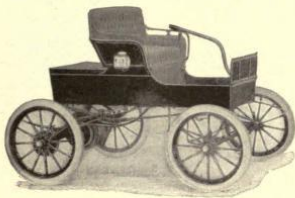

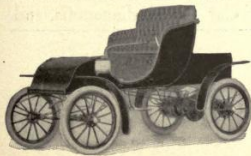

22 APPENDIX D ELECTRIC VEHICLES CIRCA 1905

Following is a list of available electric cars circa 1905.



ELECTRIC PLEASURE CARS COSTING LESS THAN \$1,600.			
	Juvenile Electric Runabout. The American Metal Wheel and Auto Co., Toledo, O.		
<p>PRICE: \$800 BODY: Runabout SEATS: 2 passengers WEIGHT: 350 pounds WHEEL BASE: 41 inches TREAD: 29 inches</p>	<p>WHEELS: 20 in.; cushion tires STEERING: Side lever BRAKES: Hand brake on controller SPRINGS: Full elliptic FRAME: Steel</p>	<p>CURRENT SUPPLY: Battery of 6 cells MILEAGE CAPACITY: 20 miles SPEED: 8 to 10 miles per hour SPEEDS: 2 forward and 2 reverse DRIVE: Chain</p>	
	Pope-Waverley, Model 21, Runabout. Pope Motor Car Co., Indianapolis, Ind.		
<p>PRICE: \$850 BODY: Piano box pattern SEATS: 2 persons WHEEL BASE: 61 inches TREAD: 54 inches TIRES, FRONT: 30x2½ in.</p>	<p>TIRES, REAR: 30x3 in. STEERING: Center lever BRAKES: Two foot and one electric SPRINGS: Full elliptic MOTOR SUSPENSION: Rear axle</p>	<p>CURRENT SUPPLY: 24 cells of 9 P. V. oxide GEARING: Herringbone type SPEED: 5 to 15 m. p. h. DRIVE: Direct</p>	
	Pope-Waverley, Model 36. Pope Motor Car Co., Indianapolis, Ind.		
<p>PRICE: \$900 BODY: Road wagon SEATS: 2 persons WHEEL BASE: 72 inches TREAD: 54 inches</p>	<p>TIRES, FRONT: 30x2½ in. TIRES, REAR: 30x3 in. STEERING: Center lever BRAKES: Two foot and one electric SPRINGS: Full elliptic</p>	<p>MOTOR: One, special CURRENT SUPPLY: 24 cells, 9 P. V. oxide GEARING: Herringbone type DRIVE: Direct</p>	
	Columbia Runabout, Mark LX. Electric Vehicle Co., Hartford, Conn.		
<p>PRICE: \$900 BODY: Runabout SEATS: 2 persons WEIGHT: 1,300 pounds WHEEL BASE: 64 inches TREAD: 48 inches TIRES, FRONT: 30x2½ inches TIRES, REAR: 30x2½ inches</p>	<p>STEERING: Hinged side lever BRAKES: Band type, foot operated SPRINGS: Half elliptic HORSE-POWER: 3½ brake MOTORS: One, series wound, 40 V. 32A. BATTERY: 20 cells, 11 P. V. oxide</p>	<p>BATTERY ARRANGEMENT: In two trays CAPACITY: 120 amp. hours at 30 amp. rate NORMAL SPEEDS: 5, 10, 15 m.p.h. forward, 5, 10 m.p.h. reverse DRIVE: Chain.</p>	

	Studebaker, Model 22a.	Studebaker Automobile Co., South Bend, Ind.
<p>PRICE: \$1,050 BODY: Runabout style, open SEATS: 2 persons WEIGHT: 1,400 pounds WHEEL BASE: 67 inches TREAD: 54 inches TIRES, FRONT: 30x3 inches TIRES, REAR: 30x3 inches STEERING: By side lever</p>	<p>BRAKES: One operating on motor drum; one operating on rear axle SPRINGS: Front, semi-elliptic; rear, full elliptic MOTOR RATING: 40 volts, 24 amperes BATTERY: 24 cells, 9 plate BATTERY ARRANGEMENT: Assembled in three trays</p>	<p>MOTOR SUSPENSION: Hung from body MOTOR CONTROL: By controller located left side of seat SPEEDS: 3 to 14 miles per hour DRIVE: Through medium of chain and sprockets</p>
	Pope-Waverley, Model 29 Physician's Wagon. Pope Motor Car Co., Indianapolis, Ind.	
<p>PRICE: \$1,150 BODY: Straight sill SEATS: 2 persons WHEEL BASE: 72 inches TREAD: 54 inches</p>	<p>TIRES, FRONT: 30x3 in. TIRES, REAR: 30x3½ in. STEERING: Center lever BRAKES: Two foot and one electric SPRINGS: Full elliptic</p>	<p>MOTOR: One, special CURRENT SUPPLY: 30 cells of 9 P. V. oxide GEARING: Herringbone type SPEEDS: 5 to 16 m. p. h. DRIVE: Direct</p>
	Baker Imperial. Baker Motor Vehicle Co., Cleveland, O.	
<p>PRICE: \$1,200 BODY: Piano box type SEATS: 2 persons WEIGHT: 1,000 pounds WHEEL BASE: 68 inches TREAD: 48½ inches</p>	<p>TIRES, FRONT: 30 x 3½ inches TIRES, REAR: 30 x 3½ inches STEERING: Side lever BRAKES: Two MOTOR SUSPENSION: Under body</p>	<p>CAPACITY: 50 miles on one charge SPRINGS: Full elliptic CURRENT SUPPLY: 14 cell battery, 9 MV. SPEED: 14 and 17 m. p. h. DRIVE: Center chain</p>
	Pope-Waverley, Model 26, Chelsea. Pope Motor Car Co., Indianapolis, Ind.	
<p>PRICE: \$1,200 BODY: Straight sill, swelled panels SEATS: 2 persons WHEEL BASE: 80 inches TREAD: 54 inches TIRES, FRONT: 30x3 inches</p>	<p>TIRES, REAR: 30x3½ inches* STEERING: Center lever BRAKES: Two foot and one electric SPRINGS: Full elliptic MOTOR: One, special</p>	<p>CURRENT SUPPLY: 30 cells, 9 P. V. oxide GEARING: Herringbone type SPEED: 5 to 16 m. p. h. DRIVE: Direct</p>



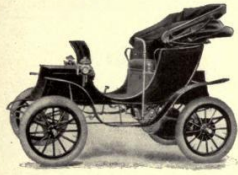

115





	Pope-Waverley, Model 69, Runabout. Pope Motor Car Co., Indianapolis, Ind.	
<p>PRICE: \$1,225 (with top) BODY: Runabout SEATS: 2 persons WHEEL BASE: 72 inches TREAD: 54 inches TIRES, FRONT: 30x3 in.</p>	<p>TIRES, REAR: 30x3½ in. STEERING: Center or side lever BRAKES: Two foot and one electric SPRINGS: Full elliptic MOTOR SUSPENSION: On rear axle</p>	<p>CURRENT SUPPLY: 30 cells of 9 P. V. oxide GEARING: Herringbone type SPEEDS: 5 to 17 m. p. h. DRIVE: Direct</p>
	Studebaker, Model 22b. Studebaker Automobile Co., South Bend, Indiana	
<p>PRICE: \$1,250, with top BODY: Stanhope SEATS: 2 persons WEIGHT: 1,650 pounds WHEEL BASE: 67 inches TREAD: 54 inches TIRES, FRONT: 30x3 inches TIRES, REAR: 30x3 inches STEERING: By side lever</p>	<p>BRAKES: One operating on motor drum; one operating on rear axle SPRINGS: Front, semi-elliptic; rear, full elliptic MOTOR RATING: 40 volts, 24 amperes BATTERY: 24 cell, 9 plate BATTERY ARRANGEMENT: Assembled in three trays</p>	<p>MOTOR SUSPENSION: Hung from body MOTOR CONTROL: By controller located left side of seat SPEEDS: 3 to 14 miles per hour DRIVE: Through medium of chain and sprockets</p>
	Pope-Waverley Model 29C, Physicians' Wagon. Pope Motor Car Co., Indianapolis, Ind.	
<p>PRICE: \$1,250 BODY: Straight sill, with removable canopy top SEATS: 2 persons WHEEL BASE: 72 inches TREAD: 54 inches</p>	<p>TIRES, FRONT: 30x3 in. TIRES, REAR: 30x3½ in. STEERING: Center lever BRAKES: Two foot and one electric SPRINGS: Full elliptic MOTOR: One, special</p>	<p>CURRENT SUPPLY: 30 cells of 9 P. V. oxide GEARING: Herringbone type SPEED: 5 to 16 m. p. h. DRIVE: Direct</p>
	Pope-Waverley, Model 65. Pope Motor Car Co., Indianapolis, Ind.	
<p>PRICE: \$1,400 BODY: Stanhope SEATS: 2 persons WHEEL BASE: 70 inches TREAD: 54 inches</p>	<p>TIRES, FRONT: 30x3 in. TIRES, REAR: 30x3½ in. STEERING: Center lever BRAKES: Two foot, 1 electric SPRINGS: Full elliptic</p>	<p>MOTOR: One, special CURRENT SUPPLY: 30 cells of 11 P. V. oxide GEARING: Herring bone type SPEED: 5 to 16 miles per hour DRIVE: Direct</p>

116



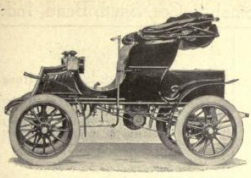

	Babcock, Model 5, Roadster.	Babcock Electric Carriage Co., Buffalo, N. Y.
	PRICE: \$1,400 BODY: Wood SEATS: 2 people WEIGHT: 1,500 pounds WHEEL BASE: 78 inches TREAD: 53 inches	MOTOR: 1½ H.P. normal MOTOR SUSPENSION: From chassis under seat TIRES, FRONT: 32x3½ inches TIRES, REAR: 32x3½ inches STEERING: Wheel
		BRAKES: Hub and electric SPEED: 6 to 30 M.P.H. SPRINGS: Full elliptic FRAME: Armored wood SPEEDS: 6 forward; 2 reverse DRIVE: Double chain
	Columbia Victoria Phaeton, Model 69.	Electric Vehicle Co., Hartford, Conn.
	PRICE: \$1,500 BODY: Wooden, Victoria phaeton SEATS: 2 passengers WEIGHT: 1,700 pounds WHEEL BASE: 70 inches TREAD: 48 inches TIRES, FRONT: 30x3½ inches TIRES, REAR: 30x3½ inches	STEERING: Hand side lever BRAKES: Foot, double acting SPRINGS: Semi-elliptic FRAME: Steel HORSE-POWER: 3.5 brake H.P. maximum MOTOR SUSPENSION: Single G. E. type motor, under body in rear
		BATTERY: Divided oxide battery of 24 cells CAPACITY: About 40 miles MILEAGE: 40 miles per charge SPEEDS: 3 forward speeds and 2 reverse DRIVE: Chain
	Columbia Surrey, Mark XIX.	Electric Vehicle Co., Hartford, Conn.
	PRICE: \$1,500 BODY: Surrey type SEATS: 4 persons WEIGHT: 2,800 pounds WHEEL BASE: 68½ inches TREAD: 41 inches TIRES, FRONT: 32x3 in. pneumatic TIRES, REAR: 32x3 in. solid	STEERING: Hinged side lever BRAKES: Band type on driving gear and emergency on motor shaft SPRINGS: Two full elliptic, rear; one 2 spring, front FRAME: Steel HORSE-POWER: 3.5 each, maximum
		MOTORS: Two, G. E. type, series wound, 80V., 16 Amp. BATTERY: 40 cells, 9 MV. oxide MILEAGE: 40 miles per charge SPEEDS: 3 forward and 3 reverse DRIVE: Internal gearing





ELECTRIC PLEASURE CARS COSTING FROM \$1,600 TO \$2,499.		
	Babcock, Model 6.	Babcock Electric Carriage Co., Buffalo, N. Y.
	PRICE: \$1,600 BODY: Victoria phaeton SEATS: 2 people WEIGHT: 1,600 pounds WHEEL BASE: 78 inches TREAD: 54 inches	TIRES, FRONT: Pneumatic, 32x3 inches TIRES, REAR: Pneumatic, 32x3 inches STEERING: Wheel BRAKES: 2 hand brakes on hubs MOTOR: 1½ H.P. normal.
		SPEED: 6 to 25 m. p. h. SPRINGS: Front, one-half platform; rear, full elliptic FRAME: Armored wood SPEEDS: 6 forward and reverse DRIVE: Double chain
	Baker Stanhope.	Baker Motor Vehicle Co., Cleveland, O.
	PRICE: \$1,600 BODY: Stanhope SEATS: 2 persons WEIGHT: 1,950 pounds WHEEL-BASE: 68 inches TREAD: 48½ inches	TIRES, FRONT: 30x3½ inches TIRES, REAR: 30 x 3½ inches STEERING: Side lever BRAKES: Two MOTOR SUSPENSION: Under body
		CAPACITY: 50 miles SPRINGS: Full elliptic CURRENT SUPPLY: 14-cell battery, 9 m. v. SPEED: 14 and 17 m. p. h. DRIVE: Center chain
	Columbus Electric, Stanhope, Model 1000, 1½ H.P.	Columbus Buggy Co., Columbus, Ohio
	PRICE: \$1,600 BODY: Stanhope, phaeton SEATS: 2 persons WEIGHT: 1,650 pounds WHEEL BASE: 69 inches TREAD: 50½ inches TIRES, FRONT: 30x3½ inches TIRES, REAR: 30x3½ inches STEERING: Side lever	BRAKES: On jack shaft, and rear hubs SPRINGS: Half platform, front; full elliptic, rear FRAME: Pressed steel MOTOR SUSPENSION: On sub-frame CURRENT SUPPLY: Storage battery, 24 cells
		LUBRICATION: Grease all roller and Hess Bright bearings MOTOR-CONTROL: Radial type with reverse and speed changes combined SPEEDS: 4 forward and reverse DRIVE: Double chain
	Babcock, Model No. 1.	Babcock Electric Carriage Co., Buffalo, N. Y.
	PRICE: \$1,650 BODY: Stanhope SEATS: 2 persons WEIGHT: 1,000 pounds WHEEL BASE: 66 inches TREAD: 53 inches	TIRES, FRONT: 32x1¾ ins., solid TIRES, REAR: 36x2 ins., solid STEERING: Wheel BRAKES: Electric and hand SPRINGS: Full elliptic FRAME: Wood
		MOTOR: 3 H.P. normal BATTERY: 40 cells CAPACITY: 50 miles CONTROL: 3 forward and 2 reverse speeds DRIVE: Gear direct

	Studebaker, Model 13a.	Studebaker Automobile Co., South Bend, Ind.	
	<p>PRICE: \$1,650, with top BODY: Stanhope SEATS: 2 persons WEIGHT: 2,350 pounds WHEEL BASE: 73 inches TREAD: 54 inches TIRES, FRONT: 30x3½ inches TIRES, REAR: 30x3½ inches STEERING: By side lever</p>	<p>BRAKES: One operating on motor drum; one operating on rear axle SPRINGS: Front, semi-elliptic; rear, full elliptic FRAME: Tubular MOTOR RATING: 50 volts, 30 amperes BATTERY: 36 cell, 9 plate SPEEDS: 3 to 18 miles per hour</p>	<p>BATTERY ARRANGEMENT: Assembled in three trays MOTOR SUSPENSION: Hung from frame MOTOR CONTROL: By controller located left side of seat DRIVE: Through medium of chain and sprockets</p>
	Pope-Waverley, Model 60B, Surrey.	Pope Motor Car Co., Indianapolis, Ind.	
	<p>PRICE: \$1,700, with top BODY: Straight sill, panel seat SEATS: 4 persons WHEEL BASE: 90 inches TREAD: 54 inches</p>	<p>TIRES, FRONT: 30x3½ in. TIRES, REAR: 30x4 in. STEERING: Side lever BRAKES: Two foot and one electric SPRINGS: Full elliptic</p>	<p>MOTORS: Two, special CURRENT SUPPLY: 42 cells of 9 P. V. oxide GEARING: Herringbone type SPEED: 5 to 15 m. p. h. DRIVE: Direct</p>
	Pope-Waverley, Model 26C, Chelsea.	Pope Motor Car Co., Indianapolis, Ind.	
	<p>PRICE: \$1,700 BODY: With removable coupe top SEATS: 2 persons WHEEL BASE: 80 inches TREAD: 54 inches</p>	<p>TIRES, FRONT: 30x3 in. TIRES, REAR: 30x4 in. STEERING: Center lever BRAKES: Two foot and one electric SPRINGS: Full elliptic</p>	<p>MOTOR: One, special CURRENT SUPPLY: 30 cells of 11 P. V. oxide GEARING: Herringbone type SPEED: 4 to 15 m. p. h. DRIVE: Direct</p>
	Cantono Fore Carriage.	Cantono Electric Fore Carriage Co., New York	
	<p>PRICE: \$1,750 NOTE: The Cantono Electric Fore Carriage is sold individually at the above price, which includes the attaching of same to any horse-drawn vehicle, converting it to an electric carriage. Complete vehicles are also marketed by this concern. (See page 80.)</p>	<p>STEERING: Electrical and mechanical combination type BRAKES: Electric, on wheels MOTORS: Two; one on each wheel HORSE-POWER: 2½ each</p>	<p>MOTOR SUSPENSION: On axle BATTERY: 44 cells, Exide SPEEDS: 4 forward, 2 reverse DRIVE: Direct, on wheels</p>

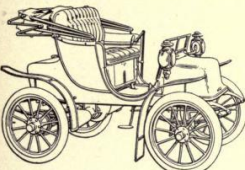

119

	Studebaker, Model 16a.	Studebaker Automobile Co., South Bend, Ind.	
	<p>PRICE: \$1,750, with top BODY: Victoria SEATS: 2 persons WEIGHT: 2,000 pounds WHEEL BASE: 68 inches TREAD: 54 inches TIRES, FRONT: 30x3½ inches TIRES, REAR: 30x3½ inches STEERING: By side lever</p>	<p>BRAKES: One operating on motor drum; one operating on rear axle SPRINGS: Front, semi-elliptic; rear, full elliptic MOTOR RATING: 50 volts, 30 amperes BATTERY: 28 cells, 9 plate BATTERY ARRANGEMENT: Assembled in three trays</p>	<p>MOTOR SUSPENSION: Hung from body MOTOR CONTROL: By controller located left side of seat SPEEDS: 3 to 14 miles per hour DRIVE: Through medium of chain and sprockets</p>
	Babcock, Model 1, Stanhope Special. Babcock Electric Carriage Co., Buffalo, N. Y.		
	<p>PRICE: \$1,800 BODY: Stanhope SEATS: 2 persons WEIGHT: 1,900 pounds WHEEL BASE: 66 inches TREAD: 53 inches</p>	<p>MOTOR: 3 H.P., normal TIRES, FRONT: Solid, 32x1¾ in. TIRES, REAR: Solid, 36x2 in. STEERING: Wheel BRAKES: Band brakes and electric</p>	<p>BATTERY: 40 cells SPRINGS: Full elliptic FRAME: Wood SPEEDS: 6 forward; 1 reverse DRIVE: Gear, direct</p>
	Baker Runabout, Model L.	Baker Motor Vehicle Co., Cleveland, Ohio	
	<p>PRICE: \$1,800 BODY: Wood, runabout SEATS: 2 persons WEIGHT: 1,500 pounds WHEEL BASE: 70 inches TREAD: 56 inches TIRES, FRONT: 30x3½ inches</p>	<p>TIRES, REAR: 30x3½ inches STEERING: Side lever BRAKES: Two foot brakes, external and internal on rear wheels SPRINGS: Semi-elliptic in front; full elliptic in rear</p>	<p>FRAME: Armored wood MOTOR: 2 H.P., 300% overload BATTERY: 24 cells, 9 m. v. CAPACITY: 80 miles SPEEDS: 6 forward and 3 reverse DRIVE: Single chain</p>
	Baker Queen Victoria, Model L.	Baker Motor Vehicle Co., Cleveland, Ohio	
	<p>PRICE: \$1,800 BODY: Wood, runabout SEATS: 2 persons WEIGHT: 1,500 pounds WHEEL BASE: 70 inches TREAD: 56 inches TIRES, FRONT: 30x3½ inches</p>	<p>TIRES, REAR: 30x3½ inches STEERING: Side lever BRAKES: Two foot brakes, external and internal on rear wheels SPRINGS: Semi-elliptic in front; full elliptic in rear</p>	<p>FRAME: Armored wood MOTOR: 2 H.P., 300% overload BATTERY: 24 cells, 9 m. v. CAPACITY: 80 miles SPEEDS: 6 forward and 3 reverse DRIVE: Single chain</p>

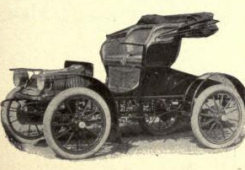

120



	<p>Williams New Electric.</p> <p>PRICE: \$1,800 BODY: Victoria phaeton SEATS: 2 persons WEIGHT: 1,700 pounds WHEEL BASE: 71 inches TREAD: 54 inches TIRES, FRONT: 34x3 inches</p>	<p>Williams Electric Vehicle Co., Cleveland, Ohio</p> <p>TIRES, REAR: 34x3 inches STEERING: Side lever BRAKES: Motor and rear hubs SPRINGS: Elliptic FRAME: Cold pressed steel CURRENT SUPPLY: 24-cell storage battery</p>	<p>CONTROLLER: Automatic SPEED: 16 m.p.h. SPEEDS: 4 forward and reverse SPEED CONTROL: Side lever DRIVE: Side chains</p>
	<p>R & L Stanhope.</p> <p>PRICE: \$1,850 BODY: Stanhope SEATS: 2 persons WEIGHT: 1,600 pounds WHEEL BASE: 73 inches TIRES, FRONT: 32 in., pneumatic TIRES, REAR: 32 in., pneumatic STEERING: Side lever</p>	<p>Rauch and Lang Carriage Co., Cleveland, Ohio</p> <p>BRAKES: On rear wheels and emergency SPRINGS: Semi-elliptic front; full elliptic rear FRAME: Steel HORSE-POWER: 1 1/4 MOTOR: Hertner</p>	<p>MOTOR SUSPENSION: Under body SPEED: 1-22 m. p. h. DISTANCE: 75 to 80 miles MOTOR CONTROL: Lever at left of seat DRIVE: Double chain from counter-shaft</p>
	<p>Columbus Electric, Coupe, Model 1002, 1 1/2 H.P.</p> <p>PRICE: \$1,900 BODY: Coupe SEATS: 2 persons WEIGHT: 1,650 pounds WHEEL BASE: 69 inches TREAD: 50 1/2 inches TIRES, FRONT: 30x3 1/2 inches TIRES, REAR: 30x3 1/2 inches STEERING: Side lever</p>	<p>Columbus Buggy Co., Columbus, O.</p> <p>BRAKES: One on jack shaft, one on each rear wheel SPRINGS: Front, half platform; rear, full elliptic FRAME: Pressed steel MOTOR SUSPENSION: Sub-frame CURRENT SUPPLY: Storage battery</p>	<p>LUBRICATION: Grease all roller and Hess Bright bearings MOTOR CONTROL: Radial type with reverse and speed changes combined SPEEDS: 4 forward and reverse DRIVE: Double chain</p>
	<p>Baker Suburban.</p> <p>PRICE: \$2,000 SEATS: 2 persons WEIGHT: 1,850 pounds WHEEL BASE: 82 inches TREAD: 56 inches TIRES, FRONT: 34 x 3 1/2 inches</p>	<p>Baker Motor Vehicle Co., Cleveland, O.</p> <p>TIRES, REAR: 34 x 4 inches STEERING: Side lever BRAKES: On rear wheel drums SPRINGS: Semi-elliptic FRAME: Pressed steel MOTOR SUSPENSION: In front</p>	<p>MOTOR: 2 1/2 H.P. BATTERY: 28 cells, 11 m. v. MOTOR CONTROL: Lever at left side SPEEDS: 14, 18 and 22 m. p. h. DRIVE: Bevel gear</p>

121

	<p>Woods Electric.</p> <p>PRICE: \$2,000 BODY: Victoria, leather top SEATS: 3 to 5 persons WEIGHT: 2,500 pounds WHEEL BASE: 80 inches TREAD: 56 inches TIRES, FRONT: 32x2 1/2 in. (solid)</p>	<p>Woods Motor Vehicle Co., Chicago, Ill.</p> <p>TIRES, REAR: 34x2 1/2 in. (solid) STEERING: Side lever BRAKES: Internal expanding SPRINGS: Special platform FRAME: Armored wood CURRENT SUPPLY: Storage battery</p>	<p>MOTOR CONTROL: 4 forward and reverse TRANSMISSION: Annular ball bearings SPEED: 18 miles per hour SPEED CONTROL: Side lever DRIVE: Side chain</p>
	<p>Baker Inside Driven Coupe Model L.</p> <p>PRICE: \$2,000 BODY: Wood SEATS: 2 persons WEIGHT: 1,650 pounds WHEEL BASE: 70 inches TREAD: 56 inches TIRES, FRONT: 30x3 1/2 inches</p>	<p>Baker Motor Vehicle Co., Cleveland, Ohio</p> <p>TIRES, REAR: 30x3 1/2 inches STEERING: Side lever BRAKES: Two foot brakes, external and internal on rear wheels SPRINGS: Semi-elliptic in front; full elliptic in rear</p>	<p>FRAME: Armored wood MOTOR: 2 H.P., 300% overload BATTERY: 24 cells, 9 m.v. CAPACITY: 80 miles SPEEDS: 6 forward and 3 reverse DRIVE: Single chain</p>
	<p>Pope-Waverley, Stanhope, Model 53A.</p> <p>PRICE: \$2,000 BODY: With removable top SEATS: 2 persons WEIGHT: 1,500 pounds WHEEL BASE: 76 inches TREAD: 54 inches TIRES, FRONT: 32x3 1/2 in.</p>	<p>Pope Motor Car Co., Indianapolis, Ind.</p> <p>TIRES, REAR: 32x4 in. STEERING: Wheel, worm and gear BRAKES: Two foot and one electric SPRINGS: Long semi-elliptic FRAME: Pressed steel MOTOR: One, special</p>	<p>CURRENT SUPPLY: 30 cells, 11 M. V. oxide GEARING: Herringbone type SPEED: 5 to 18 miles per hour DRIVE: Direct</p>
<p><i>Maker's illustration not ready—will be published later and of a size suitable for insertion in this space.</i></p>	<p>Electric Phaeton, Model 1.</p> <p>PRICE: \$2,000 BODY: Queen phaeton SEATS: 2 persons WEIGHT: 1,500 pounds WHEEL BASE: 72 inches TREAD: 54 inches</p>	<p>S. R. Bailey & Co., Amesbury, Mass.</p> <p>TIRES, FRONT: 34 x 3 inches TIRES, REAR: 34 x 3 inches STEERING: Wheel BRAKES: Band to motor and rear wheels SPRINGS: Half-elliptic</p>	<p>FRAME: Pat. angle and tee steel CURRENT SUPPLY: Storage battery SPEEDS: 4, ahead and back, up to 18 m. p. h. DRIVE: Double chain</p>

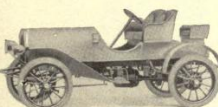

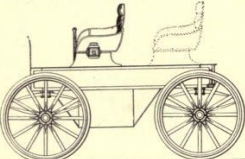

122





	Studebaker, Model 15a. Studebaker Automobile Co., South Bend, Indianapolis, Ind.	PRICE: \$2,200 BODY: Closed SEATS: 2 persons WEIGHT: 2,100 pounds WHEEL BASE: 68 inches TREAD: 54 inches TIRES, FRONT: 30x3 inches TIRES, REAR: 30x3 inches STEERING: By side lever	BRAKES: One operating on motor drum; one operating on rear axle SPRINGS: Front, semi-elliptic; rear, full elliptic MOTOR RATING: 50 volts, 30 amperes BATTERY: 28 cell, 9 plate BATTERY ARRANGEMENT: Assembled in three trays	MOTOR SUSPENSION: Hung from body MOTOR CONTROL: By controller located left side of seat SPEEDS: 3 to 13 miles per hour DRIVE: Through medium of chain and sprockets
	Pope-Waverley, Model 53B. Pope Motor Car Co. Indianapolis, Ind.	PRICE: \$2,250 BODY: Stanhope with coupe SEATS: 2 persons WHEEL BASE: 76 inches TREAD: 54 inches TIRES, FRONT: 32x3½ inches	TIRES, REAR: 32x4 inches STEERING: Wheel, worm and gear BRAKES: Two foot and one electric SPRINGS: Long semi-elliptic FRAME: Pressed steel	MOTOR: One special CURRENT SUPPLY: 30 cells; 11 M. V. excite GEARING: Herringbone type SPEED: 5 to 18 m. p. h. DRIVE: Direct
	Pope-Waverley, Model 30, Station Wagon. Pope Motor Car Co., Indianapolis, Ind.	PRICE: \$2,250 BODY: Swelled panels SEATS: 4 persons WHEEL BASE: 77½ inches TREAD: 54 inches	TIRES, FRONT: 30x4 in. TIRES, REAR: 30x4 in. STEERING: Side lever BRAKES: Two foot, one electric SPRINGS: Full elliptic MOTOR SUSPENSION: Rear axle	CURRENT SUPPLY: 41 cells of 11 P. V. excite GEARING: Herringbone type SPEED: 4 to 15 m. p. h. DRIVE: Direct
	Baker Roadster, Model M. Baker Motor Vehicle Co., Cleveland, Ohio	PRICE: \$2,250 BODY: Wood runabout with rumble seat SEATS: 3 persons WEIGHT: 2,400 pounds WHEEL BASE: 95 inches TREAD: 56 inches	TIRES, FRONT: 34x3½ inches TIRES, REAR: 34x4 inches STEERING: Wheel BRAKES: 2 internal on rear wheel, 1 internal on transmission shaft SPRINGS: Semi-elliptic front and rear	FRAME: Armored wood MOTOR: 3½ H.P., 300% overload BATTERY: 32 cells, 11 p.v. CAPACITY: About 60 miles SPEEDS: 6 forward and 3 reverse DRIVE: Planetary gear reduction; shaft and bevel gear drive



	R & L Extension Front Coupe. Rauch and Lang Carriage Co., Cleveland, Ohio	PRICE: \$2,300 BODY: Coupe SEATS: 2 persons WEIGHT: 1,800 pounds WHEEL BASE: 73 inches TIRES, FRONT: 32 in., pneumatic TIRES, REAR: 32 in., pneumatic STEERING: Side lever	BRAKES: On rear wheels and emergency SPRINGS: Semi-elliptic front; full elliptic rear FRAME: Pressed steel HORSE-POWER: 1½ MOTOR: Hertner	MOTOR SUSPENSION: Under body SPEED: 1-22 m. p. h. DISTANCE: 75 miles MOTOR CONTROL: Lever at left of seat DRIVE: Double chain from counter-shaft
	"Hercules," Model 140. James Macnaughtan Co., Buffalo, N. Y.	PRICE: \$2,350 BODY: Piano box SEATS: 2 or 4 persons CAPACITY: 1,500 pounds WEIGHT: 3,300 pounds TIRES, FRONT: 36x3 inches	TIRES, REAR: 39x3½ inches STEERING: Irreversible type BRAKES: Internal expanding hub SPRINGS: Full elliptic MOTORS: Double equipment	MOTOR SUSPENSION: From body MOTOR CONTROL: Westinghouse SPEEDS: 4 ahead and reverse DRIVE: Double chain
	Columbus Electric, Surrey, Model 1100, 2 1-2 H.P. Columbus Buggy Co., Columbus, O.	PRICE: \$2,400 BODY: 2-seated, open, with canopy top SEATS: 4 persons WEIGHT: 2,200 pounds WHEEL BASE: 89 inches TREAD: 54 inches TIRES, FRONT: 34x4 inches TIRES, REAR: 34x4 inches	STEERING: Side lever BRAKES: One on jack shaft and rear wheels SPRINGS: Front, half platform; rear, full elliptic FRAME: Pressed steel MOTOR SUSPENSION: Sub-frame LUBRICATION: Grease all roller and Hess Bright bearings	CURRENT SUPPLY: Storage battery MOTOR CONTROL: Radial type, with reverse and speed control combined SPEEDS: 16 miles per hour DRIVE: Side chains





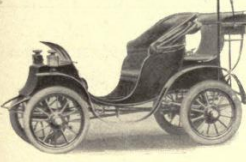

ELECTRIC PLEASURE CARS COSTING \$2,500 AND OVER.

	<p>Columbia Opera Bus, Mark XI. Electric Vehicle Co., Hartford, Conn.</p> <p>PRICE: \$2,500 BODY: Rear entrance bus SEATS: 6 persons inside WEIGHT: 2,330 pounds WHEEL BASE: 69 inches TREAD: 67 inches TIRES, FRONT: 36x3½ in. solid</p> <p>TIRES, REAR: 42x3½ in. solid STEERING: Hinged tiller BRAKES: Metallic shoe type SPRINGS: Platform, rear; one x spring, front FRAME: Steel HORSE-POWER: 3.5 brake h.p.</p> <p>MOTOR: One Westinghouse type, series wound, 80 V., 40 Amp. BATTERY: 44 cells, 9 T.V. oxide MILEAGE: 35 miles on one charge SPEEDS: 3 forward and 3 reverse DRIVE: Internal gear</p>
	<p>Babcock Coupe, Model 8. Babcock Electric Carriage Co., Buffalo, N. Y.</p> <p>PRICE: \$2,500 BODY: Coupe with drop windows SEATS: 2 persons WEIGHT: 2,000 pounds WHEEL BASE: 69 inches TIRES, FRONT: 32x3 inches TIRES, REAR: 36x3½ inches</p> <p>STEERING: Tilting wheel BRAKES: In rear hub drums and electric by controller handle SPRINGS: Full elliptic MOTOR: 3 H.P., normal</p> <p>BATTERY: Divided; half in front and half in rear CAPACITY: 50 miles CONTROLLER: 3 forward and 2 reverse speeds DRIVE: Direct by gear</p>
	<p>"Hercules," Model 141. James Macnoughtan Co., Buffalo, N. Y.</p> <p>PRICE: \$2,500 BODY: Landaulet SEATS: 2 passengers WEIGHT: 2,600 pounds WHEEL BASE: 75 inches TREAD: 66 inches TIRES, FRONT: 36x3½ inches</p> <p>TIRES, REAR: 36x3½ inches STEERING: Horizontal side lever elliptic rear BRAKES: Internal expanding hub SPRINGS: Semi-elliptic, front; full elliptic, rear FRAME: Wood MOTORS: Single equipment</p> <p>MOTOR SUSPENSION: From body MOTOR CONTROL: Westinghouse SPEEDS: 4 forward and reverse DRIVE: Double chain</p>
	<p>R & L Surrey. Rauch and Lang Carriage Co., Cleveland, Ohio</p> <p>PRICE: \$2,500 (without top) BODY: Surrey SEATS: 2 persons WEIGHT: 3,000 pounds WHEEL BASE: 91 inches TREAD: 82 in., pneumatic TIRES, REAR: 32 in., pneumatic STEERING: Wheel</p> <p>BRAKES: On rear wheels SPRINGS: Semi-elliptic front; full elliptic rear FRAME: Pressed steel HORSE-POWER: 2½ MOTOR: Herzer MOTOR SUSPENSION: Under body</p> <p>DISTANCE: 50 miles SPEED: 1-20 m. p. h. CHANGE-GEAR CONTROL: Hand lever under steering wheel DRIVE: Double chain from counter-shaft</p>





	<p>Woods Victoria, Woods Motor Vehicle Co., Chicago, Ill.</p> <p>PRICE: \$2,600 BODY: Victoria Limousine SEATS: 3 to 5 persons WEIGHT: 2,500 pounds WHEEL BASE: 80 inches TREAD: 56 inches</p> <p>TIRES, FRONT: 32x2½ solid TIRES, REAR: 34x2½ solid STEERING: Side lever BRAKES: Internal expanding SPRINGS: Woods special platform FRAME: Armored wood CURRENT SUPPLY: Storage battery</p> <p>MOTOR CONTROL: 4 speeds forward and reverse TRANSMISSION: Annular ball bearings all over SPEEDS: 18 miles an hour DRIVE: Side chain</p>
	<p>Baker Surrey. Baker Motor Vehicle Co., Cleveland, O.</p> <p>PRICE: \$2,650 (complete) BODY: Surrey SEATS: 4 persons WEIGHT: 2,100 pounds WHEEL BASE: 86½ inches TREAD: 53 inches</p> <p>TIRES, FRONT: 36 x 3½ inches TIRES, REAR: 36 x 4 inches STEERING: Side lever BRAKES: On rear wheel drums SPRINGS: Semi-elliptic FRAME: Pressed steel</p> <p>MOTOR SUSPENSION: In front CURRENT SUPPLY: 24-cell battery MOTOR CONTROL: Side lever SPEEDS: 14 and 17 m. p. h. DRIVE: Bevel gear</p>
	<p>Columbus Electric, Station Wagon, Model 1102, 2 1-2 H.P. Columbus Buggy Co., Columbus, O.</p> <p>PRICE: \$2,950 BODY: 2-seated coupe SEATS: 4 persons WEIGHT: 2,400 pounds WHEEL BASE: 89 inches TREAD: 54 inches TIRES, FRONT: 34x2½ inches TIRES, REAR: 34x2½ inches STEERING: Side lever</p> <p>BRAKES: One on jack shaft and rear wheels SPRINGS: Front, half platform; rear, full elliptic FRAME: Pressed steel MOTOR SUSPENSION: Sub-frame CURRENT SUPPLY: Storage battery</p> <p>LUBRICATION: Grease all roller and Hess Bright bearings MOTOR CONTROL: Radial type with reverse and speed controls combined SPEEDS: 15 miles per hour DRIVE: Side chain</p>
	<p>Baker Depot Carriage. Baker Motor Vehicle Co., Cleveland, O.</p> <p>PRICE: \$3,000 BODY: Closed SEATS: 4 persons WEIGHT: 2,375 pounds WHEEL BASE: 92½ inches TREAD: 66 inches TIRES, FRONT: 36 x 3½ inches</p> <p>TIRES, REAR: 36 x 4½ inches STEERING: Side lever BRAKES: On rear wheel drums SPRINGS: Semi-elliptic FRAME: Pressed steel MOTOR SUSPENSION: In front, under hood</p> <p>CURRENT SUPPLY: 24-cell battery MOTOR CONTROL: Side lever SPEEDS: 14 and 17 m. p. h. DRIVE: Bevel gear</p>



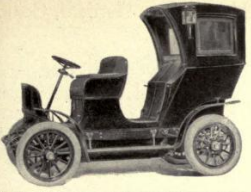

	Baker Coupe.	Baker Motor Vehicle Co., Cleveland, Ohio
PRICE: \$3,000 BODY: Front driven coupe SEATS: 2 inside WEIGHT: 2,400 pounds WHEEL BASE: 62½ inches TREAD: 56 inches	TIRES, FRONT: 36x3¼ inches TIRES, REAR: 36x4½ inches STEERING: Side lever BRAKES: On rear axle and transmission shaft SPRINGS: Semi-elliptic	FRAME: Pressed steel MOTOR: 2½ H.P.; 300% overload BATTERY: 28 cells, 9 IV. CAPACITY: 40 miles SPEEDS: 6 forward and 3 reverse DRIVE: Shaft and bevel gear
	Baker Victoria.	Baker Motor Vehicle Co., Cleveland, Ohio
PRICE: \$3,000 BODY: Victoria SEATS: 2 persons WEIGHT: 2,400 pounds WHEEL BASE: 86½ inches TREAD: 56 inches	TIRES, FRONT: 36x3¼ inches TIRES, REAR: 36x4½ inches STEERING: Side lever BRAKES: On rear wheels and transmission shaft SPRINGS: Semi-elliptic	FRAME: Pressed steel MOTOR: 2½ H.P.; 300% overload BATTERY: 28 cells, 9 IV. CAPACITY: 40 miles SPEEDS: 6 forward and 3 reverse DRIVE: Shaft and bevel gear
	Lansden, Type 38C.	The Lansden Co., Newark, N. J.
PRICE: \$3,400 BODY: Side entrance tonneau SEATS: 5 persons WEIGHT: 4,000 pounds WHEEL BASE: 91 inches TREAD: 46 inches TIRES, FRONT: 32x4½ inches	TIRES, REAR: 32x4½ inches STEERING: Wheel BRAKES: On countershaft and rear hubs SPRINGS: Semi-elliptical FRAME: Wood armored	MOTOR SUSPENSION: From frame CONTROL: Hand wheel MILEAGE: 50 per charge SPEED: 16 m. p. h. DRIVE: Side chains
	Cantono Brougham.	Cantono Electric Fore Carriage Co., New York
PRICE: \$3,500 BODY: Extension brougham SEATS: 4 persons WEIGHT: 4,000 pounds WHEEL BASE: 84 inches TREAD: 56 inches TIRES, FRONT: 34 x 2½ inches TIRES, REAR: 46 x 1½ inches	STEERING: Electrical and mechanical type BRAKES: Two on front wheels; one on rear wheels FRAME: Usual horse-drawn carriage type HORSE-POWER: 2½ each; 5 (2 motors) coupled MOTOR SUSPENSION: On front axle	SPRINGS: Semi-elliptical CURRENT SUPPLY: 44 cells, Exide MOTOR CONTROL: Side lever, at left hand side SPEEDS: 4 forward, 2 reverse CHANGE-GEAR CONTROL: Control lever DRIVE: Direct, on front wheels

127

	Baker Brougham (Interior Driven).	Baker Motor Vehicle Co., Cleveland, Ohio
PRICE: \$3,500 BODY: Brougham SEATS: 4 persons WEIGHT: 2,200 pounds WHEEL BASE: 86½ inches TREAD: 56 inches	TIRES, FRONT: 36 x 3½ inches TIRES, REAR: 36 x 4½ inches BRAKES: On rear wheel drums SPRINGS: Semi-elliptic MOTOR SUSPENSION: In front, under bonnet	FRAME: Pressed steel CURRENT SUPPLY: 24-cell battery MOTOR CONTROL: Side lever SPEEDS: 14 and 17 m. p. h. DRIVE: Bevel gear
	R & L Depot Wagon.	Rauch and Lang Carriage Co., Cleveland, Ohio
PRICE: \$3,500 BODY: Depot wagon SEATS: 6 passengers WEIGHT: 3,500 pounds WHEEL BASE: 97 inches TIRES, FRONT: 32 in., pneumatic TIRES, REAR: 32 in., pneumatic	STEERING: Wheel BRAKES: Rear wheels SPRINGS: Semi-elliptic front; full elliptic rear FRAME: Pressed steel HORSE-POWER: 2½ MOTOR: Hertner	MOTOR SUSPENSION: Under body DISTANCE: 50 miles SPEEDS: From 1 to 20 m. p. h. DRIVE: Double chain
	Baker Landaulet.	Baker Motor Vehicle Co., Cleveland, Ohio
PRICE: \$4,000 BODY: Landaulet SEATS: 6 persons WEIGHT: 4,000 pounds WHEEL BASE: 89 inches TREAD: 56 inches TIRES, FRONT: 34 x 4 inches	TIRES, REAR: 34 x 4½ inches STEERING: Wheel BRAKES: Two external; two internal, rear wheels SPRINGS: Semi-elliptical FRAME: Pressed steel HORSE-POWER: 5.9; 300% overload	CAPACITY: 50 miles MOTOR SUSPENSION: Front CURRENT SUPPLY: 40 cells, 11 M. V. battery SPEEDS: 12, 14, 16, 20, 24 m. p. h. CHANGE-SPEED CONTROL: On steering wheel DRIVE: Shaft
	Baker Brougham, Model 1.	Baker Motor Vehicle Co., Cleveland, Ohio
PRICE: \$4,000 BODY: Wood (front driven) SEATS: 6 persons WEIGHT: 4,000 pounds WHEEL BASE: 89 inches TREAD: 46 inches TIRES, FRONT: 34x4 inches TIRES, REAR: 34x4½ inches	STEERING: Wheel BRAKES: Two external on rear wheels, operated by foot pedal; 2 internal on rear wheels operated by hand lever SPRINGS: Semi-elliptical front and rear FRAME: Pressed steel	MOTOR: 5.9 H.P.; 300% overload BATTERY: 40 cells, 11 MV. CAPACITY: 50 miles SPEEDS: 6 forward and 3 reverse DRIVE: By silent chain reduction shaft and bevel gear

128

	Columbia Hansom, Mark LXVIII.	Electric Vehicle Co., Hartford, Conn.
<p>PRICE: \$4,000 BODY: Hansom with forward seat SEATS: 3 persons inside WEIGHT: 3,000 pounds WHEEL BASE: 86 inches TREAD: 52 inches TIRES, FRONT: 805x105 mm. TIRES, REAR: 820x120 mm.</p>	<p>STEERING: Hand wheel BRAKES: Internal on wheel hubs SPRINGS: Front, semi-elliptic; rear, 3/4 platform FRAME: Pressed steel MOTOR: Series wound, 80 v., 55 amp.</p>	<p>BATTERY: 44 cells, 13 M.V., Exide special CAPACITY: 40 miles CONTROL: Handle on steering wheel SPEEDS: 5 forward, 3 reverse DRIVE: Double gear reduction, helical type</p>
	Columbia Brougham, Mark LXVIII.	Electric Vehicle Co., Hartford, Conn.
<p>PRICE: \$4,000 BODY: Front driven Brougham SEATS: 4 persons inside WEIGHT: 3,000 pounds WHEEL BASE: 86 inches TREAD: 52 inches TIRES, FRONT: 805x105 mm. TIRES, REAR: 820x120 mm. STEERING: Wheel</p>	<p>BRAKES: On rear wheels and electric cut out SPRINGS: Semi-elliptical FRAME: Pressed steel MOTOR: Series wound, 80 v., 55 amp. MOTOR SUSPENSION: Under body to driving axle</p>	<p>BATTERY: 44 cells, 13 M.V., Exide, carried in single tray under body CAPACITY: 40 miles SPEEDS: 5 forward and 3 reverse CHANGE - SPEED CONTROL: Lever on steering column DRIVE: Direct by gears of helical type</p>
	Babcock Electric, Model 7.	Babcock Electric Carriage Co., Buffalo, N. Y.
<p>PRICE: \$4,000 BODY: Brougham SEATS: 4 persons WEIGHT: 3,500 pounds WHEEL BASE: 72 inches TREAD: 43 inches TIRES, FRONT: 32 x 3 inches TIRES, REAR: 36 x 3 1/2 inches STEERING: Wheel</p>	<p>BRAKES: Electric, and internal on rear wheels SPRINGS: Full elliptic FRAME: Armored wood HORSE-POWER: 3 normal BATTERY ARRANGEMENT: one-half in front and one-half in rear MOTORS: Two</p>	<p>CURRENT SUPPLY: 40 cells, 15 plate SPEED: 20 m. p. h. CHANGE GEARS: 4 forward and 3 reverse CONTROLLER: Operated by handle under steering wheel</p>
	Woods Brougham.	Woods Motor Vehicle Co., Chicago, Ill.
<p>PRICE: \$4,000 BODY: Extension brougham SEATS: 4 persons WEIGHT: 3,500 pounds WHEEL BASE: 106 inches TREAD: 56 inches TIRES, FRONT: 32x3 inches solid TIRES, REAR: 36x3 inches solid</p>	<p>STEERING: Irreversible wheel BRAKES: On countershaft and rear wheels SPRINGS: Platform type FRAME: Wood with steel armor MOTOR: 4 pole electric MOTOR SUSPENSION: From bronze frame</p>	<p>BATTERY: 40 cells, 11 M. V. exide DISTANCE: 50 miles per charge MAXIMUM SPEED: 12 m. p. h. SPEEDS: 4 forward and reverse DRIVE: Double chain</p>

	Columbia Landauet, Mark LXVIII.	Electric Vehicle Co., Hartford, Conn.
<p>PRICE: \$4,000 BODY: Landauet SEATS: 4 persons inside WEIGHT: 3,000 pounds WHEEL BASE: 86 inches TREAD: 52 inches TIRES, FRONT: 805x105 mm. TIRES, REAR: 820x120 mm.</p>	<p>STEERING: Wheel BRAKES: On rear wheels and electric cut out SPRINGS: Semi-elliptical FRAME: Pressed steel MOTOR: Series wound, 80 v., 55 amp.</p>	<p>BATTERY: 44 cells, 13 M.V., Exide CAPACITY: 40 miles CONTROL: Lever on steering column SPEEDS: 5 forward and 3 reverse DRIVE: Gears of helical type; double reduction</p>
	Woods Landauette.	Woods Motor Vehicle Co., Chicago, Ill.
<p>PRICE: \$4,000 BODY: Extension landauette SEATS: 2 inside, and 2 outside WEIGHT: 3,500 pounds WHEEL BASE: 106 inches TREAD: 56 inches TIRES, FRONT: 32x3 in. solid TIRES, REAR: 36x3 in. solid</p>	<p>STEERING: Irreversible wheel BRAKES: Countershaft band, and internal on rear wheels SPRINGS: Platform type FRAME: Wood with steel armor MOTOR: 4 pole electric MOTOR SUSPENSION: On bronze frame</p>	<p>BATTERY: 40 cells, 11 M. V. exide DISTANCE: 50 miles on one charge MAXIMUM SPEED: 17 m. p. h. SPEEDS: 4 forward and reverse DRIVE: Double chain</p>
	Lansden, Type 98CC.	The Lansden Co., Newark, N. J.
<p>PRICE: \$4,000 BODY: Limousine SEATS: 4 inside WEIGHT: 3,500 pounds WHEEL BASE: 108 inches TREAD: 56 inches TIRES, FRONT: 32x3 inches, solid rubber</p>	<p>TIRES, REAR: 32x3 inches, solid rubber STEERING: Wheel BRAKES: On countershaft and rear hubs drums SPRINGS: Semi-elliptical FRAME: Armored wood</p>	<p>MOTOR SUSPENSION: From frame CONTROL: Hand wheel MILEAGE: 50 per charge SPEED: 20 m. p. h. DRIVE: Side chains</p>
	Lansden, Type 40CC.	The Lansden Co., Newark, N. J.
<p>PRICE: \$4,000 BODY: Limousine SEATS: 6 persons WEIGHT: 3,300 pounds WHEEL BASE: 88 inches TREAD: 56 inches TIRES, FRONT: 32x4 1/2 inches</p>	<p>TIRES, REAR: 32x4 1/2 inches STEERING: Wheel BRAKES: On countershaft and internal on rear hubs SPRINGS: Semi-elliptic FRAME: Wood armored</p>	<p>MOTOR SUSPENSION: From frame CONTROL: Hand wheel MILEAGE: 40 per charge SPEED: 20 m. p. h. DRIVE: Side chains</p>

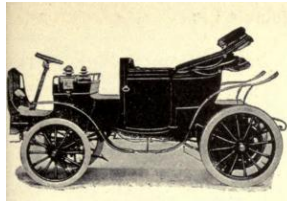

Gallia Electric.

Gallia Electric Carriage Co., New York.

PRICE: \$5,000
 BODY: Landaulet, victoria or cab
 SEATS: 4 persons
 WEIGHT: 4,000 pounds
 WHEEL BASE: 90 inches
 TREAD: 59 inches
 TIRES, FRONT: 870x90 mm.

TIRES, REAR: 1020x120 mm.
 STEERING: Worm and sector
 BRAKES: 5, electrical and mechanical
 SPRINGS: Semi-elliptic, front; full elliptic, rear
 FRAME: Pressed steel

MOTORS: Compound
 BATTERY: Capacity, 240 to 250 ampere hours
 MILEAGE: 50 to 60 miles on one charge
 SPEEDS: 8 forward, 1 reverse
 DRIVE: Direct on wheels



Columbia 8 Passenger Private Bus.

Electric Vehicle Co., Hartford, Conn.

PRICE: \$6,000
 BODY: Side entrance
 SEATS: 8 passengers
 WEIGHT: 5,500 pounds
 WHEEL BASE: 70 inches
 TREAD: 67 inches
 TIRES, FRONT: 36x3 1/2 in. solid

TIRES, REAR: 42x3 1/2 in. solid
 STEERING: Wheel
 BRAKES: Two sets on rear wheels
 SPRINGS: Full elliptic, front; 3/4 elliptic, rear
 FRAME: Steel

BATTERY: Exide
 CONTROL: From steering column
 SPEEDS: 3 forward and 3 reverse
 DRIVE: Direct



Lansden, Model 56, "The Electrette"

The Lansden Co., Newark, N. J.

PRICE: Given by maker upon application
 BODY: Aluminum, with top
 SEATS: 2 persons
 WEIGHT: 1,800 pounds
 WHEEL BASE: 90 inches
 TREAD: 56 inches

TIRES, FRONT: 3 1/2 x 30, pneumatic
 TIRES, REAR: 3 1/2 x 30, pneumatic
 STEERING: Irreversible
 BRAKES: Band on countershaft; internal expanding on rear hubs

SPRINGS: 1 1/2 x 6 in. semi-elliptic
 FRAME: Wood, armored
 MOTOR SUSPENSION: Single motor on frame
 SPEEDS: 3 forward, 2 back
 DRIVE: Chain



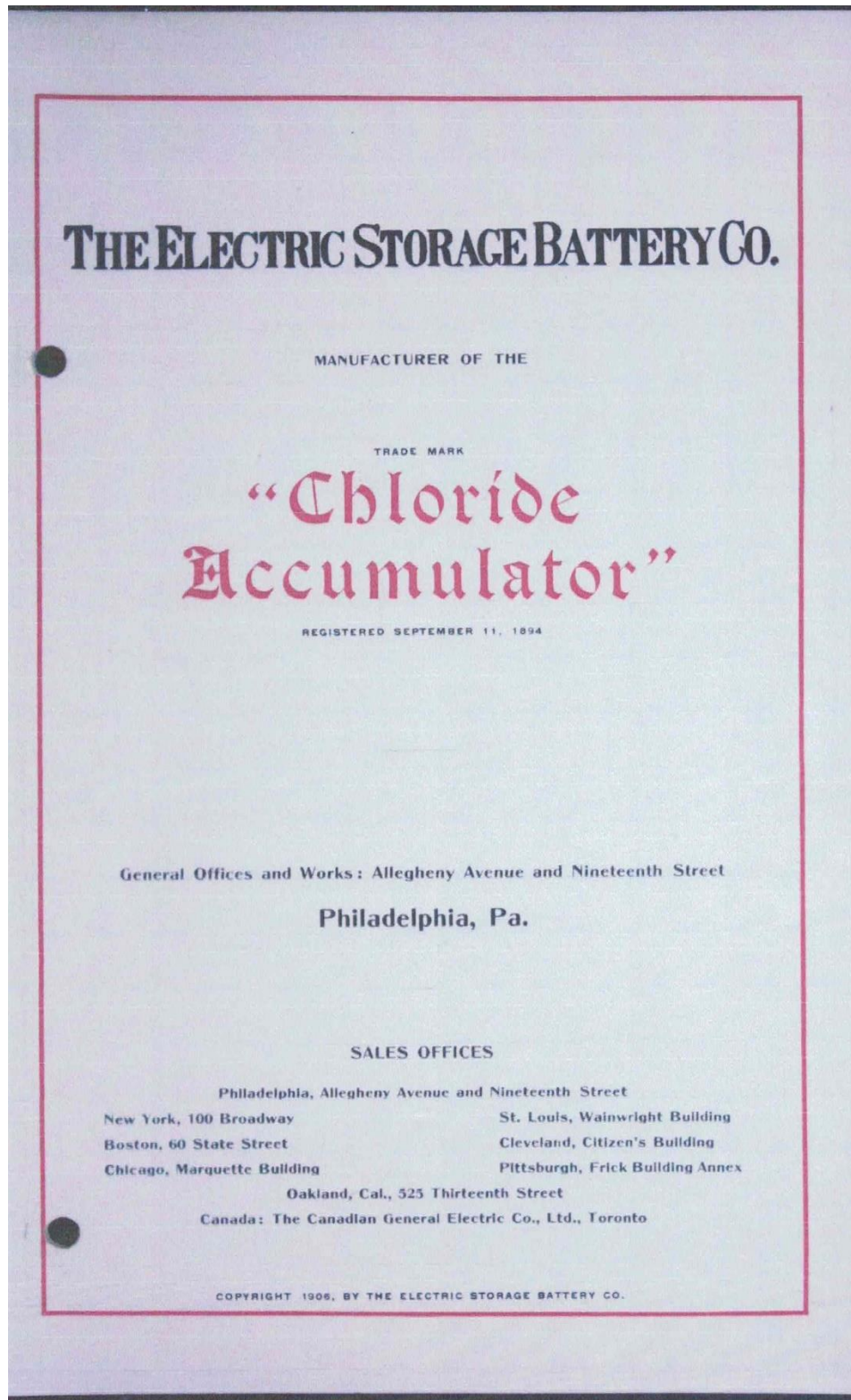

THE ELECTRIC STORAGE BATTERY COMPANY
has acquired all the patents and patent rights concerning
the manufacture of electric storage batteries heretofore
owned or controlled by

The General Electric Company

The Edison Electric Light Company

The Thomson-Houston Electric Company

The Brush Electric Company

The Accumulator Company

The Consolidated Electric Storage Company

The General Electric Launch Company

The Bradbury-Stone Electric Storage Company

The Hopedale Electric Company

The Pumpelly-Sorley Battery Company

The Planté Company

The Accumulatoren-Fabrik Aktien-Gesellschaft

(The Tudor Company)

Thereby securing to itself the sole right to supply, in the
United States and Canada, storage batteries of all the
various important types heretofore developed

THE ELECTRIC STORAGE BATTERY CO.

MANUFACTURER OF THE

TRADE MARK

“Chloride Accumulator”

REGISTERED SEPTEMBER 11, 1894

General Offices and Works : Allegheny Avenue and Nineteenth Street

PHILADELPHIA, PA.

Price List A

1906

Sixth Edition

COPYRIGHT, 1906, BY THE ELECTRIC STORAGE BATTERY CO.

ALLIED COMPANIES

For the Manufacture of the

“Chloride Accumulator”

THE ELECTRIC STORAGE BATTERY CO.

General Offices and Works: Allegheny Avenue and Nineteenth Street
PHILADELPHIA, PA., U. S. A.

The Chloride Electrical Storage Company, Limited

Office: 39 Victoria Street, Westminster, S. W., London, Eng.

Works: Clifton Junction, Manchester, Eng.

Registered Office: Clifton Junction, Manchester, Eng.

Accumulatoren-Fabrik Aktien-Gesellschaft

(The Tudor Company)

Office: Luisenstrasse 31 A, Berlin, N. W., Germany

Works: Hagen, Westphalia

THE acquisition by The Electric Storage Battery Company of all the basic patents and patent rights underlying the manufacture of storage batteries, and the subsequent acquirement of patents and patent rights for new and valuable types, enable this Company to furnish cells adapted to every requirement of standard or special work.

The alliance existing between The Electric Storage Battery Company and the largest manufacturers of storage batteries in England and Germany, secures to this Company the experience of the highest engineering talent available in this special field of electrical manufacture.

The value to the public of this united effort to perfect storage battery practice cannot be overestimated, and The Electric Storage Battery Company's products represent the most modern type of accumulator, possessing the highest efficiency, the longest life and most perfect mechanical methods of construction.

The Electric Storage Battery Company owns the patents covering the applications of boosters, cell switches and other auxiliaries to storage battery installations, and has developed types of such apparatus best suited to meet the requirements of the various conditions under which storage batteries are operated.

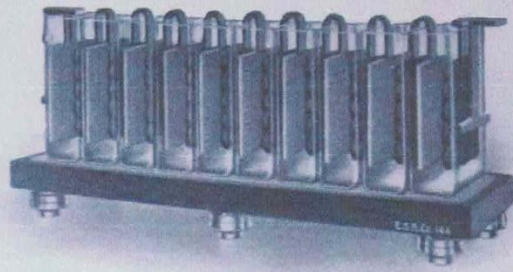

10 "CT" Couples on Sand Tray

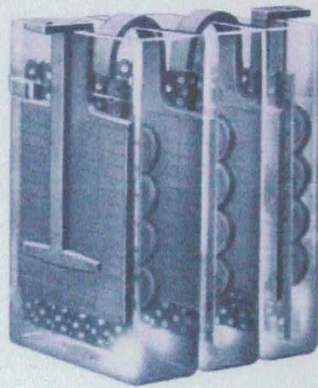

"BT" Couples in Glass Jars

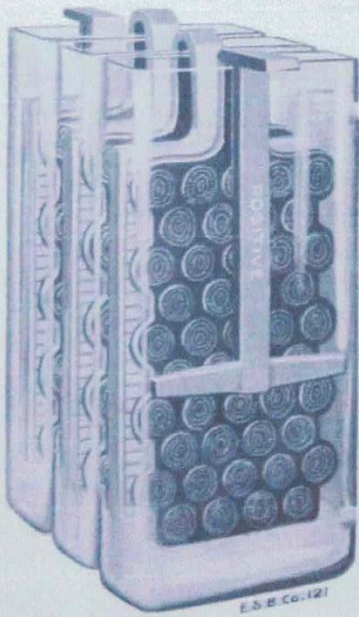

"PT" Couples in Glass Jars

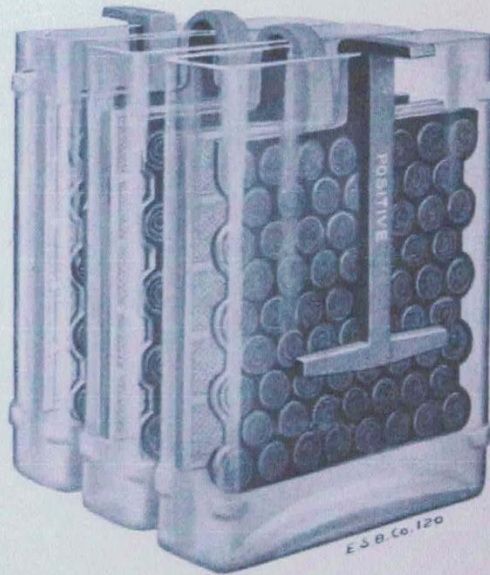

"ET" Couples in Glass Jars

The voltage of cells of all capacities is slightly above two volts on open circuit, and during discharge at the 8-hour rate varies from that point at the beginning to 1.75 volts at the end.

ELEMENTS OF TWO PLATE TYPES

"Chloride Accumulator"					
Type	BT	CT	PT	ET	
Size of plates in inches	4 x 3	5 x 5	8 $\frac{1}{4}$ x 5	7 $\frac{3}{4}$ x 7 $\frac{3}{4}$	
Number of plates	2	2	2	2	
Discharge in amperes	For 8 hours	$\frac{3}{4}$	1 $\frac{1}{2}$	3	4 $\frac{1}{2}$
	5 "	1	2	4 $\frac{1}{4}$	6 $\frac{1}{2}$
	3 "	1 $\frac{1}{2}$	3	6	9
Normal charge rate	$\frac{3}{4}$	1 $\frac{1}{2}$	3	4 $\frac{1}{2}$	
Outside measurement of glass jar, in inches:	Length	1 $\frac{3}{4}$	2 $\frac{1}{4}$	2 $\frac{1}{2}$	2 $\frac{3}{4}$
	Width	3 $\frac{3}{4}$	6 $\frac{1}{4}$	6	8 $\frac{3}{4}$
	Height	6 $\frac{3}{4}$	8	12	11
Outside measurement of rubber jar, in inches	Length	1 $\frac{1}{2}$	2	2	2
	Width	3 $\frac{3}{4}$	5 $\frac{5}{8}$	5 $\frac{5}{8}$	8 $\frac{1}{8}$
	Height	6 $\frac{1}{2}$	8	12 $\frac{1}{4}$	11
THE ELECTRIC STORAGE BATTERY CO.					
Weight of electrolyte in glass jar, in pounds: }	1	2 $\frac{1}{4}$	4 $\frac{1}{2}$	5 $\frac{1}{2}$	
Weight of electrolyte in rubber jar, in pounds: }	$\frac{1}{2}$	2	2 $\frac{1}{2}$	4 $\frac{3}{4}$	
Weight of cell complete, with electrolyte in rubber jar, in pounds: }	2 $\frac{1}{2}$	5 $\frac{3}{4}$	9 $\frac{3}{4}$	14 $\frac{1}{4}$	
Height of cell to top of lug, in inches,	7	8 $\frac{1}{4}$	12 $\frac{1}{4}$	11 $\frac{5}{8}$	
Price, element only \$	0.90	1.75	2.60	3.50	
Price glass jar, extra \$	0.25	0.35	0.60	0.75	
Price, rubber jar and cover, extra . \$	0.65	1.10	1.75	2.05	

N. B.—In ordering Elements, or parts thereof, specify whether Intended for glass or rubber jars. See pages 27 and 28 for prices of Connectors, Electrolyte, etc.

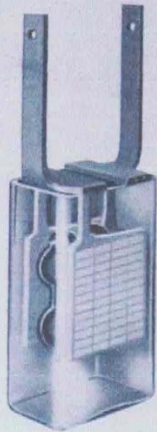

Type "B" 3 Plates in Glass Jar

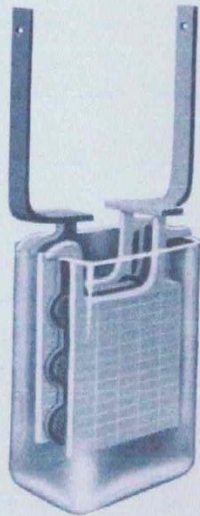

Type "C" 3 Plates in Glass Jar

ELEMENTS OF TYPES "B" AND "C"

"Chloride Accumulator"					
TYPE	B	C			
Size of plate in inches	3 x 3	4 $\frac{3}{8}$ x 4			
Number of plates	3	3	5	7	
Discharge in amperes	For 8 hours	$\frac{5}{8}$	1 $\frac{1}{4}$	2 $\frac{1}{2}$	3 $\frac{3}{4}$
	5 "	$\frac{7}{8}$	1 $\frac{3}{4}$	3 $\frac{1}{2}$	5 $\frac{1}{4}$
	3 "	1 $\frac{1}{4}$	2 $\frac{1}{2}$	5	7 $\frac{1}{2}$
Normal charge rate	$\frac{5}{8}$	1 $\frac{1}{4}$	2 $\frac{1}{2}$	3 $\frac{3}{4}$	
Outside measurement of glass jar, in inches:	Length	2 $\frac{1}{2}$	3 $\frac{1}{2}$	4 $\frac{1}{4}$	5 $\frac{1}{4}$
	Width	4	5 $\frac{1}{4}$	5 $\frac{1}{4}$	5 $\frac{1}{4}$
	Height	4 $\frac{1}{2}$ 5 $\frac{1}{2}$ 6 $\frac{1}{2}$	7 $\frac{1}{4}$	7 $\frac{1}{4}$	7 $\frac{1}{4}$
Outside measurement of rubber jar, in inches:	Length	1 $\frac{3}{4}$	1 $\frac{3}{4}$	2 $\frac{3}{4}$	3 $\frac{3}{8}$
	Width	3 $\frac{3}{8}$	4 $\frac{1}{2}$	4 $\frac{1}{2}$	4 $\frac{1}{2}$
	Height	5	7	7	7
THE ELECTRIC STORAGE BATTERY CO.					
Weight of electrolyte in glass jar, in pounds:	1 $\frac{3}{4}$	3 $\frac{1}{4}$	4 $\frac{1}{4}$	5 $\frac{1}{2}$	
	1 $\frac{1}{4}$				
Weight of electrolyte in rubber jar, in pounds:	$\frac{1}{2}$	1 $\frac{1}{2}$	2 $\frac{1}{4}$	2 $\frac{3}{4}$	
Weight of cell complete, with electro- lyte in rubber jar, in pounds:	3 $\frac{1}{2}$	6 $\frac{1}{2}$	10	13	
Height of cell to top of lug, in inches:	7 $\frac{1}{2}$	15	15	15	
	9 $\frac{1}{2}$				
	11 $\frac{1}{2}$				
Price, element only \$	1.50	2.25	3.50	5.00	
Price glass jar, extra \$	0.15	0.15	0.25	0.30	
Price, rubber jar and cover, extra \$	0.65	0.95	1.15	1.40	

N. B.—In ordering Elements, or parts thereof, specify whether intended for glass or rubber jars. See pages 27 and 28 for prices of Connectors, Electrolyte, etc.

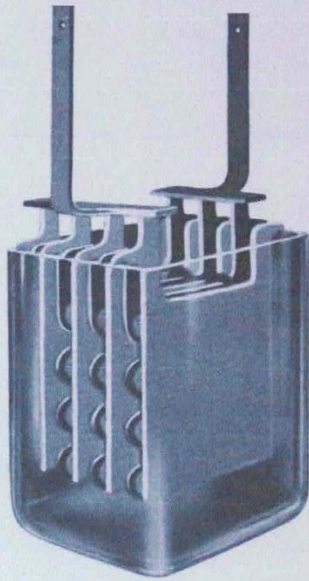

Type "D" 7 Plates in Glass Jar

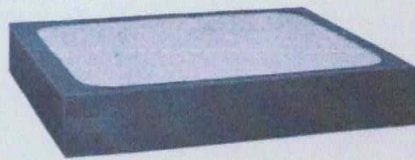

Type "D" Wood Sand Tray

ELEMENTS OF TYPE "D"

Size of Plates, 6 inches by 6 inches

" Chloride Accumulator "							
Number of plates		3	5	7	9	11	13
Discharge in amperes	For 8 hours	2½	5	7½	10	12½	15
	5 "	3½	7	10½	14	17½	21
	3 "	5	10	15	20	25	30
Normal charge rate		2½	5	7½	10	12½	15
Outside measurement of glass jar, in inches:	Length	3¼	4¼	6½	8¼	8¼	11
	Width	7¾	7¾	7¾	8	8	8¼
	Height	9½	9½	9½	9½	9½	9½
Outside measurement of rubber jar, in inches:	Length	1¼	2¼	3¾	5	6¼	7¼
	Width	6½	6¼	6½	6½	6¼	6½
	Height	9	9	9	9	9	9
THE ELECTRIC STORAGE BATTERY CO.							
Weight of electrolyte in glass jar, in pounds:		7½	10½	15	17¼	17¼	21
Weight of electrolyte in rubber jar, in pounds:		2½	3¼	5¼	6¼	7¼	10
Weight of cell complete, with electrolyte in glass jar, in pounds:		20	28	38	48	53	63
Weight of cell complete, with electrolyte in rubber jar, in pounds:		12	18½	24½	32½	39¼	47¼
Height of cell to top of lug, in inches,		18	18	18	18	18	18
Price, element only	\$	3.25	5.00	6.75	8.50	10.25	12.00
Price, glass jar, extra	\$	0.65	0.80	1.20	1.50	1.50	2.25
Price, rubber jar and cover, extra, \$		1.45	1.70	1.90	2.70	3.10	3.95

N. B.—In ordering Elements, or parts thereof, specify whether intended for glass or rubber jars. See pages 27 and 28 for prices of Connectors, Electrolyte, etc.

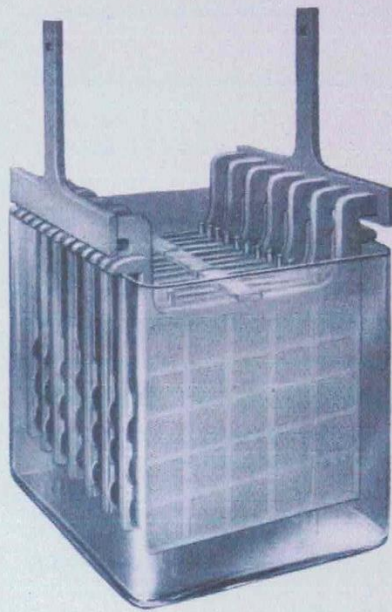

Type "E" 13 Plates in Glass Jar

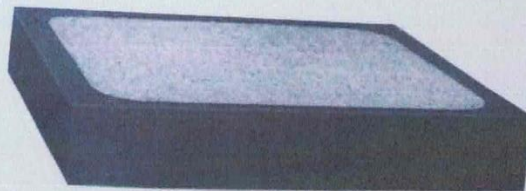

Type "E" Wood Sand Tray

ELEMENTS OF TYPE "E"

Size of Plates, $7\frac{1}{4}$ inches by $7\frac{1}{4}$ inches

		"Chloride Accumulator"					
Number of plates		5	7	9	11	13	15
Discharge in amperes	For						
	8 hours . . .	10	15	20	25	30	35
	5 " . . .	14	21	28	35	42	49
	3 " . . .	20	30	40	50	60	70
1 " . . .	40	60	80	100	120	140	
Normal charge rate		10	15	20	25	30	35
Outside measurement of glass jar, in inches:	Length . . .	$5\frac{1}{2}$	$6\frac{3}{4}$	8	$8\frac{5}{8}$	11	11
	Width . . .	$9\frac{1}{8}$	$9\frac{1}{8}$	$9\frac{1}{8}$	$9\frac{1}{8}$	$9\frac{1}{8}$	$9\frac{1}{8}$
	Height . . .	$11\frac{3}{8}$	$11\frac{3}{8}$	$11\frac{3}{8}$	$11\frac{3}{8}$	$11\frac{3}{8}$	$11\frac{3}{8}$
Outside measurement of rubber jar, in inches:	Length . . .	$2\frac{7}{8}$	$3\frac{7}{8}$	5	$6\frac{1}{8}$	$8\frac{1}{8}$	$8\frac{1}{2}$
	Width . . .	$8\frac{1}{2}$	$8\frac{1}{2}$	$8\frac{1}{2}$	$8\frac{1}{2}$	$8\frac{1}{2}$	$8\frac{1}{2}$
	Height . . .	11	11	11	11	11	11
Outside measurement of all metal tanks, in inches:	Length . . .	$8\frac{3}{4}$	$9\frac{3}{4}$	$11\frac{1}{8}$	$12\frac{3}{8}$	$13\frac{3}{4}$	$15\frac{1}{8}$
	Width . . .	11	11	11	11	11	11
	Height . . .	$12\frac{1}{4}$	$12\frac{1}{4}$	$12\frac{1}{4}$	$12\frac{1}{4}$	$12\frac{1}{4}$	$12\frac{1}{4}$
THE ELECTRIC STORAGE BATTERY CO.							
Weight of electrolyte, in pounds:	In glass . . .	$18\frac{1}{2}$	20	$24\frac{1}{2}$	26	35	34
	" rubber . . .	$5\frac{1}{2}$	8	$10\frac{1}{2}$	12	17	$18\frac{1}{2}$
	" all metal tanks . . .	$27\frac{1}{2}$	$31\frac{1}{2}$	36	40	$44\frac{1}{2}$	49
Weight of cell complete with electrolyte, in pounds:	In glass . . .	49	60	74	$86\frac{1}{2}$	104	112
	" rubber . . .	$29\frac{1}{2}$	$40\frac{1}{2}$	52	63	77	87
	" all metal tanks . . .	85	104	124	136	161	180
Height of cell to top of lug, in inches:	In glass . . .	20	20	20	20	20	20
	" rubber . . .	$12\frac{1}{2}$	$12\frac{1}{2}$	$12\frac{1}{2}$	$12\frac{1}{2}$	$12\frac{1}{2}$	$12\frac{1}{2}$
	" all metal tanks . . .	16	16	16	16	16	16
Price, element only		\$ 8.25	11.75	15.25	18.75	22.25	25.75
Price, glass jar, extra		\$ 1.20	1.35	1.50	1.75	2.55	2.55
Price, rubber jar and cover, extra		\$ 2.90	3.25	3.75	5.05	5.75	6.10
Price, all metal tank, extra		\$ 10.30	11.35	12.40	13.45	14.50	15.55

N. B.—In ordering Elements, or parts thereof, specify whether intended for glass or rubber jars or tanks. See pages 27 and 28 for prices of Connectors, Electrolyte, etc.



Type "F" 15 Plates in all Metal Tank

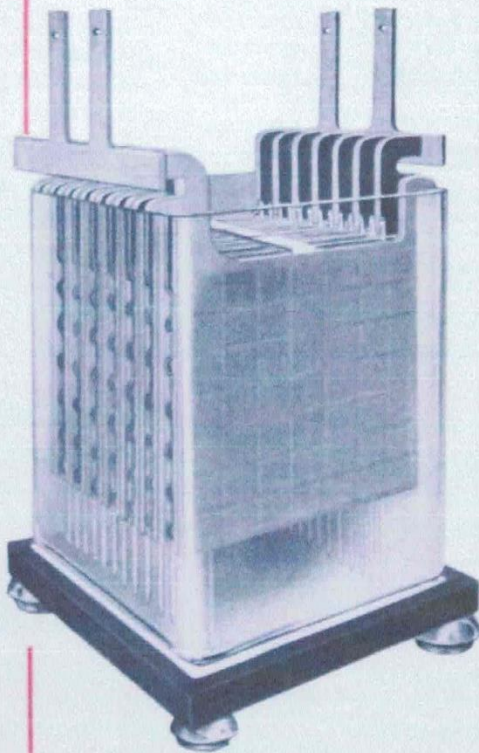

Type "F" 15 Plates in Glass Jar



Type "F" 15 Plates in Glass Tank

ELEMENTS OF TYPE "F"

Size of Plates, 11 inches by 10½ inches

"Chloride Accumulator"											
Number of plates	9	11	13	15	17	19	21	23	25	27	
Discharge in amperes:	For 8 hours	40	50	60	70	80	90	100	110	120	130
	5 "	56	70	84	98	112	126	140	154	168	182
	3 "	80	100	120	140	160	180	200	220	240	260
	1 "	160	200	240	280	320	360	400	440	480	520
Normal charge rate	40	50	60	70	80	90	100	110	120	130	
Outside measurements of glass jar, in inches:	Length	9	10½	10½	12	Old type jars 15½ inches high can be furnished for renewals					
	Width	12½	12½	12½	12½						
	Height	17	17	17	17						
Outside measurements of glass tanks, in inches:	Length			14½		17½		20½			
	Width			13½		13½		13½			
	Height			18½		18½		18½			
Clearance between glass tanks, 2½ and 3½ ins.											
Outside measurements of all metal tanks, in inches:	Length	13½	14½	16½	18½	19½	21½	23½	24½	26½	28½
	Width	15	15	15	15	15	15	15	15	15	15
	Height	17½	17½	17½	17½	17½	17½	17½	17½	17½	17½
Clearance between metal tanks, 2 inches.											
Outside measurements of lead-lined wood tanks, in inches:	Length	13½	15½	16½	18½	20	21½	23½	25	26½	28½
	Width	15	15	15	15	15	15	15	15	15	15
	Height	20½	20½	20½	20½	20½	20½	20½	20½	20½	20½
Clearance between wood tanks, 2 inches.											
THE ELECTRIC STORAGE BATTERY CO.											
Weight of electrolyte, in lbs.:	In glass jars	63	69	67	79						
	In glass tanks			97		121		143			
	In all metal tanks,	95	108	121	134	146	160	172	185	198	212
	In wood tanks	86	99	111	123	133	145	156	168	180	191
Weight of cell complete with electrolyte, in lbs.:	In glass jars	174½	206	227	260						
	In glass tanks			279		352		422			
	In all metal tanks,	256	297	337	377	416	457	497	537	577	618
	In wood tanks	250	292	332	372	411	452	492	532	573	615
Height of cell, in glass jars, from bottom of insulator to top of lug, in inches:	29½	29½	29½	29½							
Height of cell, in glass tanks, from bottom of insulators to top of bus bar, in inches:			23½		23½		23½				
Height of cell, in all metal tanks, from floor to top of bus bar, double insulation, in inches:	33½	33½	33½	33½	33½	33½	33½	33½	33½	33½	33½
Height of cell, in wood tanks, from floor to top of bus bar, double insulation, in inches:	33½	33½	33½	33½	33½	33½	33½	33½	33½	33½	33½
Price, element only	\$ 30.00	37.50	45.00	52.50	60.00	67.50	75.00	82.50	90.00	97.50	
Price, glass jar, extra	\$ 4.00	4.75	4.75	5.75							
Price, glass tank, extra	\$		6.00		7.05		10.50				
Price, all metal tank, extra	\$ 15.55	16.70	17.85	19.00	20.15	21.30	22.45	23.60	24.75	25.90	
Price, lead-lined wood tank, Ex., \$	13.00	13.85	14.70	15.55	16.40	17.25	18.10	18.95	19.80	20.65	

N. B.—In ordering Elements, or parts thereof, specify whether intended for glass jars, glass tanks, all metal tanks, or wood tanks. See pages 27 and 28 for prices of Connectors, Electrolyte, etc.

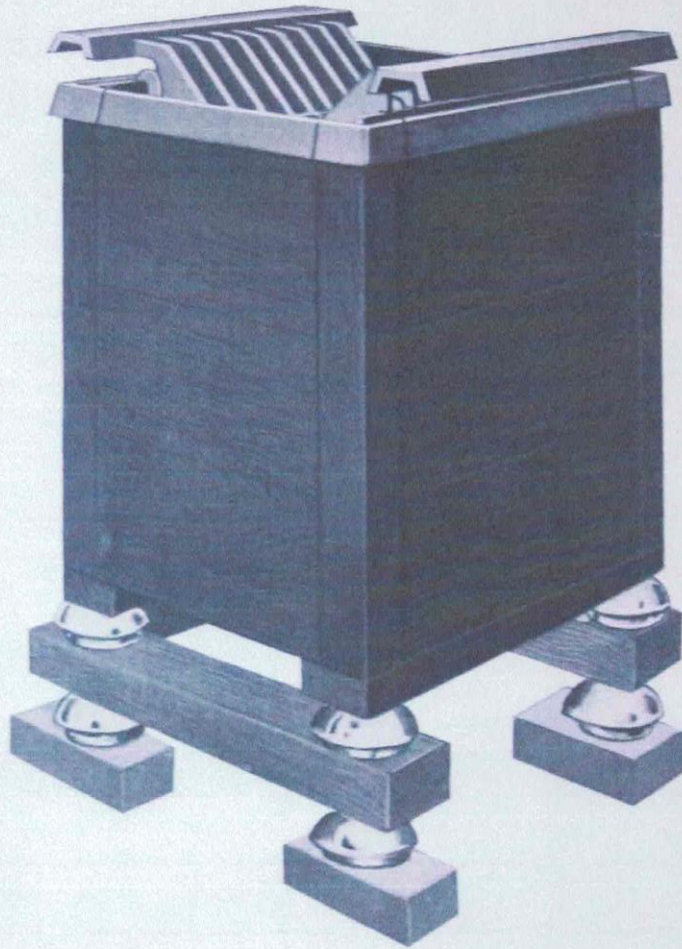

Type "G" 19 Plates in Lead-Lined Wood Tank

ELEMENTS OF TYPE "G"

Size of Plates, 15 5/16 inches by 15 5/16 inches. Clearance between tanks, 2 inches

Number of plates		"Chloride Accumulator"																																			
		11	13	15	17	19	21	23	25	27	29	31	33	35	37	39	41	43	45	47	49	51	53	55	57	59	61	63	65	67	69	71	73	75			
For 8 hours		100	120	140	160	180	200	220	240	260	280	300	320	340	360	380	400	420	440	460	480	500	520	540	560	580	600	620	640	660	680	700	720	740			
Discharge in amperes:		140	168	196	224	252	280	308	336	364	392	420	448	476	504	532	560	588	616	644	672	700	728	756	784	812	840	868	896	924	952	980	1008	1036			
		200	240	280	320	360	400	440	480	520	560	600	640	680	720	760	800	840	880	920	960	1000	1040	1080	1120	1160	1200	1240	1280	1320	1360	1400	1440	1480			
		400	480	560	640	720	800	880	960	1040	1120	1200	1280	1360	1440	1520	1600	1680	1760	1840	1920	2000	2080	2160	2240	2320	2400	2480	2560	2640	2720	2800	2880	2960			
Normal charge rate		100	120	140	160	180	200	220	240	260	280	300	320	340	360	380	400	420	440	460	480	500	520	540	560	580	600	620	640	660	680	700	720	740			
Length		15 1/2	16 3/8	18 3/8	20	22 1/2	24 3/8	26	27 3/4	29 3/8	31	32 3/4	34 1/8	36	37 3/4	39 3/8	40 3/4	42 1/4	44 1/8	45 3/4	47 3/8	49 1/4	51 1/8	53 1/4	55 3/8	57 3/4	59 3/8	61 1/4	63 3/8	65 3/4	67 3/8	69 3/4	71 3/8	73 3/4			
Width		19 3/8	19 3/8	19 3/8	20 3/8	20 3/8	20 3/8	20 3/8	20 3/8	20 3/8	20 3/8	20 3/8	20 3/8	20 3/8	20 3/8	20 3/8	20 3/8	20 3/8	20 3/8	20 3/8	20 3/8	20 3/8	21 3/8	21 3/8	21 3/8	21 3/8	21 3/8	21 3/8	21 3/8	21 3/8	21 3/8	21 3/8	21 3/8	21 3/8			
Height		26	26	26	26	26 1/2	26 1/2	26 1/2	26 1/2	26 1/2	26 1/2	26 1/2	26 1/2	26 1/2	26 1/2	26 1/2	26 1/2	26 1/2	26 1/2	26 1/2	26 1/2	26 1/2	26 1/2	26 1/2	26 1/2	26 1/2	26 1/2	26 1/2	26 1/2	26 1/2	26 1/2	26 1/2	26 1/2	26 1/2			
THE ELECTRIC STORAGE BATTERY CO.																																					
Weight of electrolyte, in pounds,		188	210	231	253	274	296	317	338	360	381	403	424	446	467	489	510	532	553	576	596	618	639	661	682	704	725	747	768	790	811	833	854	876			
Weight of cell, complete, with electrolyte, in lead-lined wood tank, in pounds:		568	645	719	788	825	1006	1085	1165	1266	1347	1427	1507	1588	1668	1748	1841	1922	2005	2086	2168	2249	2330	2415	2507	2597	2641	2724	2806	2889	2971	3053	3135	3217	3300		
Height of cell from floor to top of bus-bar, for double insulation, in inches:		38 1/2	38 1/2	38 1/2	40 1/2	40 1/2	40 1/2	40 1/2	40 1/2	40 1/2	40 1/2	40 1/2	40 1/2	40 1/2	40 1/2	40 1/2	40 1/2	41 1/2	41 1/2	41 1/2	41 1/2	41 1/2	41 1/2	41 1/2	41 1/2	41 1/2	41 1/2	41 1/2	41 1/2	41 1/2	41 1/2	41 1/2	41 1/2	41 1/2			
Price, element only		\$ 75.00	\$ 80.00	\$ 85.00	\$ 90.00	\$ 95.00	\$ 100.00	\$ 105.00	\$ 110.00	\$ 115.00	\$ 120.00	\$ 125.00	\$ 130.00	\$ 135.00	\$ 140.00	\$ 145.00	\$ 150.00	\$ 155.00	\$ 160.00	\$ 165.00	\$ 170.00	\$ 175.00	\$ 180.00	\$ 185.00	\$ 190.00	\$ 195.00	\$ 200.00	\$ 205.00	\$ 210.00	\$ 215.00	\$ 220.00	\$ 225.00	\$ 230.00	\$ 235.00			
Price, lead-lined wood tank, extra		\$ 18.70	\$ 19.50	\$ 20.40	\$ 21.25	\$ 22.00	\$ 22.85	\$ 23.60	\$ 24.45	\$ 25.20	\$ 26.00	\$ 26.75	\$ 27.50	\$ 28.25	\$ 29.00	\$ 29.75	\$ 30.50	\$ 31.25	\$ 32.00	\$ 32.75	\$ 33.50	\$ 34.25	\$ 35.00	\$ 35.75	\$ 36.50	\$ 37.25	\$ 38.00	\$ 38.75	\$ 39.50	\$ 40.25	\$ 41.00	\$ 41.75	\$ 42.50				

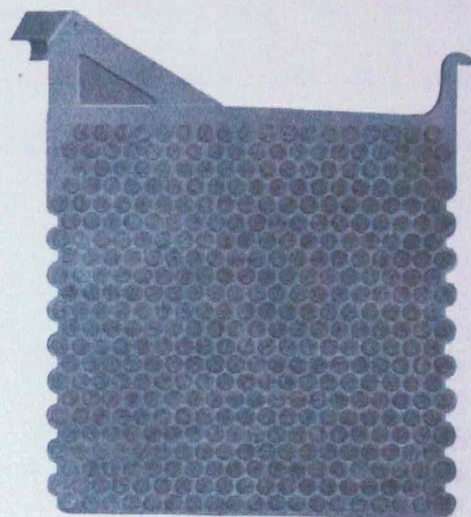

Type "R" Positive Plate

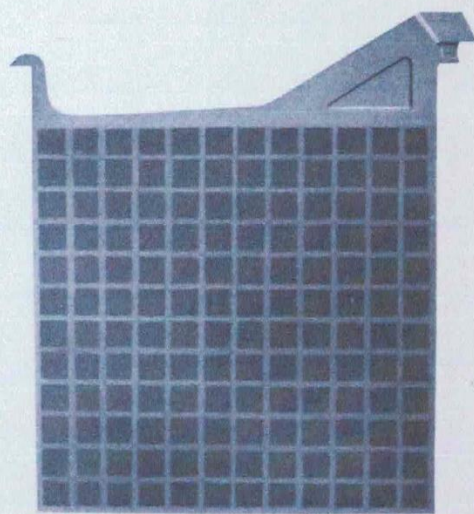

Type "R" Negative Plate

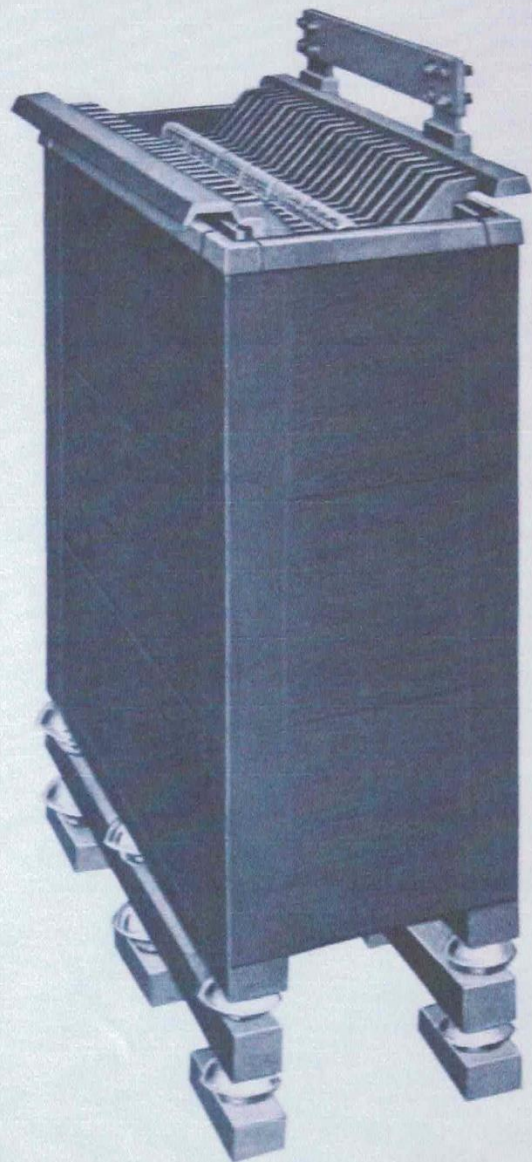

Type "H" 45 Plates in Lead-Lined Wood Tank

ELEMENTS OF TYPE "H"

Size of Plates, 30 ¹/₂ inches by 15 ¹/₈ inches. Clearance between tanks, 2 inches

		21	23	25	27	29	31	33	35	37	39	41	43	45	47	49	51	53	55	57	59	61	63	65	67	69	71	73	75				
Number of plates		400	440	480	520	560	600	640	680	720	760	800	840	880	920	960	1000	1040	1080	1120	1160	1200	1240	1280	1320	1360	1400	1440	1480				
For 8 hours		560	616	672	728	784	840	896	952	1008	1064	1120	1176	1232	1288	1344	1400	1456	1512	1568	1624	1680	1736	1792	1848	1904	1960	2016	2072				
Discharge in amperes:		800	880	960	1040	1120	1200	1280	1360	1440	1520	1600	1680	1760	1840	1920	2000	2080	2160	2240	2320	2400	2480	2560	2640	2720	2800	2880	2960				
1		1600	1760	1920	2080	2240	2400	2560	2720	2880	3040	3200	3360	3520	3680	3840	4000	4160	4320	4480	4640	4800	4960	5120	5280	5440	5600	5760	5920				
Normal charge rate		400	440	480	520	560	600	640	680	720	760	800	840	880	920	960	1000	1040	1080	1120	1160	1200	1240	1280	1320	1360	1400	1440	1480				
Outside meas-	Length	25 ¹ / ₈ , 26 ¹ / ₈	28 ¹ / ₈ , 29 ¹ / ₈	31 ¹ / ₈ , 32 ¹ / ₈	34 ¹ / ₈ , 35 ¹ / ₈	37 ¹ / ₈ , 38 ¹ / ₈	40 ¹ / ₈ , 41 ¹ / ₈	43 ¹ / ₈ , 44 ¹ / ₈	46 ¹ / ₈ , 47 ¹ / ₈	49 ¹ / ₈ , 50 ¹ / ₈	52 ¹ / ₈ , 53 ¹ / ₈	55 ¹ / ₈ , 56 ¹ / ₈	58 ¹ / ₈ , 59 ¹ / ₈	61 ¹ / ₈ , 62 ¹ / ₈	64 ¹ / ₈ , 65 ¹ / ₈	67 ¹ / ₈ , 68 ¹ / ₈	70 ¹ / ₈ , 71 ¹ / ₈	73 ¹ / ₈ , 74 ¹ / ₈	76 ¹ / ₈ , 77 ¹ / ₈	79 ¹ / ₈ , 80 ¹ / ₈	82 ¹ / ₈ , 83 ¹ / ₈	85 ¹ / ₈ , 86 ¹ / ₈	88 ¹ / ₈ , 89 ¹ / ₈	91 ¹ / ₈ , 92 ¹ / ₈	94 ¹ / ₈ , 95 ¹ / ₈	97 ¹ / ₈ , 98 ¹ / ₈	100 ¹ / ₈ , 101 ¹ / ₈	103 ¹ / ₈ , 104 ¹ / ₈	106 ¹ / ₈ , 107 ¹ / ₈				
ument of	Width	21 ¹ / ₈	21 ¹ / ₈	21 ¹ / ₈	21 ¹ / ₈	21 ¹ / ₈	21 ¹ / ₈	21 ¹ / ₈	21 ¹ / ₈	21 ¹ / ₈	21 ¹ / ₈	21 ¹ / ₈	21 ¹ / ₈	21 ¹ / ₈	21 ¹ / ₈	21 ¹ / ₈	21 ¹ / ₈	21 ¹ / ₈	21 ¹ / ₈	21 ¹ / ₈	21 ¹ / ₈	21 ¹ / ₈	21 ¹ / ₈	21 ¹ / ₈	21 ¹ / ₈	21 ¹ / ₈	21 ¹ / ₈	21 ¹ / ₈	21 ¹ / ₈	21 ¹ / ₈			
tank	Height	48 ¹ / ₈	48 ¹ / ₈	48 ¹ / ₈	48 ¹ / ₈	48 ¹ / ₈	48 ¹ / ₈	48 ¹ / ₈	48 ¹ / ₈	48 ¹ / ₈	48 ¹ / ₈	48 ¹ / ₈	48 ¹ / ₈	48 ¹ / ₈	48 ¹ / ₈	48 ¹ / ₈	48 ¹ / ₈	48 ¹ / ₈	48 ¹ / ₈	48 ¹ / ₈	48 ¹ / ₈	48 ¹ / ₈	48 ¹ / ₈	48 ¹ / ₈	48 ¹ / ₈	48 ¹ / ₈	48 ¹ / ₈	48 ¹ / ₈	48 ¹ / ₈	48 ¹ / ₈			
inches:																																	
THE ELECTRIC STORAGE BATTERY CO.																																	
Weight of electrolyte, in pounds,		583	625	668	711	754	797	840	883	926	969	1012	1055	1098	1140	1182	1225	1268	1311	1354	1397	1440	1484	1527	1570	1613	1655	1698	1741				
Weight of cell, complete with electrolyte, in lead-lined tank, in pounds:		1907	2121	2335	2549	2763	2977	3191	3405	3619	3833	4047	4261	4475	4689	4903	5117	5331	5545	5759	5973	6187	6401	6615	6829	7043	7257	7471	7685	7899	8113		
Height of cell, from floor to top of bus-bar, double insulation, in inches:		62 ¹ / ₈	62 ¹ / ₈	62 ¹ / ₈	62 ¹ / ₈	62 ¹ / ₈	62 ¹ / ₈	62 ¹ / ₈	62 ¹ / ₈	62 ¹ / ₈	62 ¹ / ₈	62 ¹ / ₈	62 ¹ / ₈	62 ¹ / ₈	62 ¹ / ₈	62 ¹ / ₈	62 ¹ / ₈	62 ¹ / ₈	62 ¹ / ₈	62 ¹ / ₈	62 ¹ / ₈	62 ¹ / ₈	62 ¹ / ₈	62 ¹ / ₈	62 ¹ / ₈	62 ¹ / ₈	62 ¹ / ₈	62 ¹ / ₈	62 ¹ / ₈	62 ¹ / ₈	62 ¹ / ₈		
Price, element only		\$1.00	\$1.00	\$1.00	\$1.00	\$1.00	\$1.00	\$1.00	\$1.00	\$1.00	\$1.00	\$1.00	\$1.00	\$1.00	\$1.00	\$1.00	\$1.00	\$1.00	\$1.00	\$1.00	\$1.00	\$1.00	\$1.00	\$1.00	\$1.00	\$1.00	\$1.00	\$1.00	\$1.00	\$1.00	\$1.00		
Price, lead-lined wood tank		\$3.50	\$3.50	\$3.50	\$3.50	\$3.50	\$3.50	\$3.50	\$3.50	\$3.50	\$3.50	\$3.50	\$3.50	\$3.50	\$3.50	\$3.50	\$3.50	\$3.50	\$3.50	\$3.50	\$3.50	\$3.50	\$3.50	\$3.50	\$3.50	\$3.50	\$3.50	\$3.50	\$3.50	\$3.50	\$3.50	\$3.50	

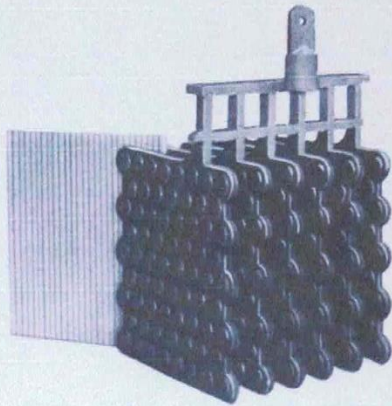

Type "ECS" Positive Group

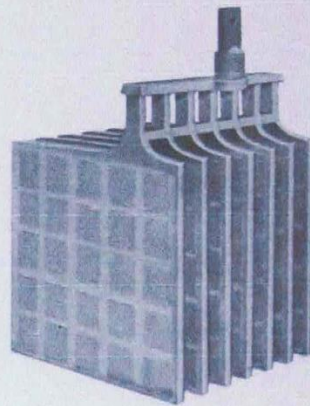

Type "ECS" Negative Group

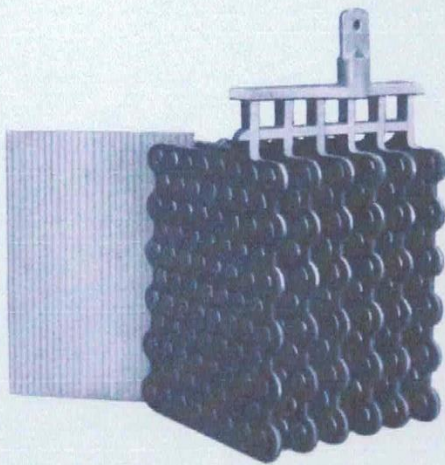

Type "ELS" Positive Group



Type "ELS" Negative Group

Revised by Carl Lightner

ELEMENTS OF CAR-LIGHTING TYPES

Type "E C S"							Type "E L S"						
Size of Plates, 7 $\frac{1}{4}$ inches by 7 $\frac{1}{4}$ inches							Size of Plates, 9 $\frac{1}{8}$ in. by 7 $\frac{1}{8}$ in.						
"Chloride Accumulator"													
Number of plates . . .	5	7	9	11	13	15	5	7	9	11	13	15	
Discharge in amperes	For 8 hours,	10	15	20	25	30	35	12	18	24	30	36	42
	5 "	14	21	28	35	42	49	17	25	33	42	50	59
	3 "	20	30	40	50	60	70	24	36	48	60	72	84
	1 "	40	60	80	100	120	140	48	72	96	120	144	168
Normal charge rate . .	10	15	20	25	30	35	12	18	24	30	36	42	
Outside measurement of rubber jar, in inches:	Length,	3 $\frac{3}{8}$	5 $\frac{3}{8}$	6 $\frac{1}{2}$	7 $\frac{3}{8}$	9 $\frac{1}{2}$	10 $\frac{1}{8}$	3 $\frac{3}{8}$	5 $\frac{3}{8}$	6 $\frac{1}{2}$	7 $\frac{3}{8}$	9 $\frac{1}{2}$	10 $\frac{1}{8}$
	Width,	8 $\frac{1}{8}$	8 $\frac{1}{8}$	8 $\frac{1}{8}$	8 $\frac{1}{8}$	8 $\frac{1}{8}$	8 $\frac{1}{8}$	8 $\frac{1}{8}$	8 $\frac{1}{8}$	8 $\frac{1}{8}$	8 $\frac{1}{8}$	8 $\frac{1}{8}$	8 $\frac{1}{8}$
	Height,	13 $\frac{1}{2}$	13 $\frac{1}{2}$	13 $\frac{1}{2}$	13 $\frac{1}{2}$	13 $\frac{1}{2}$	13 $\frac{1}{2}$	15 $\frac{1}{4}$	15 $\frac{1}{4}$	15 $\frac{1}{4}$	15 $\frac{1}{4}$	15 $\frac{1}{4}$	15 $\frac{1}{4}$
THE ELECTRIC STORAGE BATTERY CO.													
Weight of electrolyte in pounds:	10	14	19	22	27	31	12	17	22	27	32	36	
Weight of cell complete, with electrolyte, in pounds:	39	54	70	85	100	116	47	66	85	104	123	142	
Height of cell from bottom of jar to top of lug, in inches:	15	15	15	15	15	15	16 $\frac{3}{4}$	16 $\frac{3}{4}$	16 $\frac{3}{4}$	16 $\frac{3}{4}$	16 $\frac{3}{4}$	16 $\frac{3}{4}$	
Price, element only	\$ 8.25	11.75	15.25	18.75	22.25	25.75	10.75	15.50	20.25	25.00	29.75	34.50	
Price, rubber jar, extra	\$ 4.30	4.95	5.60	6.25	6.90	7.55	4.70	5.40	6.10	6.80	7.50	8.20	
Price, No. 6 rubber jar, extra:	\$ 6.05	6.95	7.85	8.75	9.65	10.55	6.60	7.60	8.60	9.60	10.60	11.60	
Price, soft rubber lip cover, including soft rubber plug, extra:	\$ 1.75	2.00	2.25	2.50	2.75	3.00	1.75	2.00	2.25	2.50	2.75	3.00	
Price, plain cover, including soft rubber plug, extra:	\$ 0.35	0.45	0.55	0.65	0.75	0.85	0.35	0.45	0.55	0.65	0.75	0.85	

Prices of tanks upon application



"ELS" Rubber Jar and Cover

Two "ELS" Cells Assembled in Crate

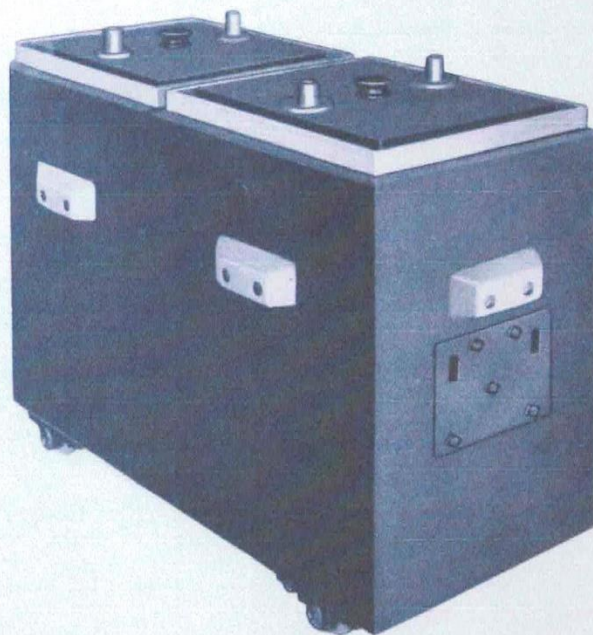

Special Two-Compartment Lead-Lined Tank

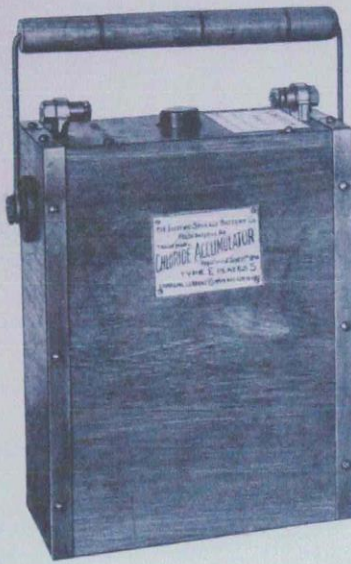

Type 501. Portable Battery

The "Chloride Accumulator"

OF THE PORTABLE TYPE

For portable use, in connection with phonograph, kinoscope, other small motor work, and small electric lamps, the "Chloride Accumulator" is put up in sealed rubber jars, enclosed in a neat hardwood case, provided with handles and suitable connection terminals. Various capacities are furnished, as per table on next page, in which are also given weights, dimensions, normal working rates and prices for batteries complete, ready for immediate use, if ordered so shipped.

Unless otherwise ordered, portable batteries will be shipped filled with electrolyte and charged, ready for service. While the greatest care is used in packing, it is almost impossible to avoid damage to cells of this type when shipped by freight; for short distances it is therefore recommended that shipment be made by express, to insure more care in handling. Where this method is too expensive, it is advisable to forward without electrolyte, which may be ordered to be shipped in a separate vessel, for which a small additional charge is made; the battery to be given the necessary charge upon receipt.

Each cell when discharging gives approximately two volts, and as all the cells in a case are connected together in series, the number of cells multiplied by two will give the approximate voltage between the two outside connectors of each case.

The normal rate is the highest rate in amperes at which the battery should be charged. At this rate the battery will be fully charged in nine hours and discharged in eight hours. At less than normal rates the length of time is increased in both instances and in discharging at more than the normal rate the time is decreased.

With each battery is furnished a folder, giving instructions in detail for its operation and care, which should be followed in order to obtain the most efficient results.

PORTABLE BATTERIES

Catalogue No.	No. of Cells in Case	Type and Number of Plates	Normal Charge and Discharge Rate	Outside Dimensions of Case. Inches			Height Over Lugs, in Inches	Weight Complete	Price Complete Charged	
				Amperes	Length	Width				Height
301	1	"C"	3	1 1/4	3	5 1/2	10 1/2	11 3/4	8	\$5 00
302	2	"	"	1 1/4	4 3/4	5 1/2	10 1/2	11 3/4	14	9 00
303	3	"	"	1 1/4	6 1/2	5 1/2	10 1/2	11 3/4	20	12 50
304	4	"	"	1 1/4	8 1/4	5 1/2	10 1/2	11 3/4	26	16 00
305	5	"	"	1 1/4	10	5 1/2	10 1/2	11 3/4	32	19 00
401	1	"D"	3	2 1/2	3 1/4	7 3/4	12 1/2	13 3/4	15	6 50
402	2	"	"	2 1/2	5 1/4	7 3/4	12 1/2	13 3/4	26	12 00
403	3	"	"	2 1/2	7 1/4	7 3/4	12 1/2	13 3/4	37	16 50
404	4	"	"	2 1/2	9 1/4	7 3/4	12 1/2	13 3/4	48	21 00
405	5	"	"	2 1/2	11 1/4	7 3/4	12 1/2	13 3/4	59	25 00
406	1	"D"	5	5	4 1/4	7 3/4	12 1/2	13 3/4	24	10 00
407	2	"	"	5	7 1/2	7 3/4	12 1/2	13 3/4	43	18 00
408	3	"	"	5	10 3/4	7 3/4	12 1/2	13 3/4	62	26 00
409	4	"	"	5	14	7 3/4	12 1/2	13 3/4	81	32 00
410	5	"	"	5	17 1/4	7 3/4	12 1/2	13 3/4	100	38 00
411	1	"D"	7	7 1/2	5 1/4	7 3/4	12 1/2	13 3/4	33	12 00
412	2	"	"	7 1/2	9 1/4	7 3/4	12 1/2	13 3/4	58	22 00
413	3	"	"	7 1/2	13 1/4	7 3/4	12 1/2	13 3/4	83	30 00
414	4	"	"	7 1/2	17 1/4	7 3/4	12 1/2	13 3/4	108	40 00
415	5	"	"	7 1/2	21 1/4	7 3/4	12 1/2	13 3/4	133	50 00
501	1	"E"	5	10	4 1/4	10	14 1/4	15 1/2	33 1/2	14 50
502	2	"	"	10	7 3/8	10	14 1/4	15 1/2	60	28 00
503	3	"	"	10	10 1/2	10	14 1/4	15 1/2	86 3/4	40 00
504	4	"	"	10	13 5/8	10	14 1/4	15 1/2	113 1/4	50 00
505	5	"	"	10	16 3/4	10	14 1/4	15 1/2	140	60 00
506	1	"E"	7	15	5 1/2	10	14 1/4	15 1/2	42 1/4	18 00
507	2	"	"	15	9 3/4	10	14 1/4	15 1/2	82 1/2	35 00
508	3	"	"	15	14	10	14 1/4	15 1/2	122 3/4	50 00
509	4	"	"	15	17 1/4	10	14 1/4	15 1/2	163	60 00
510	1	"E"	9	20	6 1/2	10	14 1/4	15 1/2	44 3/4	21 00
511	1	"E"	11	25	7 1/2	10	14 1/4	15 1/2	53 1/2	25 00

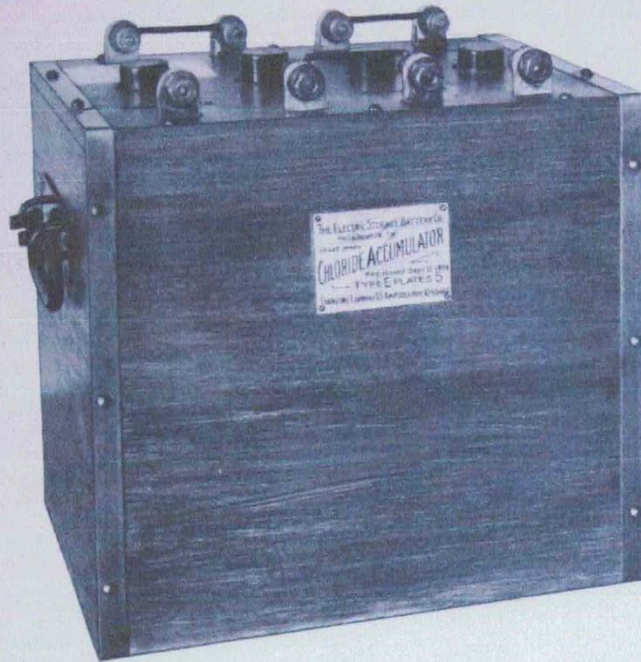

Type 504. Portable Battery
(See page 25)

PACKING CHARGES

In addition to the prices for Elements and Jars, the following net charges will be made for *cases and packing*:

"B" and "BT" Elements,	2 cents each.	
"C" and "CT" Elements,	4 " "	
"D," "PT" and "ET" Elements,	10 cents each.	
"E," "ECS" and "ELS" Elements,	15 cents each.	8 1/2
"F" Elements,	25 cents each.	
"F" Plates (knocked down),	3 cents per plate.	
"G" Plates	5 " "	
"R" Plates	6 " "	
"H" Plates	8 " "	4 1/2
All Metal Tanks, Types E and F, all sizes,	50 cents each.	
Lead-lined Wood Tanks, Type F, all sizes,	50 cents each.	
" " " " " " " " " " " "	G 11 to G 27 inclusive,	75 cents each.
" " " " " " " " " " " "	G 29 to G 39	\$1.00 each.
" " " " " " " " " " " "	G 41 and larger	1.25 " "
" " " " " " " " " " " "	R 25 to R 39	1.25 " "
" " " " " " " " " " " "	R 41 and larger	1.75 " "
" " " " " " " " " " " "	H 21 to H 39	1.50 " "
" " " " " " " " " " " "	H 41 and larger	2.00 " "

Portable Batteries up to 100 pounds weight, 25 cents each; 100 pounds and over, 50 cents each.

Rubber Jars, 5 cents each.

Wood Separators, per 100, H, 30c.; R, 23c.; G, 15c.; F, 7c.; E, 5c.; D and smaller, 3 1/2c.

No charge for packing Glass Jars or Glass Tanks.

The minimum charge for packing, 25 cents.

PRICES

When ordering note the following :

(1.) Prices of Elements do not include Rubber Jars, Glass Jars, Tanks, Electrolyte or Connectors.

(2.) Prices plus packing charges are for delivery *F. O. B.* cars at works, Allegheny Avenue and Nineteenth Street, Philadelphia.

(3.) Carboys will be allowed in full when returned in good condition, charges prepaid, to address furnished by The Electric Storage Battery Company upon application.

We are not liable for damage to goods in transit; our responsibility ceases when we deliver the material in good order to the transportation company; all claims for damage in transit should be made against the carrier.

RENEWALS

Type Elements	Positive Plates	Negative Plates	Rubber Ring Separators	Corrugated and Perforated Rubber Separators	Wood Separators with Dowels
"B T"				\$0.09	
"B"	\$0.60	\$0.45	\$0.05	.05	
"C"	1.00	.70	.06	.07	
"D"	1.26	.85	.07	.13	\$0.03
"E"	2.10	1.40	.09	.21	.04
"E C S"	2.10	1.40			.04
"E L S"	2.80	1.85			.06
"F"	4.00	2.80	.12		.06
"G"	7.85	5.60			.11
"R"	12.25	8.75			.15
"H"	15.70	11.20			.19
"B T" Couples					\$0.90
"C T" "					1.75
"P T" "					2.60
"E T" "					3.50

SUNDRY SUPPLIES

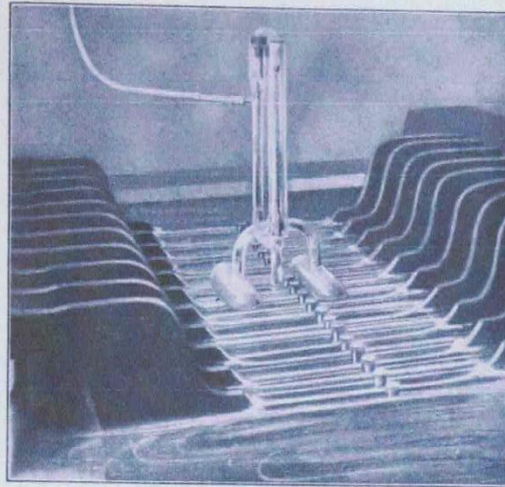

Fig. 1. Automatic Water-Filling Apparatus

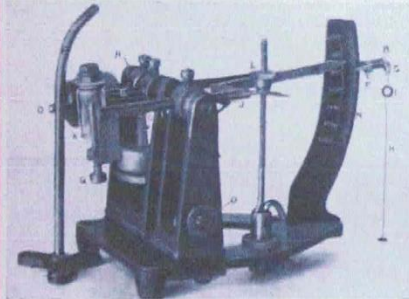

Fig. 2. Signaling Hydrometer



Fig. 3. Recording-Signaling Hydrometer

Automatic Water-Filling Apparatus for Pilot Cells (Fig. 1).

Complete with 3-gallon Glass Reservoir, Stop Valve and Cover (for "F" Cells, G to 39 Plates, R to 29 Plates and H to 29 Plates)	\$10.85
Complete with 5-gallon Glass Reservoir, Stop Valve and Cover (for cells larger than above)	12.60
Each of the above includes 8 feet of Lead Tubing and 16 inches of Rubber Tubing.	

Parts for Automatic Water Filling Apparatus.

Glass Automatic Water Valve, for Type "F," "G" and "R" Cells,	4.50
" " " " "H" " " " " " " " " " " "	5.00
3-gallon Glass Receptacle complete, with Cover, and Stop Valve,	6.00
5 " " " " " " " " " " " " " " " " "	7.25
Rubber Tubing for Connecting the Valve per foot,	.09
Lead Tubing " " "	.03

Signaling Hydrometer complete (Fig. 2)	24.00
Recording-Signaling Hydrometer complete (Fig. 3)	75.00

SUNDRY SUPPLIES (CONCLUDED)

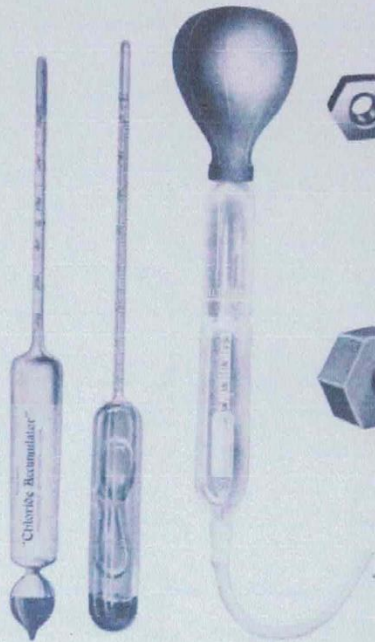

Fig. 1 Fig. 2 Fig. 3

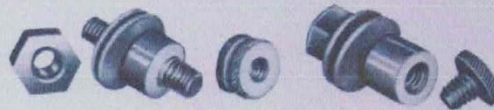

Fig. 4. Binding Posts for Portable Batteries

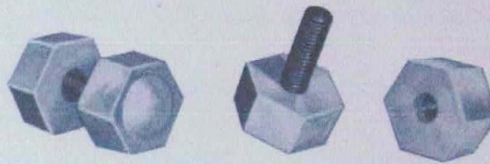

Fig. 5. Bolt Connectors

Hydrometers (Fig. 1)	each,	\$1.50	✓
Compensating Hydrometers (Fig 2)	"	6.00	✓
Hydrometer Syringe (Fig. 3)	"	3.00	✓
Battery Thermometer	"	1.50	✓
Inspection Lamps, Type "G"		4.50	✓
" " " "H"		5.00	✓
Phosphor-Bronze Binding Posts for Portable Batteries (Fig. 4), per set of two60	✓
Bolt Connectors (Fig. 5), Types "B," "C" and "D"	each,	.15	✓
" " " "E" and "F"	"	.20	✓
Sand Trays, wood, for "C" and "D" Elements	"	.40	✓
" " " "E" Elements	"	.45	✓
" " " "F" " in Glass Jars, 9 to 15 inc. "	"	.60	✓
" " " "F" 13 and 17 Elements in Glass Tanks "	"	.80	✓
" " " "F" 21 Elements in Glass Tanks	"	1.00	✓
Sealing Compound	per pound,	.50	✓
Electrolyte	per 100 pounds,	3.00	✓
Carboys	each,	1.50	

See book 2.25 ✓

Entries for 25th Apr

THE ELECTRIC STORAGE BATTERY CO.

General Offices and Works

Allegheny Avenue and Nineteenth Street

PHILADELPHIA

==

SALES OFFICES

PHILADELPHIA

Allegheny Avenue and Nineteenth Street

NEW YORK

100 Broadway

BOSTON

60 State Street

CHICAGO

Marquette Building

PITTSBURGH

Frick Building Annex

ST. LOUIS

Wainwright Building

CLEVELAND

Citizens Building

OAKLAND, CAL.

525 Thirteenth Street

TORONTO, CANADA

The Canadian General Electric Company, Ltd.

==

THIS LIST SUPERSEDES ALL PREVIOUS ISSUES

Prices Subject to Change Without Notice

We are not liable for damage to goods in transit; our responsibility ceases when we deliver the material in good order to the Transportation Company; all claims for damage in transit should be made against the carrier

The following is a presentation made by the Electric Storage Battery Co. at a meeting of the Street Railway Corporation in Detroit MI in October of 1902. It shows a few installations in place across the United States in 1902\

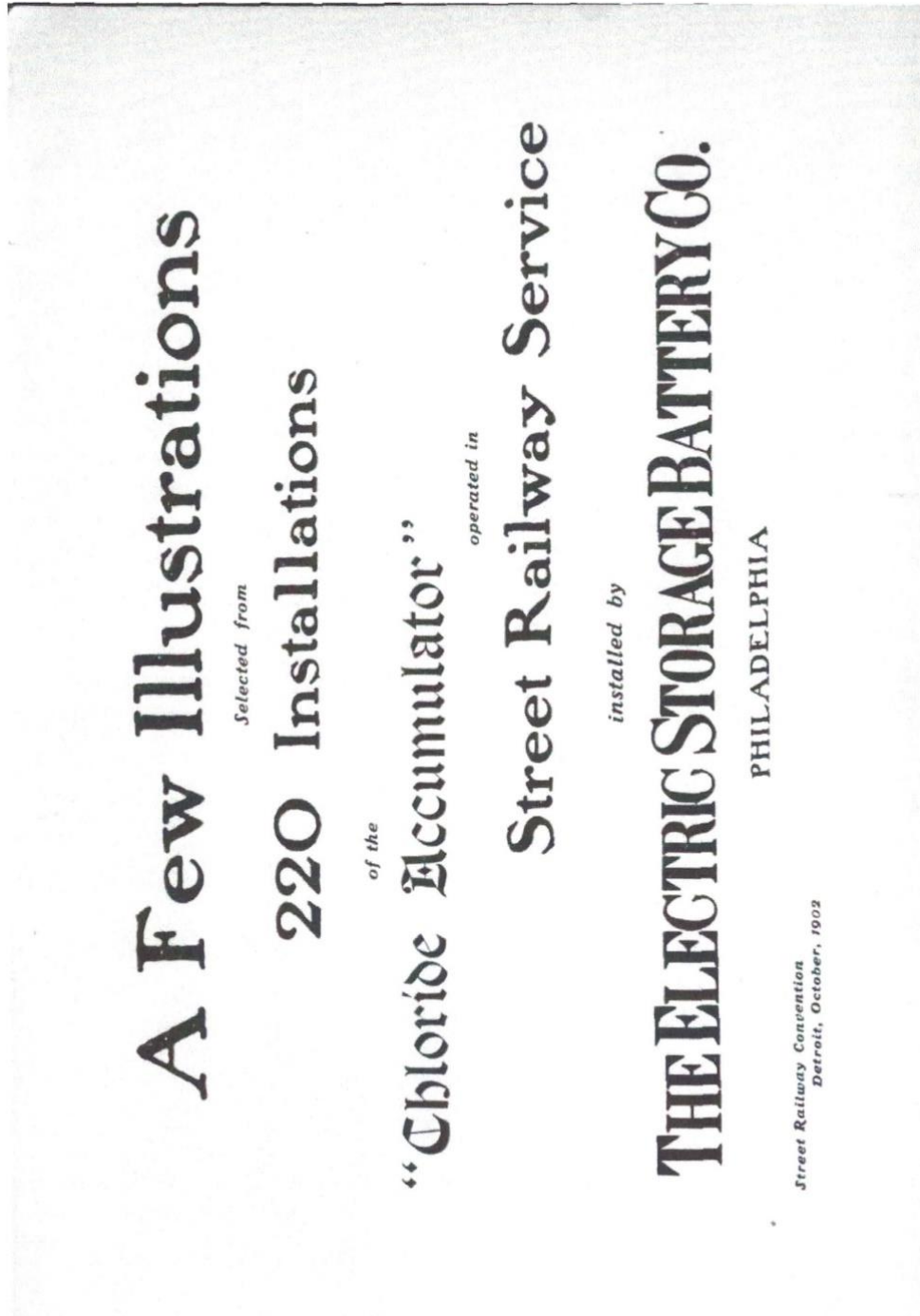

It is hoped that these few illustrations of Railway Battery installations will prove of interest to the members and visitors attending the Street Railway Convention.

The development of the use of "Chloride Accumulators" in connection with the power systems of Electric Street Railways is indicated by the following figures:

Installations to October 1, 1901, 152, aggregating 98,000 K. W. Hours

Installations to October 1, 1902, 220, aggregating 130,000 K. W. Hours

The representatives of the Company will be pleased to furnish information regarding the application of batteries to Street Railway Service.

THE ELECTRIC STORAGE BATTERY CO.

PHILADELPHIA

Detroit, Michigan, October, 1902.

THE ELECTRIC STORAGE BATTERY CO.

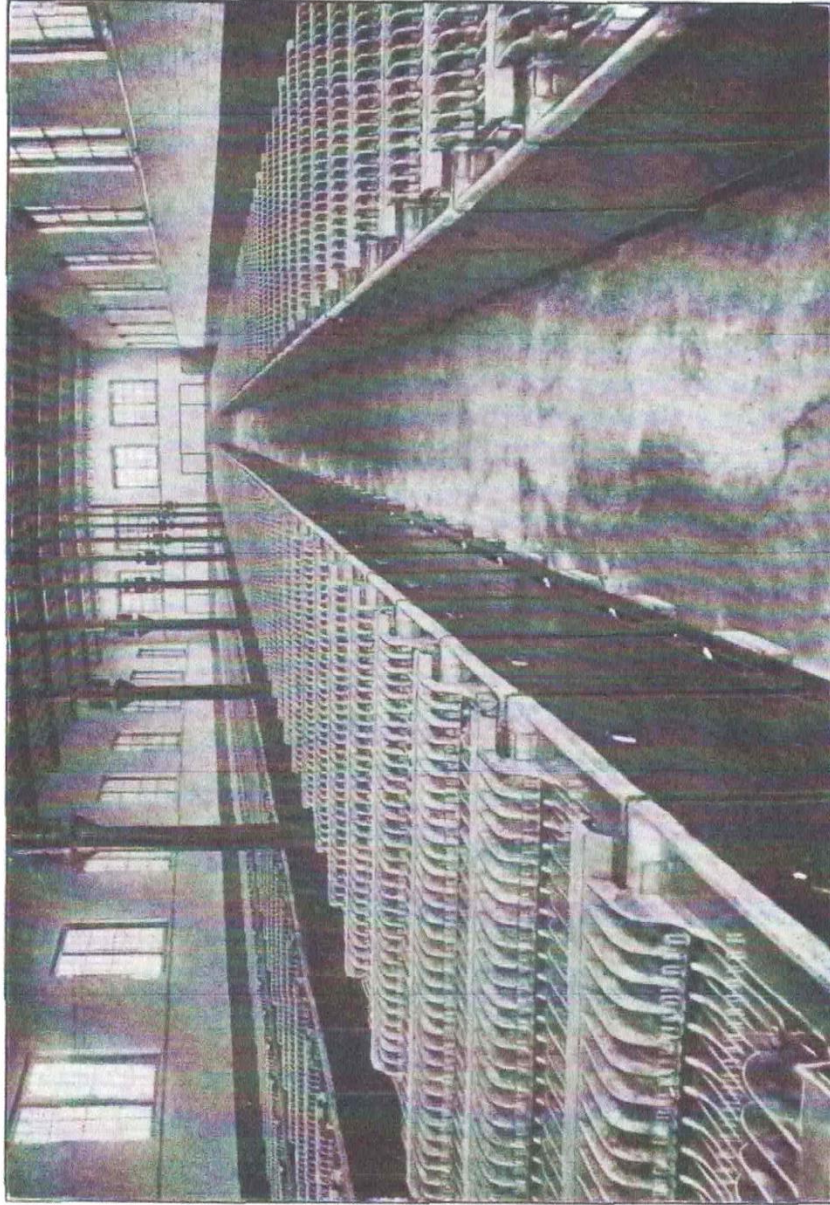

DETROIT UNITED RAILWAY.—BATTERY No. 1

The First Battery of "Chloride Accumulators" installed for the Detroit United Railway is located opposite the Power House and consists of 267 elements, with a capacity of 2000 amperes. It was installed in August, 1900.

THE ELECTRIC STORAGE BATTERY CO.

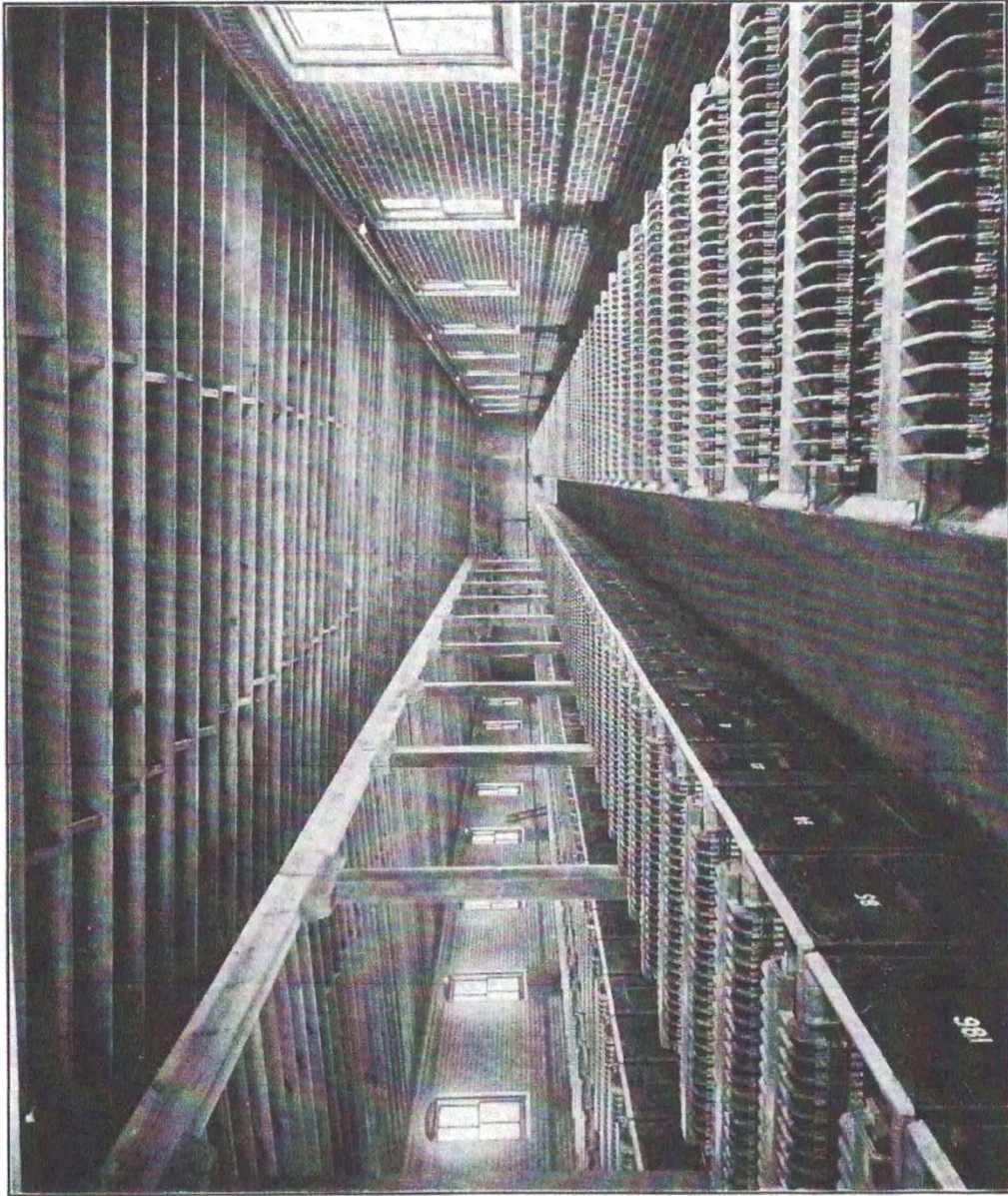

5

DETROIT UNITED RAILWAY.—BATTERY No. 2

The Second Battery of "Chloride Accumulators" installed for the Detroit United Railway is located at the Third Street Sub-Station, a distance of three miles from the Power House, and consists of 250 elements, having a capacity of 2200 amperes. Installed January, 1902.

THE ELECTRIC STORAGE BATTERY CO.

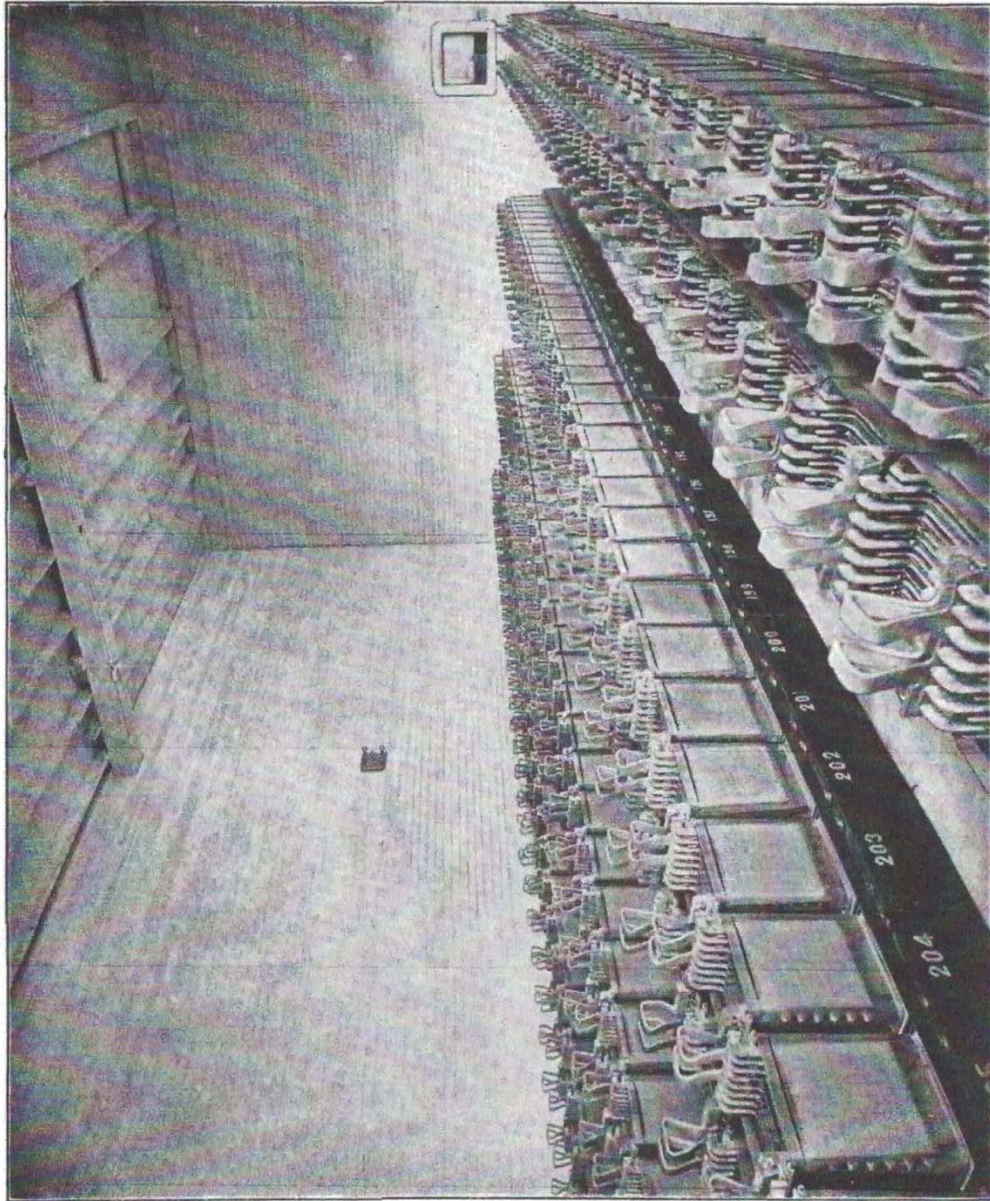

6

DETROIT UNITED RAILWAY—BATTERY No. 3

The Third Battery of "Chloride Accumulators" installed for the Detroit United Railway is located at Ecorse, on the Wyandotte Division, a distance of eleven miles from the Power House, and consists of 276 elements in glass jars, having a capacity of 280 amperes. It was installed in May, 1902.

THE ELECTRIC STORAGE BATTERY CO.

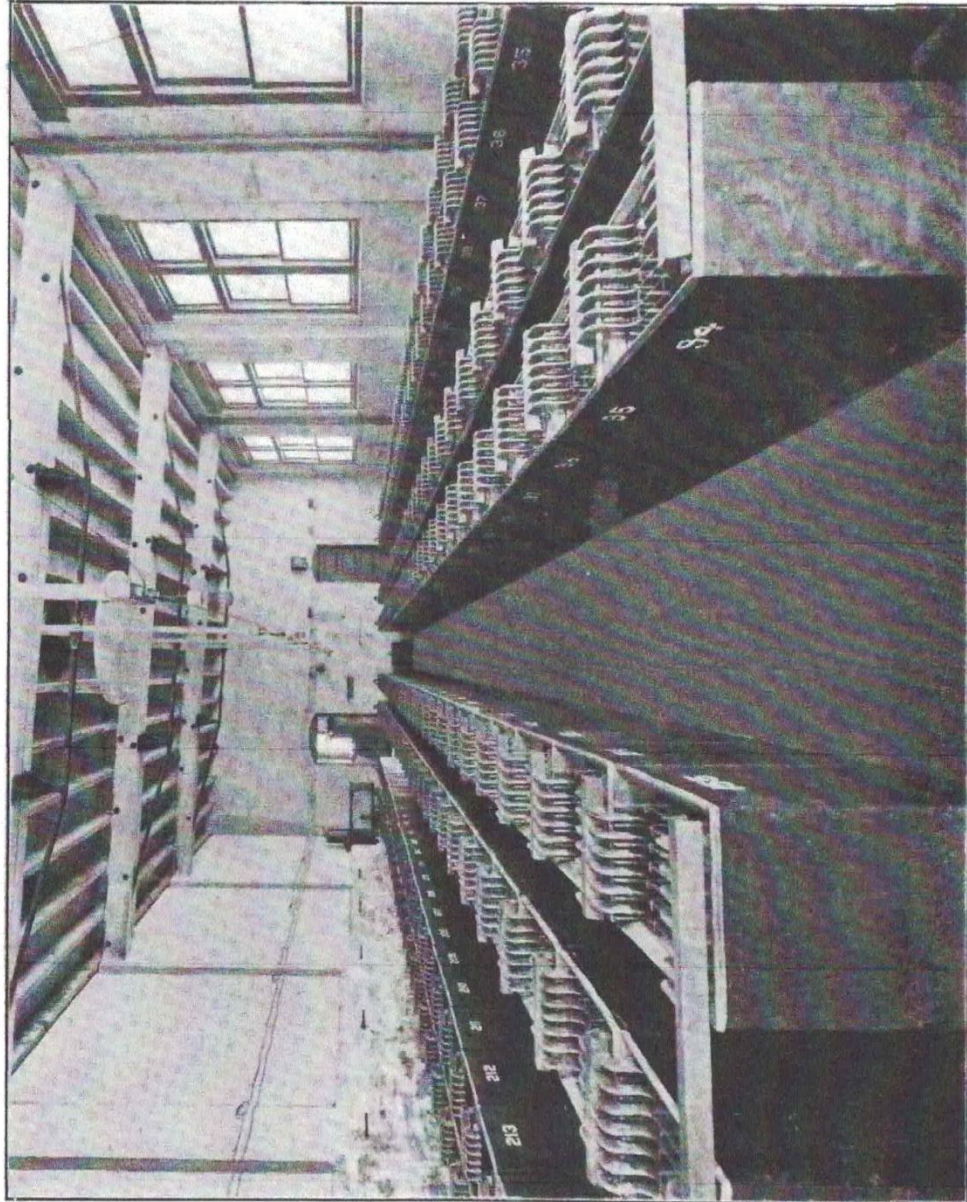

7

PHILADELPHIA RAPID TRANSIT COMPANY

This Battery of "Chloride Accumulators" is the first one installed for the Philadelphia Rapid Transit Company. It is located at Chestnut Hill and was put into operation September, 1896. It consists of 250 elements, having a capacity of 480 amperes. The Philadelphia Rapid Transit Company now operates six Batteries of "Chloride Accumulators."

THE ELECTRIC STORAGE BATTERY CO.

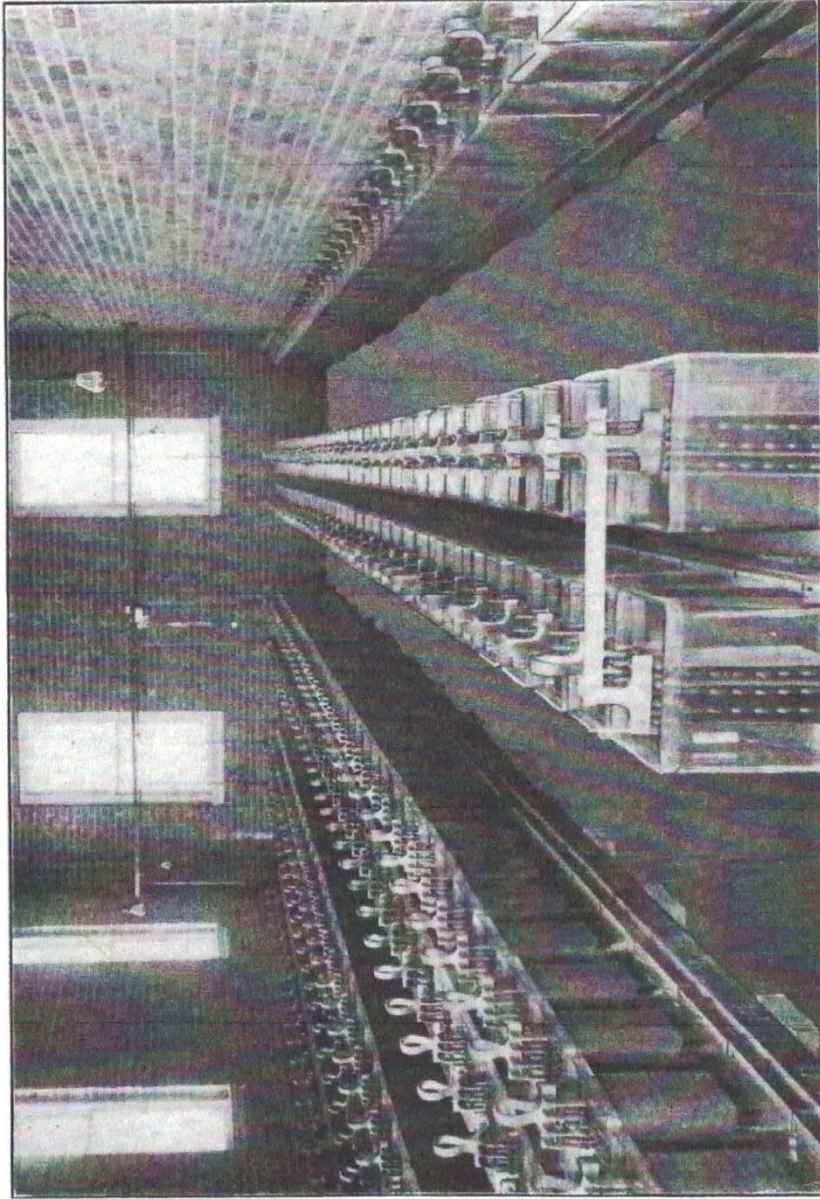

8

CAMDEN INTERSTATE RAILWAY

This Battery, installed for the Camden Interstate Railway, is located at Ironton, Ohio, and consists of 288 elements, having a capacity of 120 amperes. Installation made June, 1902. An increase in the capacity of this Battery, by addition of plates, is now under way. In July, 1902, this Company installed a second Battery, located at Ceresdo, W. Va., having a capacity of 200 amperes.

THE ELECTRIC STORAGE BATTERY CO.



HAMILTON ELECTRIC LIGHT AND CATARACT POWER COMPANY

The above Battery, installed in January, 1901, for the Hamilton Electric Light and Cataract Power Company, of Hamilton, Ontario, consists of 264 cells, having a capacity of 400 amperes. This Battery is operated in conjunction with rotary converters, the main station being operated by water power.

THE ELECTRIC STORAGE BATTERY CO.

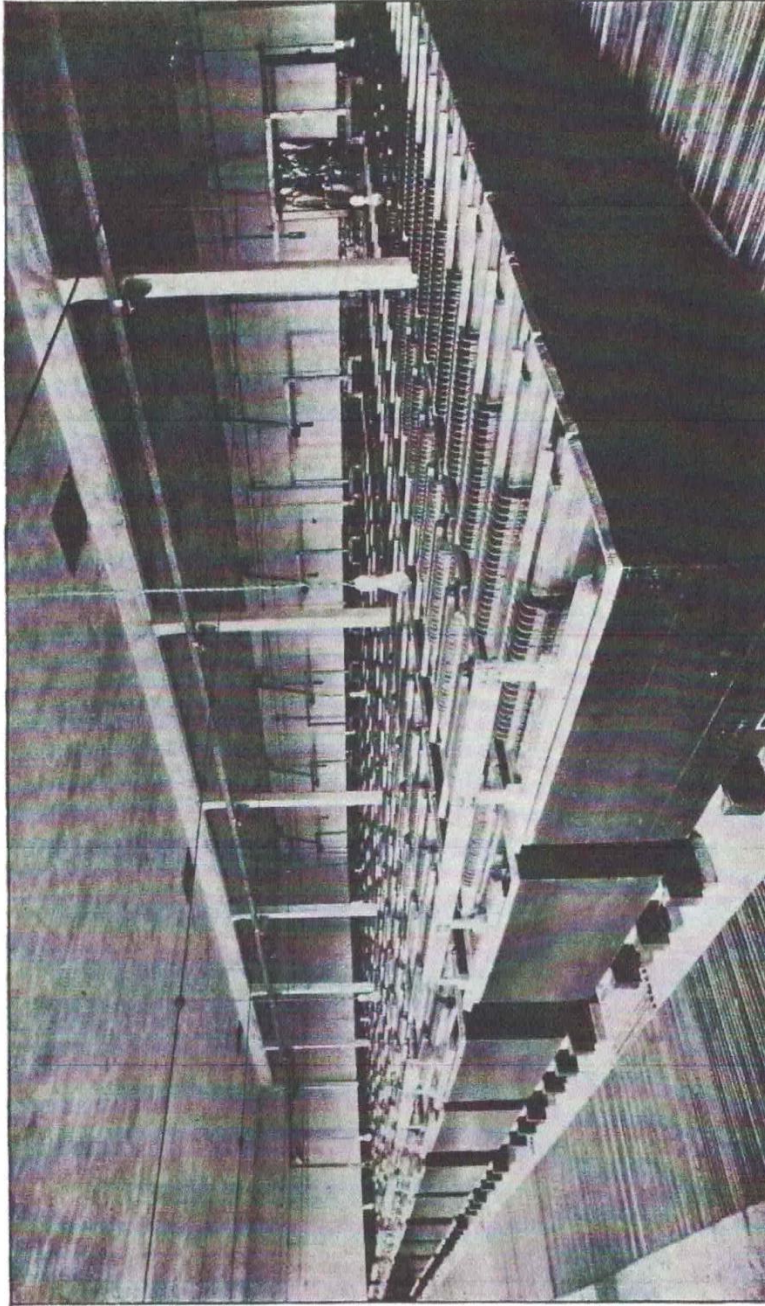

10

BUFFALO RAILWAY COMPANY

The Buffalo Railway Company operates three Batteries of "Chloride Accumulators." The first was installed at Niagara Street, in April, 1898, and consisted of 270 cells, having a capacity of 1360 amperes. This was increased by the addition of plates in June, 1901 to the full capacity of the tanks and now has a capacity of 2480 amperes. The above photograph was taken before increase was made. In July, 1900, the Cold Springs Sub-Station was equipped with 280 cells, and in September, 1900, the Eagle Street Sub-Station with a similar number. The capacity of each of these Sub-Station Batteries is now 2080 amperes.

THE ELECTRIC STORAGE BATTERY CO.

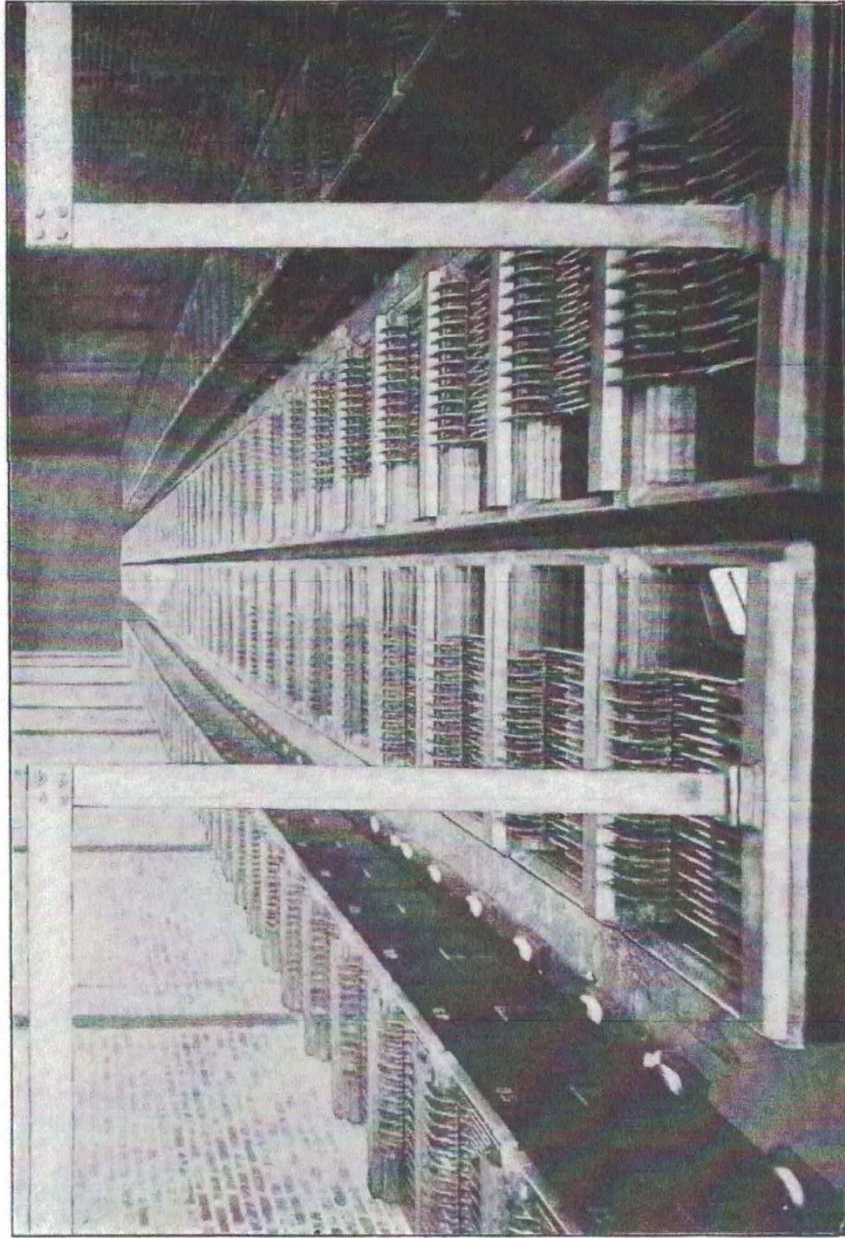

11

THE PITTSBURG RAILWAYS COMPANY

The Pittsburg Railways Company now operates ten Batteries of "Chloride Accumulators." This illustration shows the Battery located at McKeesport, Pa., which was installed in June, 1902, and consists of 264 cells, having a capacity of 960 amperes.

THE ELECTRIC STORAGE BATTERY CO.

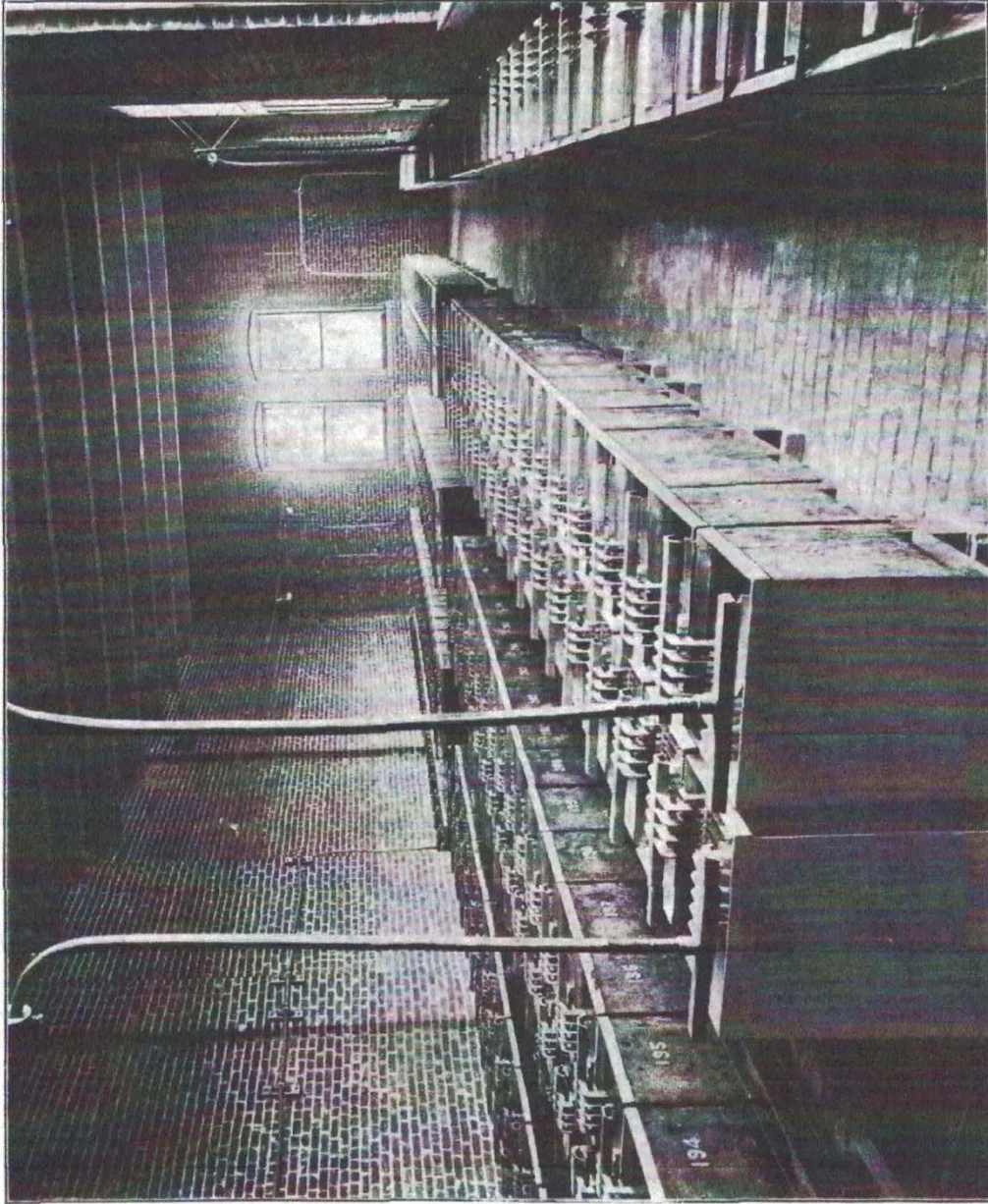

12

THE UNION TRACTION CO., OF INDIANA

The Union Traction Co., of Indiana, operates nine Batteries of "Chloride Accumulators." The Battery illustrated above is located at Elwood, Indiana, and consists of 164 cells, having a capacity of 320 amperes. Installed July, 1900.

THE ELECTRIC STORAGE BATTERY CO.

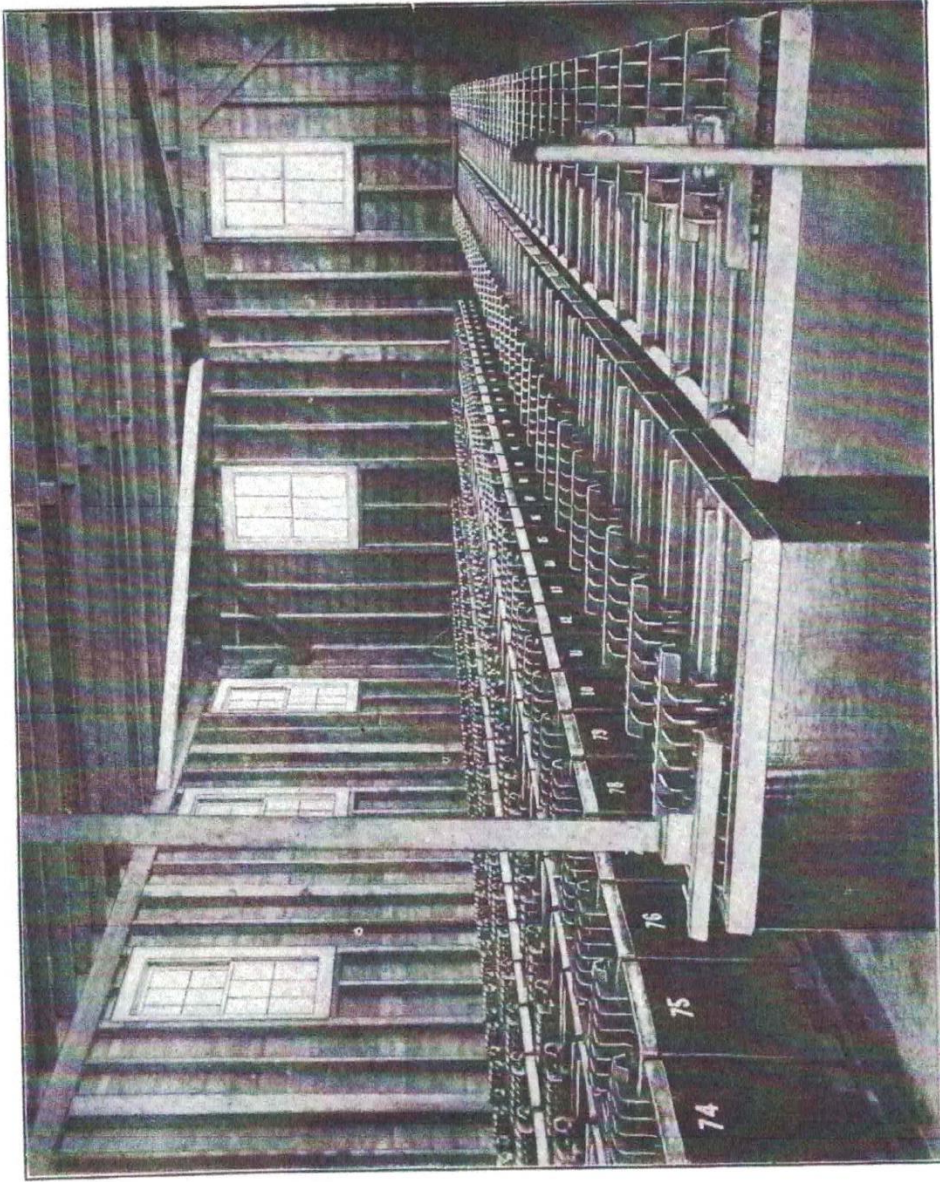

13

THE LEXINGTON AND BOSTON STREET RAILWAY COMPANY

The Lexington and Boston Street Railway Company operates two Batteries of "Chloride Accumulators" located at Concord and South Billerica, Mass., respectively. They were installed in August, 1901, and each consists of 216 elements, having a capacity of 240 amperes. The illustration above is taken from the Concord Installation.

THE ELECTRIC STORAGE BATTERY CO.

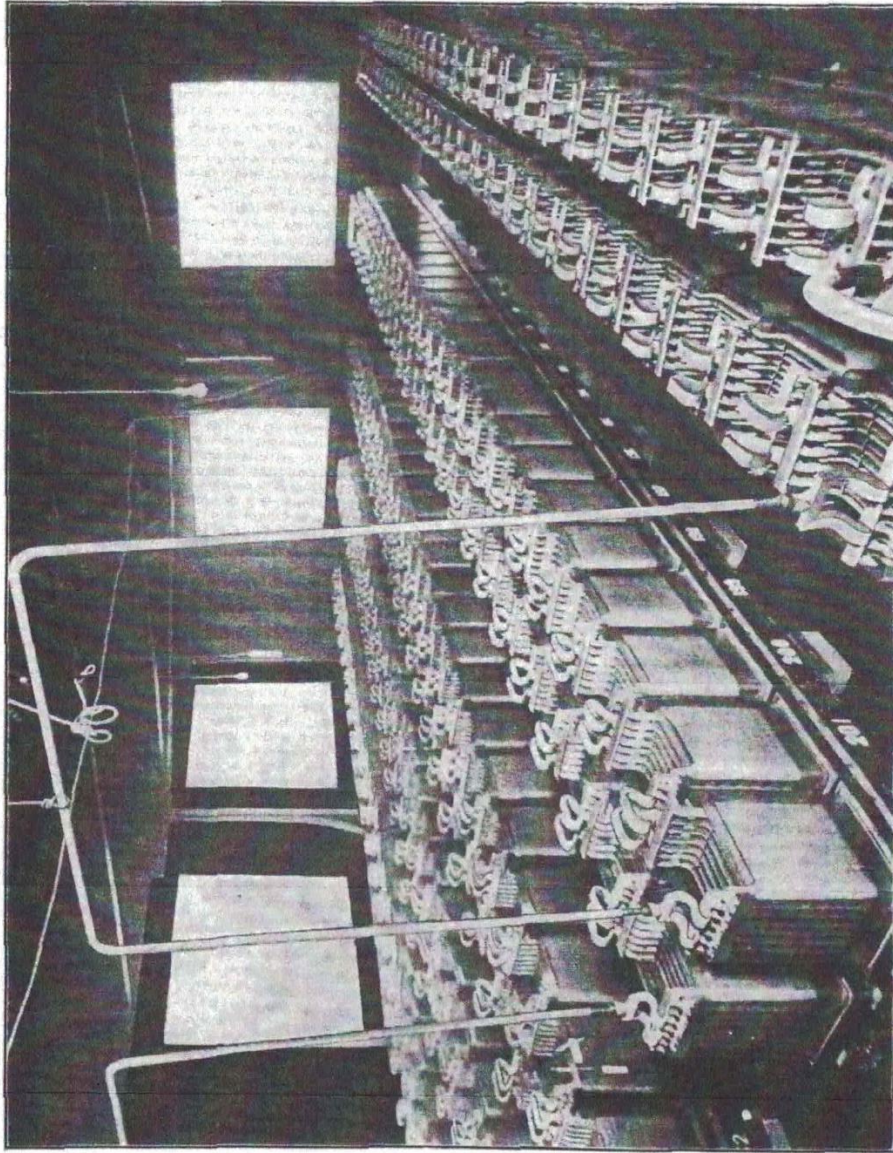

STEUBENVILLE TRACTION AND LIGHT CO.

The above is an illustration of the Battery for the Steubenville Traction and Light Co., installed June, 1902, at Allkamma, Ohio. It consists of 252 cells in glass jars, having a capacity of 240 amperes.

25 APPENDIX G EDISON LALANDE BATTERIES CATALOG LATE 19TH
CENTURY

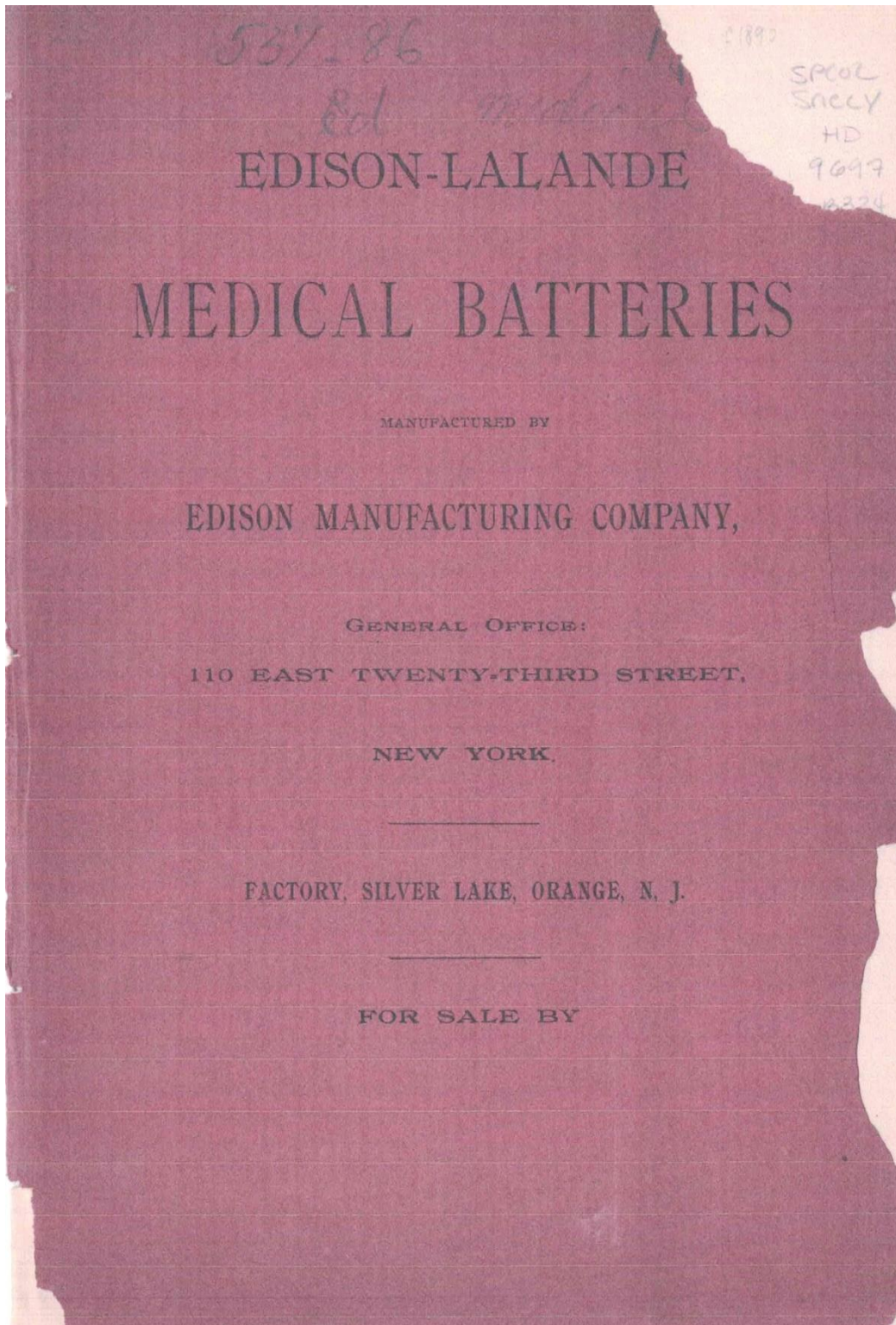

GENERAL DIRECTIONS

FOR

CHARGING.

WHERE it is practicable always make the solution in some large earthenware vessel, and allow it to get quite cold before setting up the battery. Remove any scum from the surface of the solution before pouring on the oil. Stir the solution frequently while the caustic is dissolving.

It is most important that the oxide plates should be entirely submerged in the Caustic Potash solution, so that the top edge of the oxide plate should be at least one inch below the layer of oil.

It is also of vital importance that the oil should not be omitted. When oil is not used creeping salts form, and the life of the battery is reduced fully two-thirds.

Before immersing the plates in the solution, put them in water until they are thoroughly wet. This prevents any oil adhering to them as they pass through. If this is not done a film of oil covers the plates and it is some time before they will work to their full capacity.

DESCRIPTION AND CHEMICAL ACTION OF CELL.

The elements employed in the EDISON-LALANDE cell are zinc, from which the negative current is obtained, and black oxide of copper (Cu. O) the positive current. The exciting liquid is simply a solution of caustic potash. The oxide of copper is obtained by the process of roasting copper turnings; the oxide is then ground into a fine powder and compressed into solid blocks, from which plates of a suitable size for the different cells are cut. These plates are suspended from the cover of the containing vessel, a glass or porcelain jar, by means of a light framework of copper, one end of this framework carrying the binding-post for the positive pole of the battery. On each side of the copper oxide element in the larger type cells (but only on one side in the smaller types), is suspended a rolled zinc plate. The binding-post, which is attached to the zinc plates, has a hard rubber extension yoke, both ends of which fit closely into the grooved sides of copper frame, above cover, to which they are firmly bolted. This prevents any movement in the relative position of the elements, and does away with the necessity of using vulcanite separators to prevent any short circuits occurring in solution. The zincs are amalgamated, and, as in most batteries, the zinc is attacked more vigorously near the top than at the lower part of the plate; the zincs for this cell are made slightly tapering, the thick part being uppermost.

The exciting liquid employed in the battery consists in all types of a 25 per cent. solution of caustic potash in water, or in other words of a solution of one pound of caustic potash in three pounds of water. When the circuit is closed and the cell is put in action, the water is decomposed, the oxygen forming with the zinc, oxide of zinc, which, in turn, combines with the potash to form an exceedingly soluble double salt of zinc and potash, which dissolves as rapidly as it is formed; the hydrogen liberated by the decomposition of the water reduces the copper oxide to metallic copper. This reduced copper is of great purity, and can, of course, be again converted into oxide; the potash is manufactured in sticks, varying in size according to the type of cell, and when the solution is exhausted a renewal is effected by simply placing the sticks in the cell and pouring in the requisite quantity of water. A layer of heavy paraffine oil $\frac{1}{8}$ inch deep is then added to keep out the air and prevent creeping. As for inspection or supervision, so fruitful a source of trouble and expense with other batteries, this cell requires absolutely none. Polarization and local action are, as we have already intimated, entirely absent, the zincs never require cleaning, the solution does not crystallize or creep, and there is no porous pot to crack or lead cap to be converted into white oxide. No fumes or other noxious chemical products are given off by the battery at any time during its existence; in fact, its presence could never be detected by the sense of smell, even in a lady's boudoir, and as for convenience of form and dimensions, what could be better than a cylindrical glass jar containing the two elements suspended from the cover?

A SIMPLER FORM OF CELL IT WOULD BE IMPOSSIBLE TO IMAGINE.

We would also draw the attention of the medical profession to the especial adaptability of the EDISON-LALANDE Battery for medical and surgical work, in that it is the only cell in the market that will fill every need of the physician without recourse to any other make of cell.

The types adapted for Galvanic and Faradic work are "A," "B" and "C," and the models suitable for Cautery, Motor and Diagnostic Lamps are "F," "L" and "M."

CAUTERY BATTERIES.

The EDISON *Cautery Batteries* have been specially designed to meet the large and increasing demand of physicians and surgeons for a reliable battery capable of furnishing a very heavy current for cautery work.

In the F type, illustrated on page 3, the cells, eight in number, are of porcelain, and are neatly placed in a lead-lined polished oak box. The sliding resistance is fitted into a groove in top of box, and is so made that the strength of current can be graduated with the greatest nicety.

The battery, when set up, will last with ordinary use in cautery work for several months, during which time it requires no attention whatever, and when exhausted, the elements can be renewed at a trifling cost.

The cells are closed and the elements do not have to be removed from the solution, as there is practically no action when cells are not in use, and consequently no waste in battery.

It is also equally well adapted for running small motors wound to suit battery, and for lighting electric headlights for throat work and other diagnostic purposes.

Being a primary battery it is entirely independent of any external system, and does not require to be sent to a central station for recharging, as is the case with storage batteries.

The internal resistance is really only a fraction, therefore the whole energy of battery is thrown into the external circuit, and our cautery cells will deliver on actual work from 20 to 30 amperes, according to the size.

Types "L" and "M" Cautery Batteries (see pages 4 and 5) consist of eight round porcelain cells of similar construction to type F, but of larger size, and therefore considerably longer life. These can be placed in a closet or cellar and connected to rheostat in operating room by heavy copper leads, not smaller than No. 8 B. W. G. insulated wire. The above remarks on type "F" battery apply equally to these models.

We wish particularly to call the attention of the medical profession to some of the advantages our batteries have over any other Cautery Battery (either storage or primary), that should prove it indispensable to every well equipped office.

They require absolutely no attention until they need recharging. The current is perfectly constant during the whole life of the battery, so that there is no danger of burning out either lamps or cautery knives. It is always ready for use.

In Volume III. of "A System of Practical Therapeutics," Dr. H. N. Spencer, of St. Louis, in his article on "Chronic Catarrhal Diseases of the Naso pharynx and Consequent Diseases," says: "By far the most perfect battery is the Edison-Lelande. I am indebted to Professor Barker of the University of Pennsylvania, for my first knowledge of this instrument. Its superiority over all others consists in its absolute reliability. I have employed one daily for six months at a time without recharging it."

EDISON CAUTERY BATTERY "F."

CAPACITY, 150 AMPERE-HOURS.

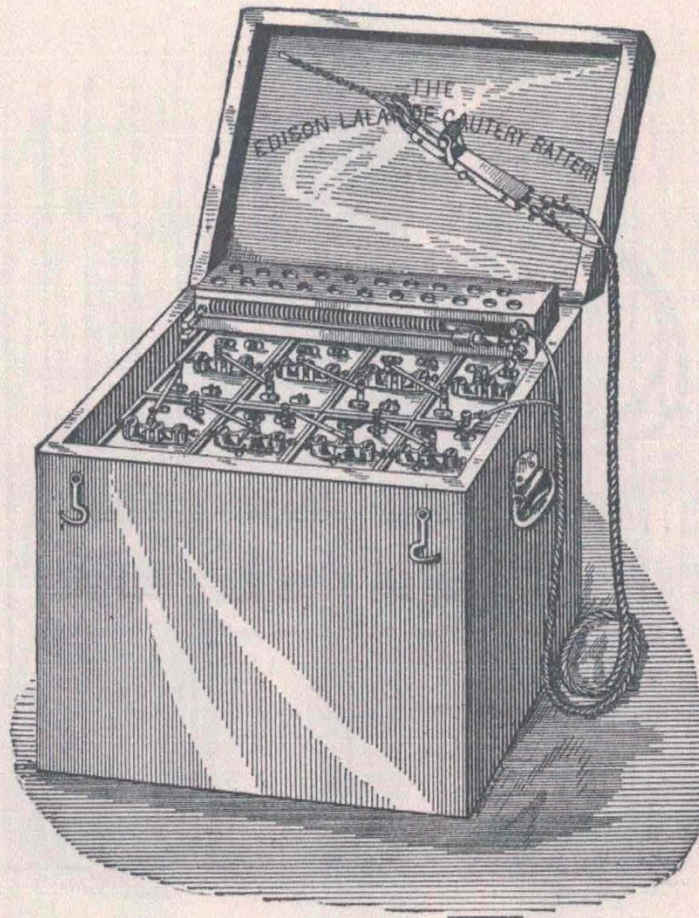

Outfit comprising 8 Porcelain cells type F complete in Polished Oak Case with rheostat, Connecting Strips, Battery Cords, potash and oil..\$50 00
(This price does not include cautery handle.)

Price of Renewal Parts of Each Cell.

3 Zinc Plates (capacity, 1 charge), 16c. each.....	\$0 48
4 Copper Oxide Plates (capacity, 2 charges), 25c. each....	1 00
Can containing 2 sticks Caustic Potash (1 charge).....	18
Bottle Heavy Paraffine Oil sufficient for 1 charge	05
<hr/>	
Total.....	\$1 71

The Copper Oxide Plates will stand 2 charges of Zincs and Potash before being exhausted.

Price of Single F cell complete including charge.....\$4 50

EDISON CAUTERY BATTERY "L."

CAPACITY 300 AMPERE-HOURS.

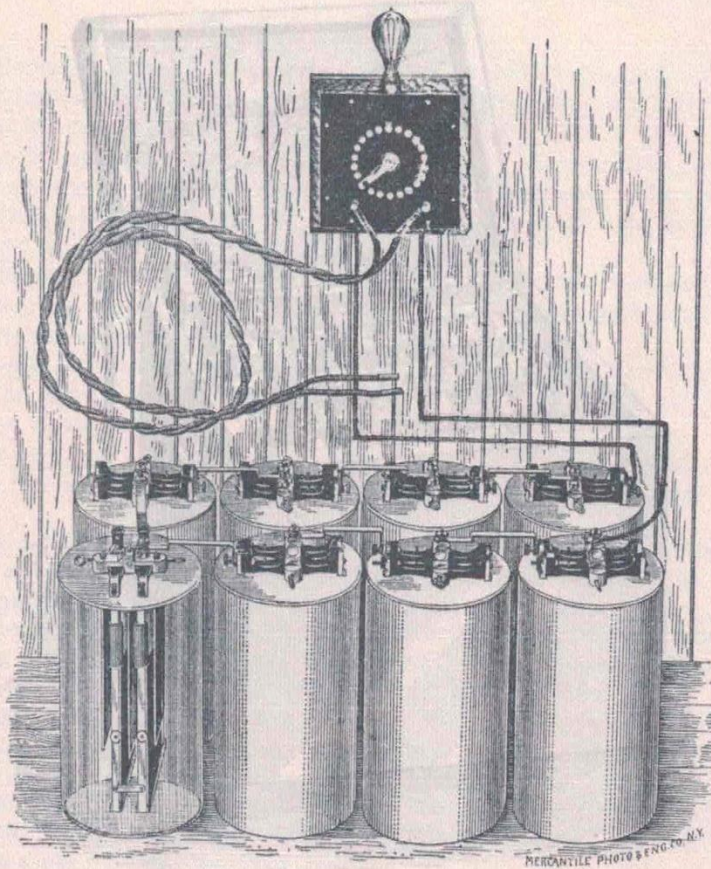

Battery consists of 8 Type "L" Porcelain Cells, to be placed either in the cellar or closet, and which are connected to the rheostat with *heavy* wire leads.

The rheostat is handsomely mounted on a polished oak base to be fastened in any convenient place in the office.

(This battery has twice the life of our Cautery Battery "F.")

Outfit complete comprising 8 L cells, rheostat, cords, necessary connections, wiring, potash and oil... \$45 00

Price of Renewal Parts of each Cell.

3 Zinc Plates (capacity, two charges), 21 cts. each.....	\$0 63
4 Copper Oxide Plates (capacity, two charges), 25 cts. each.....	1 00
Can containing 2 sticks Caustic Potash (one charge).....	28
Bottle heavy Paraffine Oil, sufficient for one charge..	05
Total.....	\$1 96

The oxide plates and zincs in this cell will stand one renewal of solution before being exhausted.

Price of single L cell complete including charge.....\$4 50

Stained and varnished lead lined oak box mounted on castors to hold 8 Type L cells... 4 50

EDISON CAUTERY BATTERY "M."

CAPACITY, 600 AMPERE-HOURS

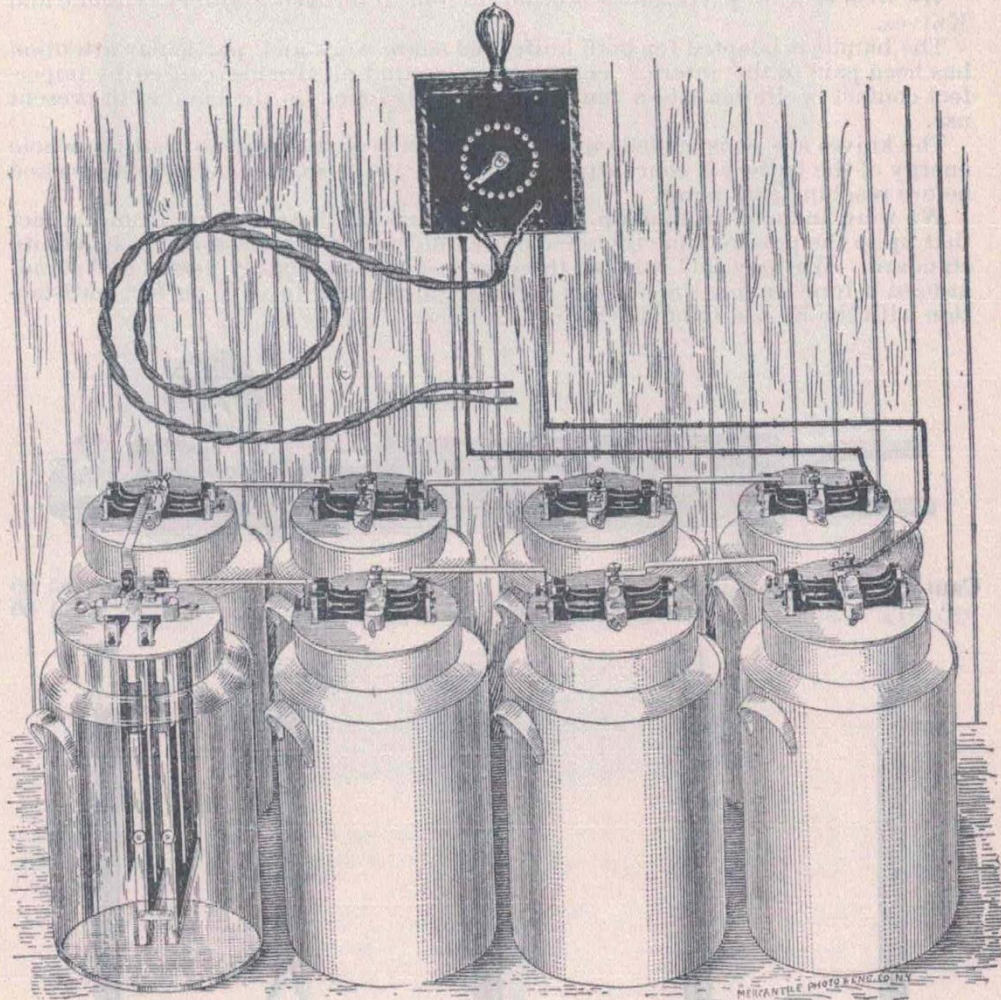

Same outfit as Cautery Battery "L," but with Type "M" Porcelain Cells instead of Type "L," which have twice the life of the latter... \$60 00

Prices of Renewal Parts of each Cell.

2 outside Zinc Plates, 21c. each	} (capacity, one charge) \$0 80
1 middle Zinc Plate, 38c.		
4 Copper Oxide Plates (capacity, 2 charges), 46c. each	 1 84
Can containing 4 sticks Caustic Potash (1 charge)	 52
Bottle Heavy Paraffine Oil sufficient for 1 charge	 08
Total	 \$3 24
The oxide plates in this cell will stand one renewal of zinc plates and solution before being exhausted.		
Price of M. cell complete including charge	 \$6 75
Stained and varnished lead lined oak box mounted on castors to hold 8 type M cells	 \$6 00

EDISON CAUTERY HANDLE AND KNIVES.

We wish to call particular attention to our improved Cautery Handle and Knives.

The handle is adapted for both knife and snare work and particular attention has been paid to the interior construction, so that all trouble caused by imperfect contact is eliminated—a fault so frequently found in the handles in present use.

The knives are constructed on strictly scientific principles, so that the whole energy of the battery is concentrated in the platinum tip, instead of being wasted before reaching that point.

We were induced to take up the manufacture of these knives from the fact that up to the present time there have been no cautery knives made to a definite standard. We may add that all these knives are thoroughly tested and standardized before leaving the factory and are guaranteed to give perfect satisfaction with the Edison-Lalande Cautery Battery.



Cautery Handle complete.....	\$5 00
“ “ Without attachment.....	4 00

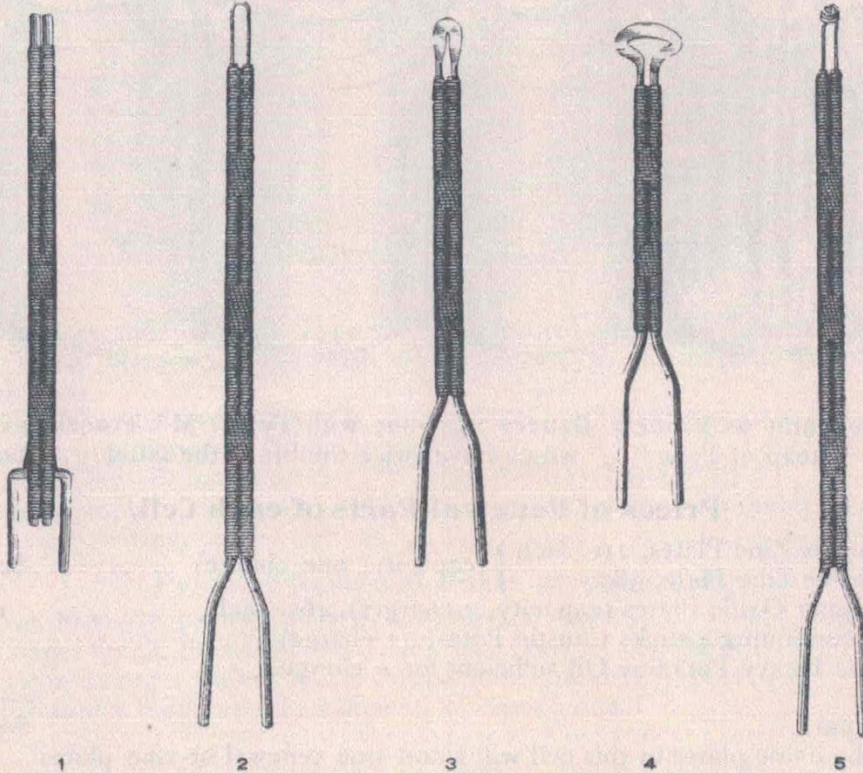

Snare Canula No. 1.....	\$1 50
Platinum Snares, 18 in. long.....	1 25
Cautery Knives, No. 2, \$1.50; No. 3, \$2.00; No. 4, \$2.00; No. 5, 1 50	
Special knives can be made to order.	

EDISON CAUTERY INSTRUMENT CASE.

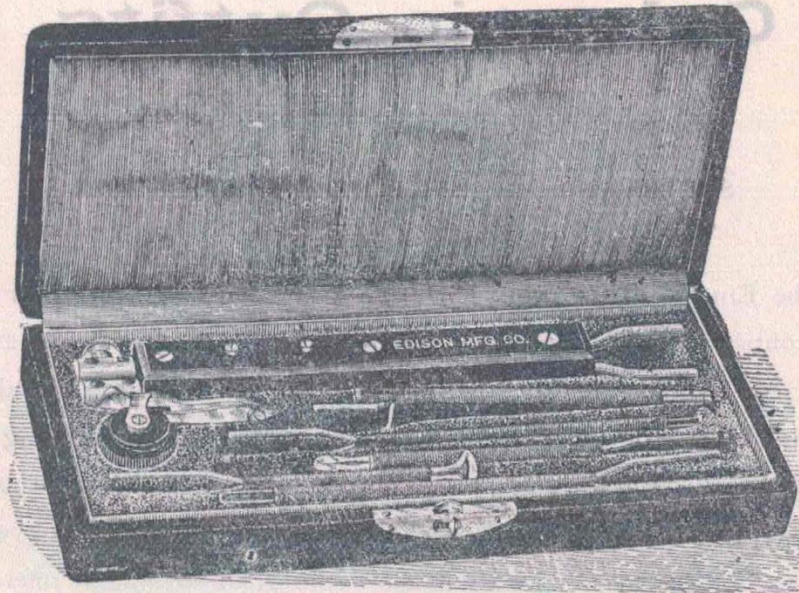

Morocco Leather Case containing one Edison Cautery Handle, with snare attachment, canula and platinum snare, also one each Nos. 2, 3, 4 and 5 Cautery knives.....**\$16.00**

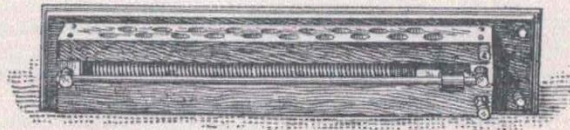

Sliding Cautery Rheostat on polished oak base..... **6.00**
 Sliding Miniature Lamp Rheostat, on polished oak base..... **7.00**

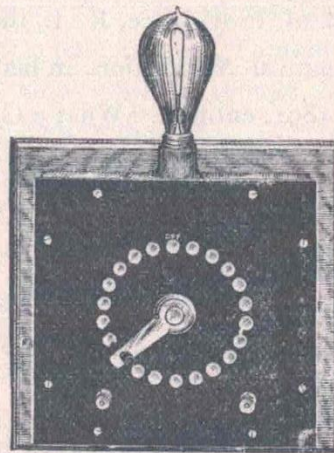

Circular Cautery Rheostat, with Hard Rubber top on polished oak base..... **10.00**
 Cautery Cords..... **4.00**
 Heavy Wire Cautery Leads, ten feet long, per pair..... **1.25**
 Leads over ten feet will cost per foot **.10**
 Miniature Incandescent Lamps, from one to six candle power, to run with Cautery Batteries F, L or M, each..... **1.00**

Galvanic Outfits.

SWITCHBOARD AND BATTERIES FOR OFFICE WORK.

The EDISON *Galvanic Batteries* and *Switchboard* for office work consist of 50 Edison-Lalande cells, Types "A" or "C," with switchboard, pole-changer, and Faradic coil, with interchangeable fast and slow vibrator. This is the most complete outfit for a physicians operating room and will furnish a perfectly even and constant current during the whole life of battery, during which time it needs absolutely no attention whatever.

The profession will readily recognize the great advantages offered by these batteries for apostoli work, as, although it is absolutely necessary to use a perfectly even current for this work, it has hitherto been impossible to obtain a battery that would deliver a steady current, and recourse has had to be made to an adjustable rheostat for regulation as the current in battery fell off. This is now rendered unnecessary, as the Edison-Lalande Battery will give absolutely the same current for hours or even days at a time if required.

Dr. W. F. Hutchison of Providence, R. I., the Vice-President of the American Electro-Therapeutical Association, in his paper read before that body on September 24th, 1891, entitled "What a General Practitioner can do with Electricity," says: "For office purposes, where maximum of life and minimum of trouble are requisites, I have not found anything equal to the New Edison Cell, marked Type "C" in his catalogue. It is neat, as cheap as any other, has a life of fifty ampere hours, which means a year's work for a general practitioner, may be repaired by any one, and has that most valuable of all qualities, it will stay, in other words, it will give the same voltage, about seven-tenths volt per cell, as long as any part of the elements remain. It does not commence work with one volt per cell and slide steadily down to nothing, as every variety of Leclanche cell does; one may always depend upon it.

Galvanic Switchboard.

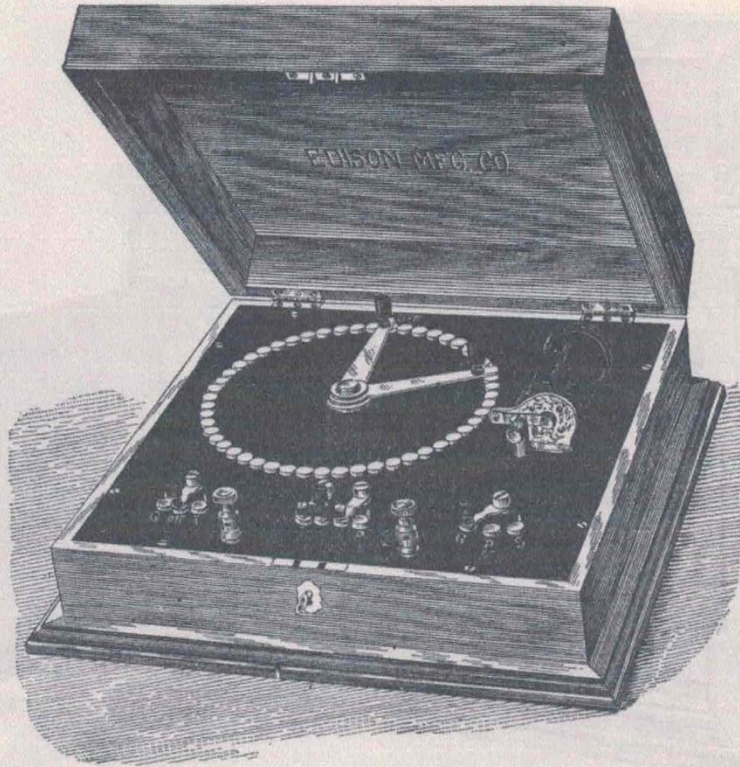

- Hard Rubber Switchboard, in black walnut case, containing 50 buttons, selector switch, pole changer, Faradic coil, with interchangeable fast and slow vibrator, sponge electrodes, battery cords and cable, as shown in the cut.....**\$30.00**
- The same with bevelled plate glass in top of case..... **32.00**
- Complete Outfit for office work, consisting of a Hard Rubber Switchboard, as above cut, and 50 Type "A" Cells (any number of which can be used on the induction coil), cords, sponge electrodes and cable..... **67.50**
- The same outfit as above, but with Type "C" Glass Cells, which will last over three times as long as Type "A"..... **87.50**
- Ditto, with Porcelain Cells..... **95.00**
- Unless specially ordered cables for the above outfits will be supplied ten feet long.
- Cables of extra length will be charged for at per foot..... **.22**

Galvanic Switchboard
EDISON GALVANIC CABINET FOR OFFICE WORK.

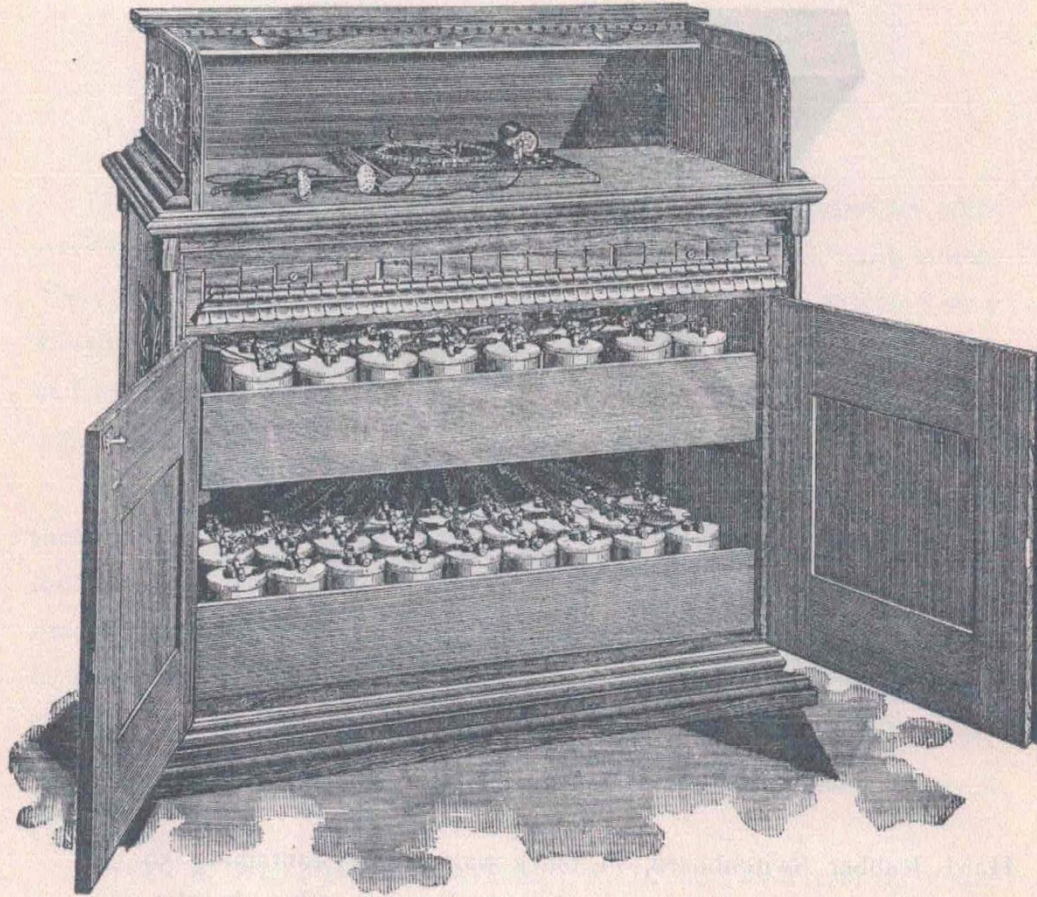

FLOOR SPACE 3 FT. 10 X 2 FT. 2.

This outfit consists of a handsomely carved quartered oak roll top cabinet, in the lower part of which are two sliding lead lined trays to hold the 50 type C Edison-Lalande cells, connected with the switchboard on top of cabinet. The switchboard is similar to the one on page 9. The cabinet has two drawers for electrodes etc., and is fitted with Yale locks. No expense has been spared to make this the handsomest and most efficient outfit in the market.

Price List.

Cabinet as above complete with cords, sponge electrodes and 50 type C cells with glass jars (see page 11) price.....\$137 50
 The same with porcelain jars (see page 12) price..... 145 00

Price of Renewal Parts for Complete Battery.

50 CELLS TYPE C.

50 Copper Oxide Plates.....	6 00
50 Zinc Plates.....	5 00
5 Cans Caustic Potash each containing 20 sticks.....	4 00
3 quarts Heavy Paraffine oil.....	60
Total.....	\$15 60

EDISON COMBINATION CAUTERY AND GALVANIC CABINET.

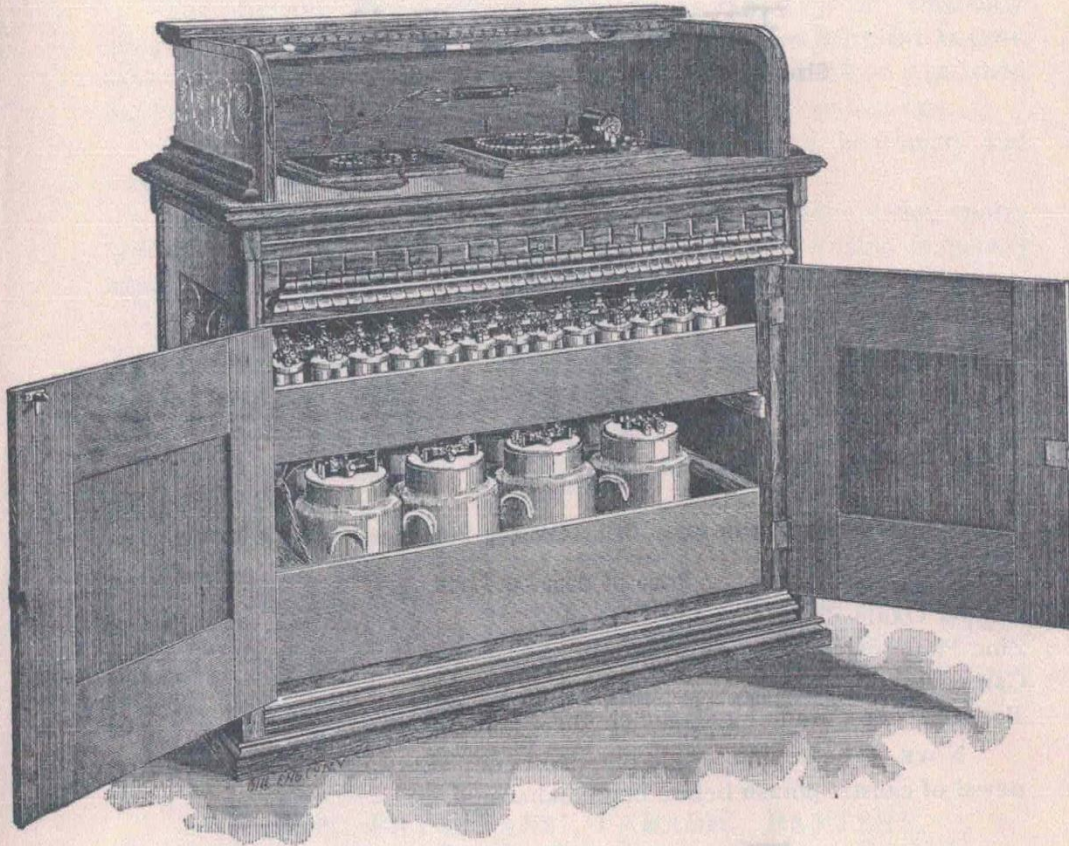

FLOOR SPACE 3 FT. 10 X 2 FT. 2 IN.

This cabinet is similar in design to the galvanic cabinet illustrated on the previous page. The eight Edison-Lalande cauterizing cells are contained in the lower tray and are connected to a circular rheostat mounted on the top alongside the switchboard which is connected with 50 Edison-Lalande cells for galvanic and faradic work contained in the upper tray.

Price List.

Cabinet complete with 8 type M cells for cauterizing work (see page 5) and 50 type A cells for galvanic work (see page 12) with rheostat, switchboard (see page 9) battery cords, cauterizing cords and sponge electrodes.....\$190 00
 The same only with 8 type L cells for cauterizing work (see page 4) and 50 type A cells for galvanic work (see page 12)..... 175 00

Price of Renewal Parts for Complete Batteries.

8 TYPE M CELLS.

32 copper oxide plates (capacity 2 charges).....	14 72
16 Outside Zinc " (" 1 ").....	3 36
8 Middle " " (" 1 ").....	3 04
4 Cans Caustic Potash each containing 8 sticks.....	3 84
Half Gallon Can Heavy Paraffine Oil.....	30

50 CELLS TYPE A.

50 Copper Oxide Plates (capacity 2 charges).....	4 00
50 Zinc " " (2 ").....	3 50
2 Cans Caustic Potash each containing 50 sticks.....	2 00
Half Gallon Can Heavy Paraffine Oil.....	30

EIGHT CAUTERY CELLS L.

32 Copper Oxide Plates (capacity 2 charges).....	8 00
24 Zinc " " (2 ").....	5 04
2 Cans Caustic Potash each containing 8 sticks.....	1 92
Half Gallon Can Heavy Paraffine oil.....	30

Cells for Galvanic Work.

Type "A" Cell.

Size, 2½ in. X 5 in. Capacity, 15 Ampere-Hours.

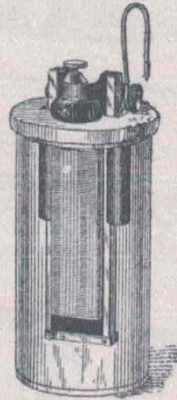

Price Complete with Glass Cell, including Potash and Oil, 75 Cents.

Price of Renewal Parts.

Copper Oxide Plate (capacity, 2 charges)	\$0 08
Zinc Plate (capacity, 2 charges).....	07
Can containing 2 sticks Caustic Potash (1 charge) ..	08
Bottle Heavy Paraffine Oil, sufficient for 1 charge.....	04

NOTE—The copper oxide plate and zinc in this cell will stand one renewal of caustic potash before being exhausted.

Type "C" Cell.

SIZE 3¼ IN. X 6 IN.

CAPACITY, 50 AMPERE-HOURS.

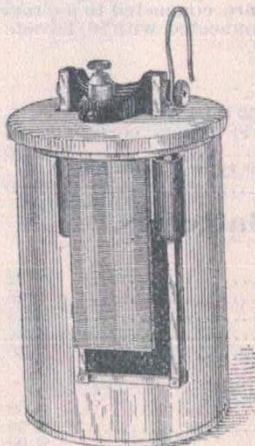

Price Complete, with Glass Cell	-	-	\$1.15
" " " Porcelain Cell	-	-	1.30

These Prices include Potash and Oil.

Price of Renewal Parts.

Copper Oxide Plate (capacity, 1 charge).....	\$0 12
Zinc Plate (capacity, 1 charge).....	10
Can containing 2 Sticks Caustic Potash (1 charge).....	12
Bottle Heavy Paraffine Oil, sufficient for 1 charge.....	05

We strongly recommend vetrified Porcelain Jars with Type "C" Cell as they are much stronger than glass, and are warranted not to crack from heat generated by dissolving of the potash.

Faradic Batteries.

The EDISON *Physicians' Faradic Battery* is eminently adapted for the use of the profession, and consists of two EDISON-LALANDE cells connected to a powerful medical induction coil mounted on a polished hard rubber base; the whole outfit enclosed in a polished walnut box.

The coil is so wound that the strength of current in the primary and secondary is perfectly progressive.

The vibrations obtained are of a very pleasing character, being entirely free from uneven pulsations, a cause of considerable trouble frequently experienced.

When battery is not in action it is unnecessary to remove the zincs from solution as in most other Faradic batteries, but simply to turn the switch as there is no waste on open circuit.

The current furnished by the cells is perfectly constant, so that battery can be used for hours without falling off in strength.

The cost of renewal of battery is very low and perfectly easy to accomplish.

The EDISON *Family Faradic Battery* fills a demand for a first class battery at a moderate price. In construction it is similar to the physicians' battery, only that the coil is mounted on a walnut base to match the box, instead of hard rubber, and the cells have porcelain covers.

In both these batteries the cells are perfectly airtight.

EDISON PHYSICIANS' FARADIC BATTERY.

Price Complete, in Polished Walnut Case, together with Sponge Electrodes.....\$15.00

The same with interchangeable fast and slow vibrators..... 16.00

Price of Renewal Parts For Both Cells.

2 Copper Oxide Plates..... \$0 16

2 Zinc Plates..... 16

Can containing 4 sticks Potash.. 16

2 oz. Bottle of Oil sufficient for 2 cells..... 05

Total..... .53

The Copper Oxide Plate and Zinc Plate will stand two charges (one renewal) of caustic potash solution before being exhausted.

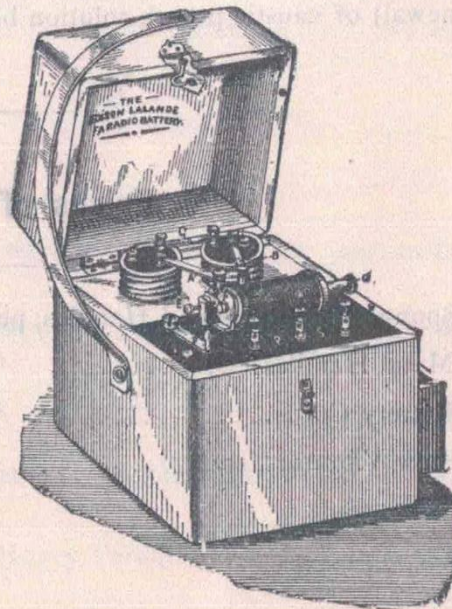

EDISON FAMILY FARADIC BATTERY.

Price complete, in Polished
Walnut Case, together
with Metal Electrodes..\$10.00

Price of Renewal Parts For Both Cells.

2 Copper Oxide Plates.....	\$0 16
2 Zinc Plates.....	16
Can containing 4 sticks Potash.....	16
2 oz. Bottle of Oil for 2 cells.	05
Total....	53

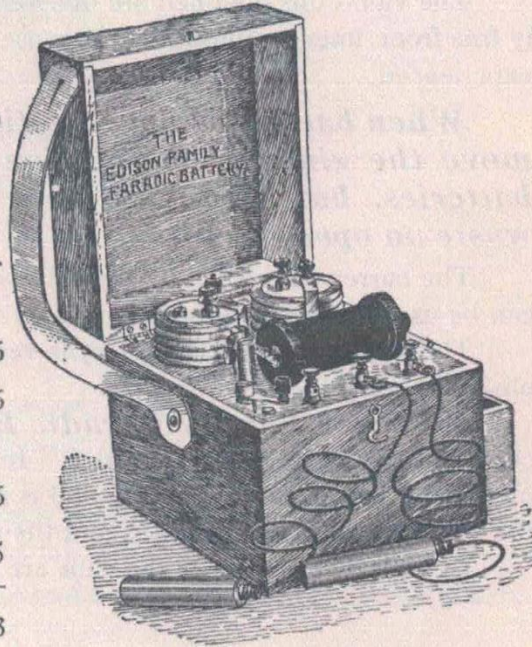

The copper Oxide Plate and Zinc will stand two charges (one renewal) of caustic potash solution before being exhausted.

Prices of Accessories.

Sponge Electrodes and Handles, per pair.....	\$1.00
Metal Handles.....	“ “ .50
Battery Cords.....	“ “ .50
Slow Vibrators, each.....	1.00

EDISON BATTERY FAN MOTOR.

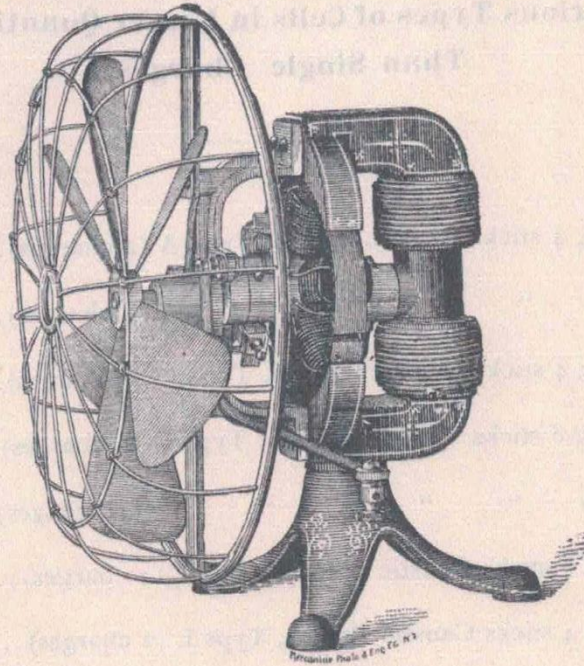

Price with fan and guard.....\$12 00
 Outfit including 4 Edison-Lalande cells, type K, in lead lined box,
 battery cords, motor, fan and guard, complete to run one hun-
 dred hours..... 25 00

Type K. Cell.

Size 5 x 11. Capacity, 300 Ampere-Hours.
 For small motor, analytical and laboratory
 work.
 Price complete with porcelain jar...\$2 85

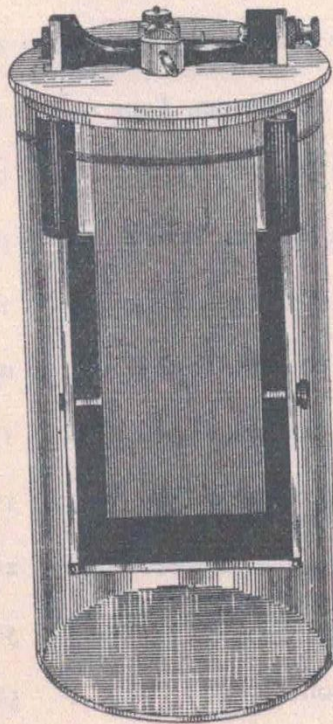

Price of Renewal Parts per cell.

2 Copper Oxide Plates, 25 cts. each.. .50
 2 Zinc " 21 " "42
 Can containing 2 sticks Caustic Potash .28
 Bottle Heavy Paraffine Oil..... .05

**Prices of Potash Sticks and Heavy Paraffine Oil for
Various Types of Cells in Larger Quantities
Than Single Charges.**

Can containing 4 sticks Caustic Potash, Type A (2 charges).....	\$0 14
“ “ 50 “ “ “ “ (25 charges).....	1 00
Can containing 4 sticks Caustic Potash, Type C (2 charges).....	22
Can containing 8 sticks Caustic Potash, Type C (4 charges).....	40
“ “ 20 “ “ “ “ (10 chages).....	80
Can containing 8 sticks Caustic Potash, Type F (4 charges).....	64
Can containing 4 sticks Caustic Potash, Type L (2 charges)....	52
Can containg 8 sticks Caustic Potash, Type L (4 charges).....	96
Can containing 8 sticks Caustic Potash, Type M (2 charges).....	96
4 oz. Bottle Heavy Paraffine Oil, sufficient for 4 charges, Type A....	05
8 oz. Bottle Heavy Paraffine Oil sufficient for 8 charges, Type A....	08
16 oz. Bottle Heavy Paraffine Oil, sufficient for 16 charges, Type A..	12
4 oz. Bottle Heavy Paraffine Oil, sufficient for 2 charges, Type C....	05
8 oz. Bottle Heavy Paraffine Oil, sufficient for 4 charges, Type C....	08
16 oz. Bottle Heavy Paraffine Oil, sufficient for 8 charges, Type C...	12
8 oz. Bottle Heavy Paraffine Oil, sufficient for 2 charges, Type F or L.	08
16 oz. Bottle Heavy Paraffine Oil, sufficient for 4 charges, Type F or L.	12
16 oz. Bottle Heavy Paraffine Oil, sufficient for 2 charges, Type M..	12
Heavy Paraffine Oil, 1 quart.....	20
Heavy Paraffine Oil, half gallon.....	30
Heavy Paraffine Oil, 2 or 3 gallon cans, per gallon.....	50

—22—

THE "SMITH & SHAW"
CLOSED CELL
POCKET BATTERY.

In the application of electricity to the cure of diseases and relief of pain, a most important point to be considered is the selection of a proper apparatus, and at the same time one that is portable and easily handled.

While there are various styles and makes of Batteries in the market, many of which are excellent instruments in their way, still the main trouble and impediment to their ever coming into general favor, lies in the fact that they are made so complicated, and the price so high, that only a comparative few could afford to purchase or ever learn how to properly handle them; furthermore, the construction, size and constant danger of spilling the Battery fluids (acids), is such that the claim of any such Battery being a portable instrument is unfounded.

The country is flooded with electro-medical machines of great pretensions, but in too many instances of doubtful utility.

A demand has therefore sprung up for a Battery, simple and compact in construction, **effective** in action, **durable**, **cheap** in price, and above all, **portable** in the true sense of the word, that is, a Battery that can be carried in the pocket or valise, charged and ready for immediate use, and the cells so constructed that they are absolutely air and acid-tight.

In view of all these facts we have made it a study to so construct a Battery as to embody all the above points, and after long and expensive experiments our efforts in this direction have finally been crowned with signal success, and we take pleasure in announcing that we have succeeded in producing a Battery calculated to meet the wants of the

—23—

physician and layman alike, and with the greatest confidence, we submit to public inspection, criticism and judgment,

THE "SMITH & SHAW"
CLOSED CELL POCKET BATTERY.

combining improvements of so radical a nature as to make it the Pocket Battery of the age.

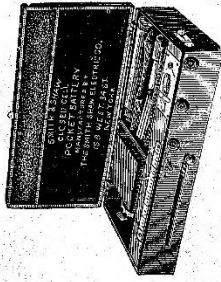

BATTERY No. 1 is but 6 inches long, 3½ inches wide, and 1¼ inches high. Outside measurement.

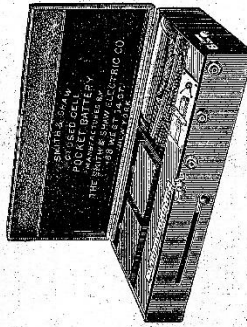

BATTERY No. 2, 7½ inches long, 3½ inches wide, and 3¼ inches high. Outside measurement.

1st.—These sizes will admit of their being comfortably carried in the pocket.

2d.—They weigh from $\frac{3}{4}$ to 1 $\frac{1}{4}$ pounds respectively. The boxes are made of well-seasoned polished Mahogany, and their neat construction and elegant workmanship make them an ornament for any office or household.

3d.—The 2-Cell Battery is capable of producing a current of great power, and is specially adapted to Physicians' use. By a simple arrangement (see Directions p. 29) one cell can be used alone, thus saving cost of running and giving as gentle a current as any one may desire.

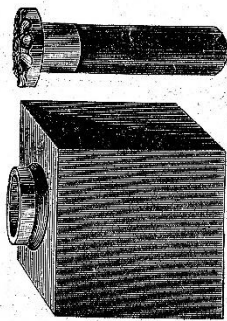

4th.—The Cells are of hard rubber with carbon chamber, charged with a solution of *Bi-sulphate Mercury*, into which a zinc rod is immersed. The zinc rod has a rubber head fitting tightly into the neck of the cell, making the whole absolutely air and acid tight, thus enabling the operator to carry the Battery in any position charged and ready for immediate use. In addition to the above special advantages, we call attention to their

A. CURRENT CAPACITY.

They have a current so mild that it cannot be felt excepting by the most sensitive, and yet be gradually increased to one so strong as to fully meet the requirement of any medical demand.

B. CURRENT QUALITY.

The disagreeable jerk, or electric "thump," so characteristic of many Batteries, is not found in these, but a current

that is nowhere excelled for its fineness, smoothness and agreeableness.

C. COST OF RUNNING.

As the cell will give 8 to 12 hours work, and can be used from day to day, until that much electric energy is consumed upon the same charge of *Bi-sulphate Mercury* used to get one hour's work out of a once popular Electric Machine, there is no question as to the claim of economical working.

D. CONVENIENT MANIPULATION.

The conducting-cords are attached on the outside of the box, the Graduator is outside, most handily placed, and cannot fall out, the "Cut-off," for "making" and "breaking" circuit is also outside.

E. MATERIALS OF CONSTRUCTION.

As stated before the boxes are of highly polished mahogany. The induction coil is made of best copper wire, carefully wound by skillful hands and properly proportioned to produce the best effects. The excellence of the coil in this Battery is a prominent feature, being so arranged as to get the desired ranges in the qualities of currents in a very small space. The Rheotome is made on an improved plan, and not liable to get out of order, by a small thumb-screw attached to same, the operator has perfect means for controlling the length and regularity of vibration.

All metallic parts are finely nickel-plated, and with each Battery we supply one pair conducting cords, one pair handles, one fine wire brush electrode, zinc glass drip-cups, vial of bi-sulphate of mercury and scoop. With the 2-cell Battery we include an olive pointed electrode for internal parts.

PRICE: { No. 1.—One Cell Battery, (complete) \$ 7 50
 { No. 2.—Two " " 10 00

Sent by mail or express.



Fig. 1.—FINE WIRE BRUSH.....\$1 00
Is used for the skin and to restore sensation when lost. This electrode is furnished with each 1 and 2-cell battery, (without extra charge).

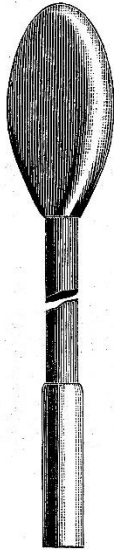

Fig. 2.—RECTAL ELECTRODE.
Also used for Vagina. Insulated, 10 1/4 inches long. Can be screwed on to the regular wooden handles accompanying battery.....\$1 50

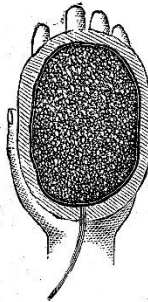

Fig. 3.—SPONGED COVERED ELECTRODE
Insulated with soft rubber back for general application with the hand. Has permanent conducting cord attached\$1 50

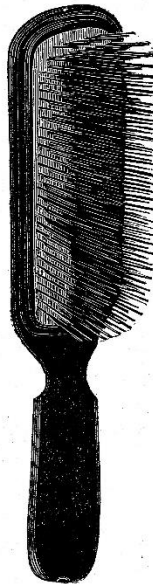

Fig. 4.—HAIR BRUSH ELECTRODE.....\$2 00
This may be used not alone for the hair, but for the entire surface of the body, and is a most excellent method of strengthening the aged and those who can take little exercise.

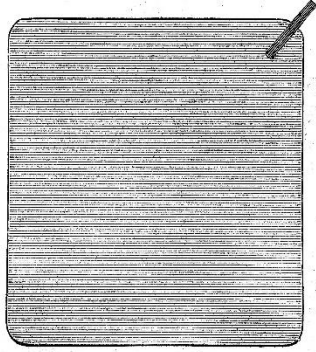

Fig. 5.—METALLIC FOOT PLATE, polished, 10 1/2 x 9.....\$0 75
" " " " nickel plated..... 1 00
We also make a Folding Foot Plate, nickel plated..... 1 50

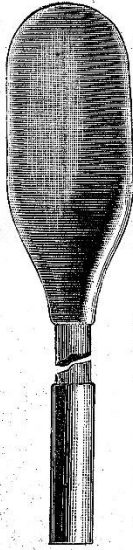

Fig. 6.—TONGUE PLATE, insulated, 5-inches long.....\$1 50
Can be screwed on to the regular wooden handles accompanying the Battery.

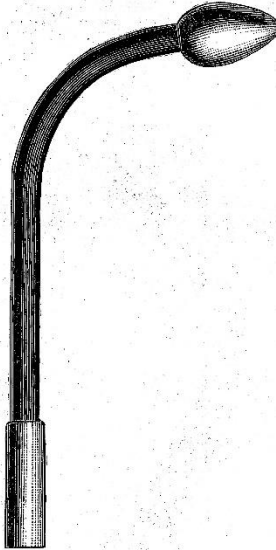

Fig. 7.—OLIVE-POINTED ELECTRODE, insulated, for internal parts.....\$1 00
This electrode is furnished with each 2-cell battery, (without extra charge).

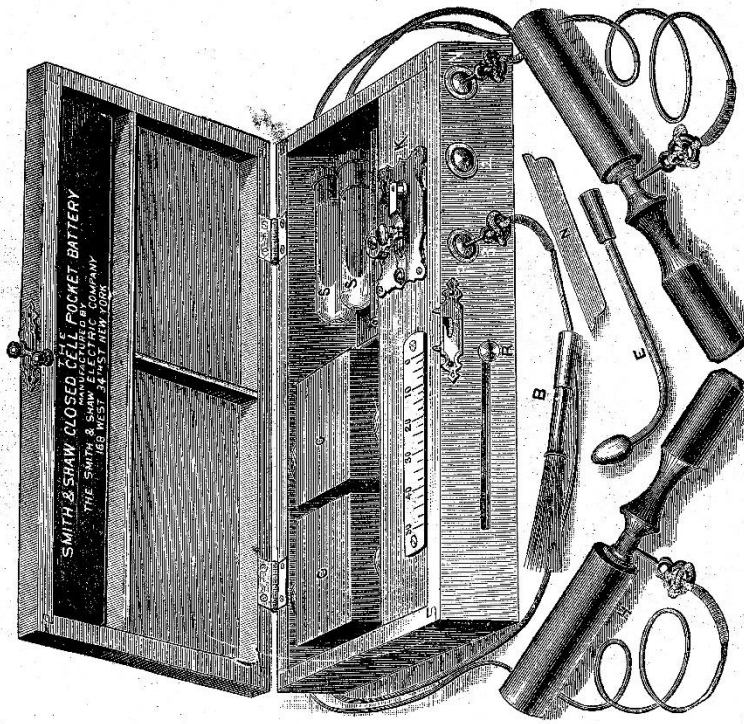

Illustration of our Battery and the Appurtenances
Furnished Therewith.

DIRECTIONS.

TO CHARGE THE ONE-CELL BATTERY.

Take out the cell, fill it half-full of water, put in $1\frac{1}{2}$ scoop-fulls of Bi-sulphate Mercury, shake well, insert zinc rod, and press the rubber-head firmly down in neck of cell, then replace cell between the springs with stopper *next left hand end of box.*

TO CHARGE THE TWO-CELL BATTERY.

Take out the cells, fill each one half-full of water, put in each $1\frac{1}{2}$ scoop-fulls Bi-sulphate Mercury, shake well, insert zinc rods, and press the rubber heads firmly down in neck of cells, then replace cells between the springs with stoppers *next back of box.*

TO CONNECT CONDUCTING CORDS.

For primary or mild current.—Insert the metal tips into the holes (poles) on the outside of box marked 1 and 2.

For secondary or intermediate current.—Insert the metal tips into holes (Poles) 2 and 3.

For combined or strong current.—Insert the metal tips into holes (Poles) 1 and 2.

TO START THE CURRENT.

Move knob on right hand end of box towards you.

TO INCREASE THE CURRENT.

Move Graduator Knob (K) in slot in Box-front, from right to left, reversing the movement when decrease is required.

TO USE ONE CELL ONLY (in the Two-Cell Battery).

Remove either cell, and press the metallic strip (N) accompanying the Battery, down between the two springs in empty cell chamber.

DURATION OF THE CHARGE.

The charge will give from 8 to 12 hours electric work, and can be used from day to day until that much electric energy is consumed. If used half an hour a day, will run 12 to 16 days without re-charging, of course if used for a shorter time each day, the duration of charge will be longer accordingly.

When not in use, the rubber stopper should be inserted in cell, and the zinc rod put in glass drip-cup.

TO RE-CHARGE THE BATTERY.

Rinse the cell until the water is clear, then charge as at first. The Battery can be carried in any position, with the cells charged.

MARVEL HIGH FREQUENCY GENERATORS



MARVEL No. A-1 Price \$12.50

High grade, well built, one-piece instrument. Equipped with surface electrode.



SUPER MARVEL No. 3 Price \$16.50

Finely built, one-piece instrument, packed in lined carrying case. Equipped with surface, comb and throat electrode.

The Marvel High Frequency Generator is not a cure all. It has a definite place in the medical field.

Many human ailments are traceable to imperfect circulation. The stimulating effect of the generator aids in the promotion of circulation and that is its primary function.

For all specific ailments, your family physician should be consulted regarding the use of the generator, as he naturally knows your condition and will recommend treatment if it is indicated in your case.

MARVEL ELECTRODES

(Made to fit all standard instruments with 7/16" ID electrode socket holder)

- 

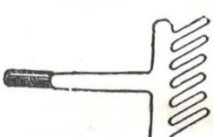
S-1 Surface \$1.20
- 

S-3 Comb \$1.80
- 

S-5 External throat \$1.20

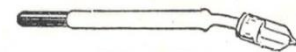
- 

S-20 Fulguration \$2.40



No. S-6—Metal electrode or Saturator, used in giving indirect treatments \$1.50

- 

S-4 Spinal \$2.40

—ELECTRODES CANNOT BE EXCHANGED AND ARE NOT GUARANTEED—

ADDITIONAL LIST OF ELECTRODES ON OTHER SIDE

EASTERN LABORATORIES INC

216-226 EAST 45TH STREET

NEW YORK (17), N. Y.

MARVEL ELECTRODES



No. S-56—Insulated Ear Electrode\$2.40



No. S-18—Single eye electrode.....\$1.20

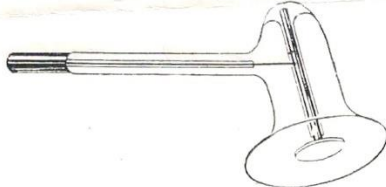

No. S-2—Large condenser electrode, equipped with lead-in device which carries current right to surface of electrode. Delivers strong current for use in cases of Rheumatism, Lumbago, etc.\$3.60

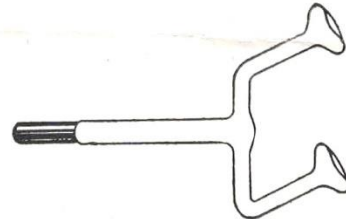

No. S-39—Double Eye electrode..\$2.40

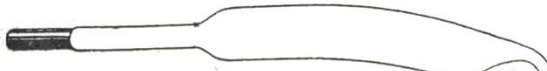

No. S-13—Plain Vaginal electrode.....\$1.20



No. S-14—Plain rectal electrode, small dia. (5/8").....\$1.20



No. S-30—Insulated vaginal electrode.....\$2.40



No. S-35—Plain rectal electrode, medium dia. (3/4").....\$1.20



No. S-31—Insulated vaginal electrode for the generation of ozone within the vagina.....\$3.60

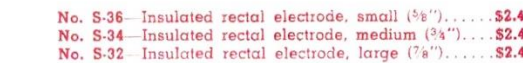

No. S-33—Plain rectal electrode, large dia. (7/8").....\$1.20

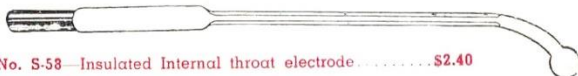

No. S-58—Insulated Internal throat electrode.....\$2.40



No. S-36—Insulated rectal electrode, small (5/8").....\$2.40

No. S-34—Insulated rectal electrode, medium (3/4").....\$2.40

No. S-32—Insulated rectal electrode, large (7/8").....\$2.40

No. S-21—Plain vacuum electrode, good for many uses as for instance for treatment of the vocal cords, over ovaries, as handle for indirect applications.....\$1.80



No. S-10—Plain internal throat electrode.....\$1.20

No. S-41—Dental electrode for gum treatment, right side of jaw.....\$2.40

No. S-50—Insulated urethral electrode\$2.40

No. S-9—Insulated prostatic electrode\$2.40

No. S-44—Dental electrode for gum treatment\$2.40

No. S-19—Corn electrode\$1.20

No. S-46—Insulated electrode, covers small areas\$2.40

No. S-49A—Insulated dental abscess electrode\$2.40

No. S-49—Plain dental abscess electrode\$1.20

No. S-52—Dental electrode, hollow bulb\$2.40

No. S-43—Dental electrode for gum treatment, inside of jaw.....\$2.40

No. S-51—Plain urethral electrode.....\$1.20

No. S-7—Insulated spatulum or tongue electrode.....\$2.40

No. S-57—Dental electrode, ball shaped bulb\$2.40

No. S-40—Dental electrode for gum treatment\$2.40

No. S-47—Dental electrode, straight bulb\$2.40

No. S-53—Dental electrode for front gum treatment.....\$2.40

No. S-8—Plain nasal electrode.....\$1.20

No. S-42—Dental electrode for gum treatment, left side of jaw.....\$2.40

No. S-59—Dental fulguration electrode\$2.40

No. S-12—Eyelid electrode\$1.50

No. S-54—Dental kataphoric (cocaine) electrode\$2.40

No. S-48—Dental electrode for spotting certain areas.....\$2.40

No. S-45—Dental electrode for inside of jaw\$2.40

No. S-11—Insulated nasal electrode\$2.40

—ELECTRODES CANNOT BE EXCHANGED AND ARE NOT GUARANTEED—

The Marvel Violet Ray

Book of Instructions

EASTERN LABORATORIES, Inc.

227-229 East 38th Street

New York, N. Y.



How to Treat With Violet Rays

Including
Alphabetical List of Ailments for which
Violet Rays are adaptable

ONE CAUSE FOR ALL DISEASE AND WEAKNESS

*A*ll human ailments, with the exception of highly infectious and contagious diseases, are traceable to one cause: Imperfect circulation and impoverished blood.

During our youth, when we take plenty of exercise, enjoy sound sleep, our blood is rich and we are insured of a copious supply to every part of our body.

Gradually, as we grow older, we pursue a more sedate mode of living and our circulation slows down at the same time. The flow of blood through our veins is slower and our whole body suffers.

When our body is in this condition, germs find fertile field to lodge and multiply.

For this reason, weak and run-down persons become easy prey to almost any disease to which they are exposed.

HOW TO REMEDY THIS CONDITION

It is reasonable to assume that by increasing the flow of blood through the body, the reverse of this process will be true and the congestion and disorder can be relieved.

A systematic course in physical culture will, in time, renovate the body completely. Few of us are able to devote necessary time to such course. By means of Violet Ray treatment, every functional activity of the body can be speeded up and the blood made to run through the veins with renewed vigor.

CONCENTRATION

An important feature of this treatment is that it can be concentrated to any particular organ that requires special treatment. It brings a vigorous surge of rich, warm blood to any part, thereby washing away the silt of disease, strengthening and nourishing the tissues, and giving vigor and vitality to any part treated.

WHAT THE VIOLET RAY IS

The Violet Ray High Frequency Current, or as it is more commonly called, the "Violet Ray," is a new phase of electricity. It is applied to any part of the human body without pain, muscular contraction or disagreeable sensation of any kind. The electrical oscillations representing the High Frequency Current follow each other with such tremendous rapidity that they out-speed our nervous sensibility; we do not become conscious of their presence; in other words our nerves are insensitive to the electrical oscillations of the Violet Ray. The oscillations are so rapid that they exceed many thousand repetitions per second. The Violet Rays are pleasing, and though most stimulating and highly invigorating to the entire system, nerves and muscles, cannot record the presence of their great power.

WHAT VIOLET RAYS ACCOMPLISH

Violet Rays or High Frequency Currents benefit all living matter. Through the glass vacuum applicator light, heat, electric energy and ozone are created. These forces are uniformly potent in relieving and eliminating human ailments. Violet Rays present a remedy upon which we can rely. They are positive and certain in action. They will reach where medicine does not, and often cannot—yet they cause no pain, no disagreeable sensation or discomfort. They furnish a soothing relief. They destroy germs and have a strong power over infection.

A Violet Ray treatment is the surest method of relieving pain. Applied to that part of the body where the pain is severest, the rays and High Frequency electrical discharge penetrate every cell, tissue and organ and tranquilize and soothe. They build up the forces of nutrition and general health. Violet Rays will stimulate and strengthen the vital organs, develop the body and steady the nerves, spraying thousands of volts of High-Frequency electricity into any weak, sluggish or painful organ or muscle, purifying and causing the flow of warm, rich blood to surge through the treated part, at the same time being painless and pleasant. Violet Rays have only to be tried to be appreciated.

CELLULAR MESSAGE

Every vibration of the violet ray causes the cells of the body to vibrate. This vibration gives the effect of a **massage**, and as its frequency is so high that it is insensible to us, its effect is rapid and powerful.

It imparts new life to each individual cell and enables it to more readily absorb the nutriment from the blood stream, thereby building new tissue. In short, it tends to revive and invigorate every bodily tissue by rejuvenating each individual cell of which it is composed.

SUMMARY EFFECT OF VIOLET RAY TREATMENT

When daily treatments are given with Violet Rays the following effects are observed:

Return of Sleep.

Increase of strength and vital energy.

Increase in cheerfulness and power for work.

Improvement in appetite, digestion, etc.

Increase of blood supply to the point of application.

General increase of local nutrition and progressive improvement in the general functions.

Increase of secretions.

Soothing effect on the nervous system.

Increase of oxygen in the blood. (Ozone being driven directly through the skin into the tissues, accomplishing "ozonization" of the blood.)

WHY YOU SHOULD USE VIOLET RAYS

Violet Rays should be used by everyone experiencing sickness or ailment of any kind. The healing properties of Violet Rays are manifold, and they accomplish what drugs and medicine never can. The regular introduction of a vitalizing shower of diffused electricity into your system is exactly what is needed to make it function properly and efficiently. To be healthy, use violet rays, to keep healthy, use violet rays.

There are three distinctly different ways of applying violet rays.

First: Soothing Effect.

This soothing, or sedative effect is administered by means of the glass applicator. To secure this effect the applicator is applied directly to the bare skin. You can calm painful sensation sensation by sedative treatment; these treatments are of great benefit to all nervous ailment. Nervous troubles are quickly and most beneficially influenced by the sedative currents. A general electrification treatment refreshes the entire nervous system.

Second: Stimulating Tonic and Invigoration.

Stimulation and invigoration is produced whenever an electrode is somewhat lifted during its application or used through cloth or clothing.

This stimulation is caused by the many small sparks called the High Frequency Spray. They bombard the area which they cover, causing a tingling but pleasant sensation. They have a beneficial heating effect, too. Besides they generate ozone. Particles of this ozone are driven right into the tissues, causing ozonization of the blood. Sparks are also germ-killing and have a great power over infection.

Stimulating treatments are best produced by application through the clothing or through a towel which has been put over the part to be treated. As the length of the stimulating spray depends on the thickness of the interposed dry resistance, that is the clothing or towel, any desired effect is obtainable. Anything from a handkerchief to a doubled Turkish towel can be used for this purpose. The use of any kind of cloth insures a uniformity in spark length which cannot be obtained in any other way. Powdering the skin with talcum powder often suffices to create the desired dry resistance. This will, at the same time, allow an easy sliding of the applicator. A slight perspiration results from the treatment—this is natural. If the application of talcum powder is not desirable, use of lubricant is recommended.

Stimulating treatments through clothing find a profound use in rheumatism, lumbago, partial paralysis, etc. Slight stimulation is also sometimes desired in skin troubles where the blood circulation is impaired. A single layer of a handkerchief presents enough resistance in such a case. Chronic rheumatic troubles, however, may require the use of several layers or a Turkish towel.

Long sparks from the applicator will cause a counter irritation. Counter irritation relieves wonderfully quickly pains of many sorts.

It is often the very welcome means to kill the pain of a toothache. You will appreciate this pain-relieving quality of the Violet Ray also in sprains, strains, bruises, etc. Counter irritating applications are better, swifter, and more effective than plasters and liniments. In fact, they replace them entirely. Stimulating treatments are long lasting in their effects. They are not like drugs or a glass of wine because they are not followed by a reaction. They do not create any habits.

Third: Internal Antiseptic.

The effect of inhaling ozone is much the same as that of inhaling copious quantities of pure air. It purifies and enriches the blood, invigorates the body, and causes pure oxygen to be taken up in large quantities in the blood stream.

Ozone inhalation is of particular benefit in the treatment of respiratory disorders. Taken into the lungs, it immediately attacks the disease cells and causes them to be oxidized and thrown off with the exhaled air. This treatment has been found to be of great benefit in cases of bronchitis, colds on the lungs, tuberculosis and similar troubles.

PAIN RELIEVING

Rheumatism

The blood deposits poisons when the circulation becomes sluggish, usually at the joints and we feel a slight pain. Continued deposits cause the joints to swell and inflammation to set in. This is called articular rheumatism. The same condition causes pain in the muscles and we have muscular rheumatism.

Violet Rays restore circulation and drive oxygen into the blood, thereby bringing back to a normal condition the afflicted part.

The Condensor Electrode is found most beneficial and should be taken twice daily with a medium strength current. The very first treatment brings a warm, glowing tinge to the skin and relief is apparent.

Neuritis

This may be treated in a similar manner as rheumatism, only with a milder current.

Lumbago

This is treated like rheumatism, preferably through the clothing, and with a strong current and with the condensor electrode, twice a day.

Headaches—Insomnia—Brain Fog

When the blood collects in pools throughout the body, it becomes stagnant. One of the most troublesome of these is the cavity in the skull where it directly affects the brain. This causes headaches, brain fog and insomnia. Everyone knows that prolonged mental effort will bring about a congestion in the brain that dulls our power of thought. When this is demanded over a long period of time, circulation is impaired, the nerves irritated and the familiar, dull headache, results. The general treatment is to use the surface electrode and apply it to the different parts of the head, thereby relieving the congestion.

Hair—Scalp—Skin

The hair roots are fed, just as every other part of the body is, through the blood. For treatment of the scalp we have a special comb applicator which pulls easily through the hair and conforms to the shape of the head. Millions of tiny electric sparks carry pure ozone to the small capillaries through which the blood flows in the scalp. These tiny capillaries are gently massaged, and nourishment is brought to the roots of the hair. The very first treatment brings a long, glowing, healthy feeling to the scalp, and with few successive treatments, itching will stop, hair will cease falling, and dandruff disappear. In many cases, gray hair will even be restored to its natural color. By stimulating the scalp apparently dead hair will quickly take on a natural glossy and healthy appearance.

The Violet Ray applied to the face, brings fresh, rich oxygen-laden blood, which cleanses the pores, dissolves poisons and other waste matter and assists nature to produce a natural, glowing, healthy condition or complexion. One short treatment every evening and every morning will work wonders on the complexion.

Run-Down Condition

General weakness, tiredness, loss of weight, lack of appetite, usually indicate anemia or impoverished blood and poor circulation. Violet Ray stands alone as the most potent treatment known to science in giving quick relief to such disorders.

This treatment is taken with the general body applicator over the entire body for five minute, twice daily, using a medium current. The metal applicator is also very beneficial and should be held firmly in the hands for ten minutes, twice daily, with a strong current which massages the body with a stimulating cellular massage. Ozone inhalations give very beneficial results.

Dyspepsia, Constipation and Digestive Disorders

This treatment consists in getting the blood into circulation so that it will find its way to the lungs to be properly purified. Then the digestive organs must be stimulated to function properly, so they will rid themselves of the accumulation of bodily waste. Its great advantage over medical treatment is that it can be applied directly to the seat of trouble.

For the relief of indigestion and constipation, the current should be first applied to the abdomen. The applicator should be held in loose contact with the skin, so that a mildly stimulating effect is obtained. This, in turn, will speed up circulation, stimulate the muscles of the abdominal wall and relieve the congested organs. Treatment of the spinal nerve centers should follow the above treatment.

STRENGTHENING THE REPRODUCTIVE SYSTEM

The various weaknesses that afflict these organs in both men and women spring from the same general causes as most other bodily weaknesses, and must be treated accordingly.

Correcting Female Complaints

It is true that the sexual system, particularly in women, is very delicately adjusted, and, consequently, any disorder affecting other parts of the body may have an influence on this system. Women suffering from anæmia, obesity, digestive disturbances and nervous disorders will, in nine cases out of ten, suffer from female troubles also. Because of this, they usually resort to treatment with some nostrum that acts directly on the organs instead of getting at the fundamental cause of the trouble.

In women, disorders of this kind may be classified into three groups: The first group includes those caused by weakness of the parts or of the supporting ligaments and tissues. The second group includes nervous complaints and the third those resulting from internal infections. Into the first class may be placed all displacements and similar troubles that are so common and distressing. The second, or nervous disorders, may be regarded as functional disorders that contribute to the development of the first

group. The third includes inflammations of all kinds in the pelvic region and manifest themselves through the several organs. Usually the symptoms indicate a complication of disorders falling into at least two of these classes.

Violet Ray treatment gives the most gratifying results in correcting disorders of this kind, for the reason that by proper application and treatment, the effects are both constitutional and local, which insures rapid improvement.

The third class of troubles mentioned—those caused by internal infections—are usually characterized by inflammation, pain and frequently by unnatural discharges. The treatment described in the preceding paragraph should be used, and in addition internal treatment with one of the vaginal electrodes, preferably the insulating electrode. This internal application acts not only as a local antiseptic, but relieves inflammations as well. Applicators for administering internal treatment will be found in the back of this booklet. The duration of this should not exceed five or six minutes.

TREATMENT FOR MEN

With men, disorders of the reproductive organs seldom cause the physical distress as with women, but their influence on the mental condition of the man is frequently even more severe. Men become afflicted with these troubles largely through the same causes as women—lack of exercise, faulty nutrition, nervous conditions, etc. These are all too frequently aggravated by excessive use of tobacco, alcohol and sexual indiscretions.

The same general tonic treatment prescribed for women should be taken by men also. In addition to this, great benefit will be derived from daily treatment of the external organs lasting for from five to seven minutes. This should be given with a medium current, keeping the applicator in loose contact with the skin so that a stimulating tonic effect is obtained.

PROSTATIC TROUBLE

Prostatic trouble becomes apparent in nearly all men after they reach the age of thirty-five or forty. The prostate gland is a small gland completely surrounding the urethra at the mouth of the bladder. Poor circulation, faulty nutrition, etc., cause this gland to become inflamed and swollen, and pain and agony results.

For permanent, lasting results, no other treatment will give the practically certain relief that comes from the use of Violet Rays. Prominent physicians report the most beneficial results in nine out of ten cases.

Treatment should be taken with either our special prostatic or insulated rectal applicators. By means of this, heat is brought in almost direct contact with the gland inside the body and relief is experienced at once. The circulation is improved, nutriment and oxygen are brought directly to the gland and the inflammation and pain disappears as if by magic.

External treatment should be taken over the entire lower spine. This stimulates and builds up the network of nerves running to and around the gland. A mild current should be used for about five minutes daily.

IMPORTANT

ALWAYS insert applicator into the handle with a straight push and remove with a straight pull.
NEVER TWIST.

ALWAYS turn off switch at light socket when through using. The adjustment knob on the instrument is to regulate the strength of current —not to use as a switch.

NEVER use the generator when in a bathtub or when connection is made from the body to the ground, by radiators, water pipes, lighting fixtures, etc.

NEVER use generator on the hair when using at the same time a hair tonic containing a large percentage of alcohol.

NEVER oil the generator.

NEVER attempt to repair the generators. Should it get out of order notify us. We will not be responsible for instruments that have been taken apart by the user or by electrical repairmen other than our own.

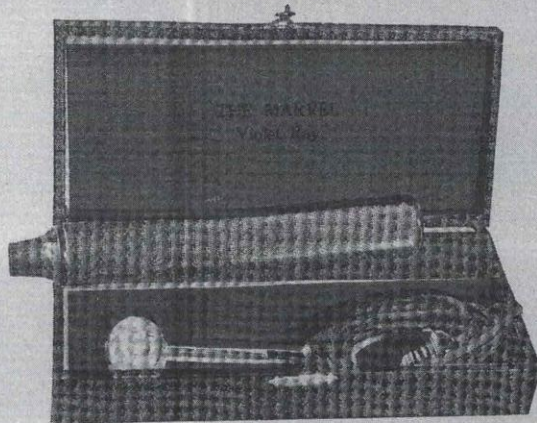

Marvel No. A 1

The Marvel is a high-grade, low-priced, well-built, one-piece instrument intended for private use and is equipped with surface electrode. Space is provided in the case for other electrodes if the customer wishes to buy them.

The instrument is wound with our specially prepared impregnated wire, which makes it unnecessary to bake the secondary coil in wax. It is encased in our "grip-tight" indestructible handle and is equipped with seven feet of high-grade cord and separable plug.

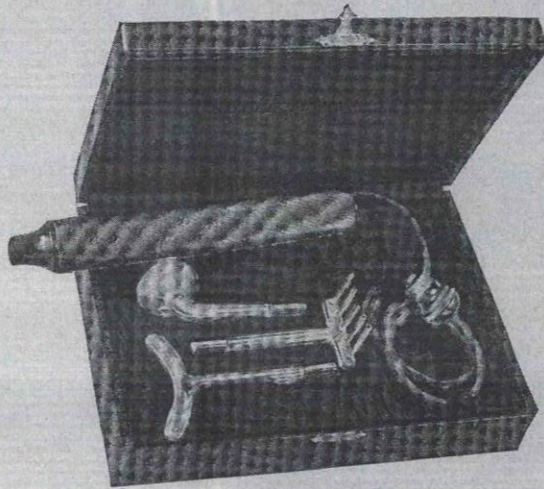

Super Marvel No. 3

The SUPER MARVEL represents the greatest value ever offered in a violet ray high-frequency generator. The instrument is finely built throughout, is exceedingly well insulated and the secondary coil is wound with our specially prepared impregnated wire, which eliminates the possibility of wax running and lowering of efficiency which occurs in instruments where it is necessary to bake the secondary coil in wax.

The machine is encased in our "grip-tight" indestructible handle, equipped with seven feet of cord and separable plug. It is smaller in diameter than any other high-grade one-piece machine on the market and being perfectly balanced, is very easy to hold.

The violet ray discharge is powerful and highly diffused, without any disagreeable kick. The machine is packed in a beautiful silk lined carrying case and is equipped with three electrodes, the surface, comb and throat.

PREPARATION FOR TREATMENT

Surface treatments can be given in direct contact with the skin, and also through the clothing. As any clothing represents an interposed dry resistance, a treatment through the same would cause small sparks. It depends entirely on the desired effect, which way to treat. The instructions given in this booklet refer to the proper technique. If no sparks are desired any clothing covering the part to be treated must be removed.

Metallic objects as hairpins, corset steels, chains, should be taken off if they cannot be avoided in the treatment.

FOR MILD TREATMENTS

Keep the applicator in close contact with the body at any part which requires a mild treatment.

Start with the weakest current possible. Avoid the initial little discharge which occurs when you bring the applicator close to the body in making the contact. Make contact quickly and the initial discharge will not be annoying. Do the same when the treatment is finished. Remove the electrode quickly. This will save you the little sparks you may otherwise feel. By no means does this little spark, when making contact with the applicator and when removing it, hurt. If you think it does, it is imaginary. Just use common sense and a little judgment and you will find that even one-half inch of High Frequency discharge does not cause any pain.

ORIFICAL TREATMENTS

All orificial electrodes must be lubricated before insertion. They should be properly sterilized. It is wrong to believe that orificial treatments are painful. There is, in fact, no other sensation than that of a beneficial warmth during the application. Orificial treatments should not last over five minutes. It is also advisable to move the electrode during the treatment just slightly so as to avoid its sticking to the mucous membrane. Orificial treatments require, for safety's sake and for better results, always two people, patient and operator. Always turn the current on after insertion of the applicator and turn the current off before removing the same. Use metal electrode No. S6 in the machine and apply to the metal cap of the orificial applicator to prevent breaking glass within the orifice.

TAKE CARE OF GLASS APPLICATORS

Cleanliness is of great importance. Inasmuch as the Violet Ray itself is germicidal in character, all applicators should, nevertheless, be kept clean so that no infection can be spread wherever several people may use the same Violet Ray Instrument. The wiping off of the electrodes on a towel or just rinsing in water is not enough. Use warm water and soap at least to guard against troubles. In cases of skin and scalp diseases, be exceptionally careful. All glass electrodes stand heating and can be boiled in water. If you intend to use some antiseptic solution for immersing the electrode, be sure that the mixture

is strong enough. Benetol, Lysol and other solutions are used especially with all orificial electrodes. Rinse these sterilized electrodes in warm water before using them.

DIRECTIONS FOR OPERATION

1. Insert the Glass Applicator into the handle of machine.
2. Attach the plug to the lamp socket.
3. Turn the current on: first, electric light switch; second, knob switch on machine.
4. Turn the adjusting knob switch to the right to increase, or left to diminish the Violet Ray discharge.
5. *In orificial treatments*, the electrode should be first inserted into the orifice without inserting it in the instrument. Then place Electrode No. S6 in the instrument. Hold this metal electrode against the metal cap of the orificial electrode. Use lubricant on all orificial electrodes. (For physicians.)
6. *In the indirect treatment*, the party to be treated should hold the instrument, with metal Electrode No. S6 held in the other hand. The current should then be turned on and some second party, with either hand, fingertips or another applicator, draw the current to the desired spot of the patient's body. This method can be used for body massage, facial massage and scalp treatment.
7. Do not attempt to repair instrument, if the necessity arises, write to the factory, advising of your difficulties and we will inform you what to do.
8. *Do not use any violet ray instrument in connection with hair tonic containing alcohol.*
9. Any treatment should be started with a mild current and gradually increased to the required strength.
10. When a treatment is completed, do not forget to turn off the current at the switch, or, to be on the safe side, *remove plug from the electric light socket*. Damage arising from carelessness is not covered in our guarantee.
11. The standard winding for this instrument is 110 volts. If voltage is higher or lower than 15 per cent, special windings or series resistances must be used to prevent damage. We will supply all necessary information upon request.
12. Take care of the connecting cords. They should be kept dry and free from knots and twists and must be repaired when signs of wear are apparent.
13. Should you break the glass Electrode off in the machine accidentally, simply take a pair of long nose pliers and pull out the broken part, after disconnecting plug from current.

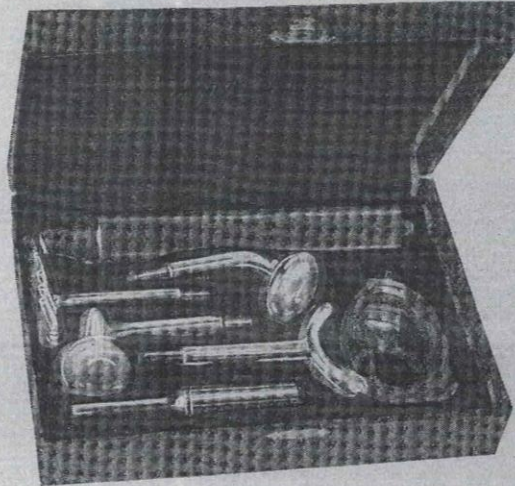

Marvel Special No. 5

Marvel Special No. 5 B

Same as above with cautery, instead of condenser electrode

The MARVEL-SPECIAL is equipped with a double vibrating spring and tension bar which permits the finest regulation from a very low to a highly powerful diffused spark, without any disagreeable kick.

This instrument is equipped with surface, comb, throat, condenser and metal electrodes. The condenser electrode is used where a very powerful penetrating ray is desired, such as, in the treatment of rheumatism, etc., and the metal electrode is used for indirect treatments. The outfit can be furnished with a fulguration electrode instead of the condenser for beauty parlor use and is then known as the MARVEL-SPECIAL No. 5B.

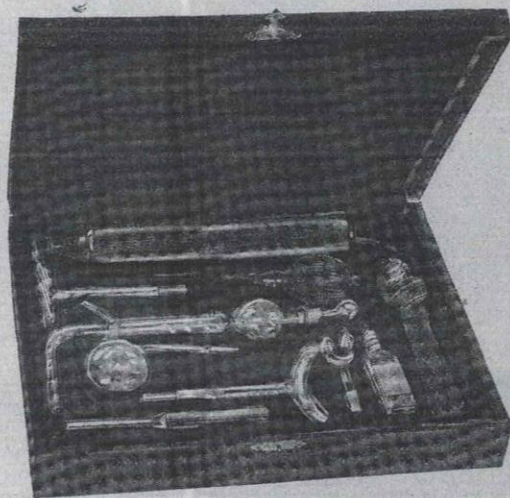

Marvel Ozone No. 7

The MARVEL-OZONE represents the last word in violet ray construction. It is wound with our specially impregnated wire which eliminates heating, running of wax and consequent lowering of efficiency which occurs in instruments where the secondary coil is baked in wax.

This instrument is encased in our "grip-tight" indestructible handle and is highly insulated. Nothing but the very finest material is used. The workmanship is the finest that can be commanded and the outfit is without comparison.

This ozone instrument is equipped with all the most popular electrodes and a complete ozone attachment.

Especially for physician or family use.

It is equipped with surface, comb, throat, metal ozone generator complete with inhalent. Packed in a stunning silk-lined case.

VIOLET RAY TREATMENTS

The following are suggestions for the treatment of disease with Violet Ray which have been taken from cases where physicians have obtained excellent results. Not all cases can be cured with Violet Ray treatment alone, but in many cases it has been found very beneficial where medical treatments have failed entirely.

Abscesses

Keep electrode No. S1 in contact with the skin. Move it gently over the whole affected area for 3-5 minutes. The current must be very mild. If applied to a developing abscess, its growth can be arrested.

Acne (Pimples)

Treat the entire surface for about 6 minute with Electrode No. S1. Where pustules are forming raise the electrode slightly to give a small spark for a short time. If many pustules are present treat through a thin towel or folded handkerchief. This has somewhat of a cauterizing effect and will soon cause the pimples to ripen and disappear. When the treatment through an interposed dry resistance, as a towel or handkerchief seems disagreeable, apply the applicator No. S1 direct, but powder the skin with talcum powder. This usually suffices to create a dry surface and at the same time prevents the sticking of the applicator to a damp skin.

Alopecia (Falling Hair)

Use a weak current at first, and increase to a medium strength later on, with electrode No. S3. Pass the comb back and forth over the entire scalp for about 4 minutes every day. Use the same treatment for baldness due to sickness and for gray hair in order to restore it to its natural color. Do not use Violet Ray immediately after using hair tonic.

Anæmia

General applications to the naked surface of the body, which should be dried and powdered with talcum powder, over the chest, abdomen, back and spine, covering the whole as thorough as possible, increase the oxygenation of the blood. Treat with No. S1 electrode for 4-6 minutes. The regenerative forces for the production of new blood cells are stimulated to greater activity by the High Frequency current. The oxygen carrying properties of the red blood corpuscles are increased. Ozone Inhalation with the Ozone Generator is very helpful. (Ozone Generator in back of book.)

Arteriosclerosis (Hardening of the Arteries, High Blood Pressure)

Daily treatments of about 5 minutes' duration will serve to lower the blood pressure. High Frequency currents have the power of making calcareous deposits soluble. Electricity seeks the path of least resistance, which, in the body, are the veins, as they contain the conductible carbonates and impurities which are most in need of purifying action. Apply electrode No. S1 or No. S2 over the body generally, using a medium current strength.

Asthma

Apply electrode No. S1 over the chest and No. S5 to throat glands for about 6 minutes. Use a strong current if it can be tolerated. Also use the Ozone Generator (in back of book). If treatment is taken when attack is near, much relief can be had and sometimes the attack can be entirely averted.

Ataxia

The current should be as strong as it can be tolerated for this treatment. Apply with electrode No. S4 or (S1) to the entire spine, over buttocks, abdomen and back legs. Daily treatments lasting about 10 minutes are necessary at first. They can be gradually decreased with the progressing improvement to about two a week.

Backache

Treat sore muscles in back through bath towel with Electrode No. S1 and cover the entire painful area. This will relieve all pain. As backache may have different causes, as weakness of the bladder or sexual organs, lumbago, rheumatism, kidney disease, it is of importance to treat the cause also.

Barbers Itch

Treat the affected area daily with No. S1 electrode for about 5 minutes. Small sparks over the whole surface and towards the edges are very helpful. Treatment through a handkerchief is advisable. You cannot remove it in one treatment, therefore be patient.

Birth Marks

Applications with No. S1 electrode repeated at convenience and often, using a medium current will, if used with judgment, remove them.

Bladder Disease (Cystitis)

Treat with electrode No. S1 or S2 with a strong current the area over the bladder for 5 minutes twice a day. The urine will clear fast. Relief is usually quick with strong current.

Boils

(See Furunculosis).

Bronchitis

Short sparks applied through a Turkish towel with electrode No. S2 over the chest and back, sufficient to produce a reddening of the skin, help wonderfully. Use the Ozone Generator for inhalations. (See back of book.)

Blackheads

A mild to medium current applied with Applicator No. S1 for 3—5 minutes at least once every day. This will soon remove blackheads. Use talcum powder or High Frequency lubricant over the area you intend to treat.

Brain Fog

Use applicator No. S1 medium current over the forehead and eyes, back of head and neck and also down the spine for about 8 minutes. Relief is sure. Ozone Inhalation for about 3 minutes will greatly help the condition and invigorate the whole system. (See Ozone Generator in back of book.)

Breast Development

Cover the entire area to be developed in your treatment. Use electrode No. S1 for about 5—7 minutes daily. Move it lightly over each side, from the neck downward and also from arm pit to arm pit, under each breast, pressing lightly upward.

Bunions

Use No. S2 or S18 electrode with medium current for about 6 minutes. Keep the applicator in contact with the skin but move it slowly over the entire painful area. It will relieve all pain.

Brights Disease

Apply with electrode No. S1 over the region of the kidneys a strong current for at least 7 minutes every day. It can be noticed that the albumen in the urine quickly disappears.

Bruises

No. S1 electrode with mild or medium current applied to the swollen or painful spot brings immediate results. A few minutes contact and gentle moving, back and forth, is sufficient.

Burns

A gentle current for a short time, say about 2 or 3 minutes, taken 2 or 3 times a day and applied with No. S1 electrode does a lot of good and tends to relieve the pain.

Callouses

Use a strong current with electrode No. S1 or apply the fulguration electrode No. S20 Spark the skin directly for 1 or 2 minutes. Repeat as necessity requires.

Cancer

Mild forms of cancer are treated with a strong spark. Surgery is usually required in conjunction. Use electrode No. S20. Treatment should be taken only under supervision of physician. It is often used in connection with X Rays.

Canker

A medium current for one or two minutes should be applied with electrode No. S10, No. 32 or any suitable dental electrode.

Carbuncles

Use applicator No. S1 for 5—6 minutes twice a day over the carbuncle, keeping it in contact with the same. A medium current strength is sufficient. Electrode No. 9 is also very convenient.

Catarrh-Nasal

Rub electrode No. S1 using a medium current, over the outer surface of nose and also the back of the neck, for about 5 minutes. Take Ozone Inhalation with the Ozone Generator (see back of book). Electrode No. S52 is successfully used in nostrils.

Cataract

Close the lids and use electrode No. S18 with a weak current for 4 minutes. Results are often surprising.

Chilblains

Treat the affected part with No. S1 electrode for 6—8 minutes. Keep the applicator in contact and use a medium current.

Cold Extremities

Use a strong current with electrode No. S2 for about 5 minutes over the entire part. Produce a reddening of the skin, keeping the applicator in contact but moving it. Repeat, if necessary, 3 times a day.

Colds in Head

Apply No. S1 electrode over nose, above eyes and the sides of face. Use a medium current about twice or 3 times a day and take also Ozone Inhalations for several minutes with the Ozone Generator. (See back of book). Ozone Inhalations are very beneficial in this case. Physicians use also successfully electrode No. S52 in nostrils.

Colds in Lungs

Treat the chest and back in the same manner as explained under Asthma. Take Ozone Inhalations repeatedly for several minutes. (See back of book).

Constipation

Apply a strong current with No. S2 over the entire abdominal area. Treat for at least 6 minutes, keeping the electrode moving at all times. Physicians use electrode No. S32, 33, 34, 35 and 36 to great advantage. These electrodes should be lubricated before insertion into the rectum. 5 minutes of orificial treatment is sufficient. Use S6 in conjunction with rectal electrodes.

Consumption

The party to receive the treatment must be stripped of all clothing to the waist line. The skin of the trunk of the body should be dried and powdered with talcum powder all over. Use electrode No. S2 and apply the High Frequency Current to the chest. Start with medium current strength and increase to heavy discharge by and by. Move the applicator also towards the throat. This starts the secretory glands to action and improves the nutrient blood-supply through the tissues. Fill your lungs as much as possible by deep breathing. Do this repeatedly. Move from chest towards both sides of body and also gastric region. Then after 5—6 minutes of front application have the back treated. A strong current should be used over the shoulder blades, the spinal nerve centers and the kidneys. Ozone inhalation using the Ozone Generator (see back of book) is of the greatest importance. It is in tubercular conditions where Ozone Inhalations do the best work.

Corns

Take electrode No. S1 or S18 and turn it on its edge so that the spark passes from its edge instead from its face and hold it about $\frac{1}{8}$ in. from the corn. Allow short sparks to pass into the corn for a few seconds only. Repeat this in a day or two. Applications with No. S18, which is hollow shaped, direct over the corn in close contact for 2 or 3 minutes are very pain-relieving.

Deafness

Ear electrode No. S10 or preferably S56 gives excellent results. Use a mild current for about 3 minutes, inserting the electrode deep into ear. If the heating effect becomes too marked, interrupt treatment and repeat at convenience. Treatments twice daily are sufficient. Applications with No. S1 to the back of the ear are also helpful.

Diabetes

If proper diet is observed and application with No. S1 or No. S2 are made over the abdomen, results are gratifying in a few weeks. Apply a strong current for about 5 minutes through a thin towel twice every day.

Dandruff

Shampoo the scalp before treatment, dry it thoroughly and apply a medium current with applicator No. S3 using it in the same manner as an ordinary comb. 3 to 5 minutes are sufficient. Repeat this treatment at intervals of 2—3 days. Do not use any hair tonic.

Dyspepsia

Use electrode No. S1 or preferably No. S2 over the region of the stomach. Daily applications of 6 minutes will in most cases show considerable improvement. A strong current is necessary. Decrease treatment gradually, do not entirely stop with them at once.

Earache, Ear Diseases

Insert electrode No. S10 and use a mild current for short periods of time. Applications to the back of the ear with No. S1 assist this treatment greatly. It may in some cases be necessary to take hourly applications. The circumstances have to dictate this necessity. If heating effect during treatment is too marked, interrupt application and repeat it at convenience.

Eczema

Lay a handkerchief or piece of thin cloth over the affected area and treat with electrode No. S1 through the same with a mild current at first. Increase the current strength during the treatment if it can be tolerated. If the skin itches—lift the electrode slightly from the cloth. This will bring quick relief. Daily treatments lasting 3—5 minutes effect a cure in nearly all cases.

Epilepsy

Use electrode No. S1 in contact over the brain and electrode No. S4 along the spine, moving it up and down. A medium discharge for 5—7 minutes is sufficient. Repeat every other day.

Eye Diseases

Iritis, Redinitis, Atrophy of the Optic Nerve, Conjunctivitis, Trachoma, Glaucoma, Incipient Cataract, Paralysis of Ocular Muscles, Intra-ocular Hemorrhage have been successfully treated by the Violet Ray High Frequency current. Close eyelids and apply a mild current with electrode No. S18 No. S39 for short periods, not exceeding 3 minutes at one time. Repeat as desirable.

Falling Hair

(See Alopecia)

Felons

Treat with No. S1 electrode and a mild current in close contact daily from 4—6 minutes.

Female Troubles

Physicians use electrodes No. S13, S30 and No. S31. They should be lubricated before insertion. A medium current for 5 minutes is applied. Repeat treatment as circumstances require. During menstruation an excessive flow of blood may result as High Frequency currents draw the blood. Turn the current on after insertion of electrode and turn the current off before removing the electrode to avoid unnecessary sparking. (See technique.)

Electrode No. S6 should always be used in conjunction with official electrodes.

Fistulas

Use electrode No. S14-33-35-36 as indicated. Lubricate before insertion into rectum. Use a medium current for about 5 minutes daily.

Electrode No. S6 should always be used in conjunction with official electrodes.

Flabby Breast

Apply No. S1 electrode to whole surface of breast with medium current for 4—6 minutes every day.

Freckles

Cover surface with gauze. Use electrode No. S1 daily from 4—6 minutes with a medium current. Results are apt to be slow, therefore be patient.

Frost Bites

No. S1 applicator with a medium current strength, allowing short sparks to pass to the affected parts for about 3—5 minutes every two or three hours brings lasting results in a short time.

Furunculosis

Boils, treat with No. S1 electrode. Mild or medium current strength. Inflammation ceases quickly.

Goitre

Many cases yield to application with No. S5 Electrode, using the strongest current that can be tolerated. It can be treated direct by making contact with the electrode. Sometimes it is treated through gauze. The later way is more recommendable. Do not treat longer than 4 minutes at a time every day. Results are usually not apparent until after the 10th or 12th treatment.

Gout

Apply electrode No. S1 to painful area with medium current keeping the applicator in contact but moving it slowly about. The pain may increase at first but relief will be felt after a few treatments.

Gray Hair

The natural color of hair can often be restored by patient treatments with Electrode No. S5. See under Alopecia. Sometimes 2 months are required for first results. Keep the scalp clean. Use a current of sufficient strength for good stimulation every day once or twice.

Grippe (Influenza)

Cover the spine and solar plexus with applications by No. S1 electrode. Also treat over the eyes and sides of nose. Treatments to spine and solar plexus should be made through a turkish towel for 5—7 minutes and repeated twice a day if necessary. Intra-nasal applications of short duration with Electrode No. S10 and a weak current are often given by physicians in addition to the mentioned treatment.

Hay Fever

Apply electrode No. S1 over the nose and along spine with medium current for 5 minutes and No. S10 or No. S28 in nostrils for short period of time. Applications should be of short duration but often repeated. It is advisable to anticipate the trouble and to begin treatments before attacks are expected or discomfort felt. Ozone treatments are of the greatest benefit.

Headaches

They are from varying causes. If relief is not felt by applying No. S1 electrode to the seat of the headache, cover the stomach and spine by treatment, using a medium current for 5—7 minutes.

Hives and Rash

Use electrode No. S1 with medium current strength to affected area. Use High Frequency Lubricant before applying the electrode. 3—5 minutes should be sufficient. Repeat daily.

Infantile Paralysis

If this disease leaves muscles feeble and weak High Frequency applications help wonderfully well to make them grow again. Use No. S1 electrode with medium or strong current for 5—7 minutes. Apply in direct contact and move the applicator over the entire area to be developed.

Inflammations

Can be reduced and relieved by application with applicator No. S1. Move it slowly over the inflamed area, keeping it in close contact. Use a medium current strength for 5—6 minutes.

Influenza

(See Grippe.)

Insomnia

Cover the back of the head, neck and eyebrows by application with electrode No. S1. A strong current is essential in treating this ailment. 5—7 minutes should be the average length of treatment.

Impotence

The most beneficial way of treating this condition is by the use of the prosthetic tube No. S-9, with plenty of spark. Use surface electrode No. S-1, slightly raised over the area of the genital and spine for 5—7 minutes daily. Special information on weakness of the organs of sex is given elsewhere in this book.

Leucorrhoea

Follow the directions given under female troubles. Also use electrode No. S4, moving it up and down the spine slowly. A strong current must be used for about 5—6 minutes every day. This treatment should only be an adjunct to medicinal treatment and physician's care.

Lumbago

Since the object is to relieve pain, treat the painful areas with Electrode No. S2 until all pain is dispelled. Repeat treatment whenever pain appears until cured.

Massage

Let patient hold metal Electrode in one hand, turning on current after it has been grasped. Masseur's fingers will draw spark to point massaged.

Mumps

Treat swollen parts. Use Electrode No. S1.

Nervousness

Treat spine, back of head and neck. Immediate results will be felt.

Neuralgia

Apply to seat of pain, raising the Electrode occasionally to produce spark.

Neuritis

The first few treatments usually increase the pain after which relief is felt, and the current may be increased and a short spark given. Apply at the seat of pain. Use electrode S1, S2.

Obesity

Apply electrode No. S1 to affected parts and treat consistently. Begin as indicated and increase current as strong as tolerable. Fat will decrease and redistribute, giving greater comfort.

Pains

The pain-relieving quality of the High Frequency current is wonderful. Apply electrode No. S1 to the seat of pain until relief is felt. Close contact is best. Medium current strength and sometimes strong currents are advised.

Paralysis

Apply No. S1 electrode along the affected muscles. A strong current is necessary. Keep the electrode moving. Treat for about 6 minutes at a time. Lubricate the affected part so that the electrode slides easily. Sparks through a turkish towel help quickly. Use this method every day.

Phthisis

(See Consumption.)

Piles (Hemorrhoids and other rectal diseases)

Are treated best with applicators No. S14, No. S35, No. S33, No. S34, No. S36. Lubricate electrode before insertion with High Frequency lubricant. Use a medium current for about 3 minutes not more than once a day. Electrode S6 should always be used in conjunction with others.

Pimples (Acne Vulgaris)

(See Acne.)

Pleurisy

Use preferably electrode No. S2. Cover the back and the chest by a vigorous treatment through a turkish towel until the skin becomes quite red. Keep the electrode moving and treat for about 8 minutes. High Frequency is an adjunct only in cases of serious sickness and nobody should fail to consult the proper authority.

Pneumonia

Ozone inhalation, repeated often with the Ozone Generator (see Electrode Catalogue) is very beneficial. Otherwise apply the same treatment as given under Pleurisy. Remember that High Frequency as an adjunct can help greatly and often do wonders, but in all grave diseases the consultation of an authoritative physician should and must be resorted to.

Poison Ivy

Apply High Frequency lubricant first. Use No. S1 or No. S2 electrode edgewise so as to cause plenty of sparking over the whole affected area. Lift the applicator here and there and treat with a strong current for 3—5 minutes. Relief is sure and surprising.

Pyorrhea

Applications with electrode No. S10 or S58 with a weak or medium current help greatly to re-establish a healthy condition of the gums. A removal of deposits is necessary, however, by mechanical and surgical means in order to fight this disease. A dentist must be consulted. High Frequency treatments promote proper nutritional improvements and in addition to this have antiseptic and anti-toxic properties.

Red Nose (Acne Rosecea)

Use preferably electrode No. S1 and apply only short periods, say about 2 minutes, small sparks by holding the electrode edgewise or lifting it somewhat about an eighth of an inch. The object is to destroy the enlarged veins. The treatment must not be carried too far at one time. It should be repeated as the condition permits. Several days' rest between treatments may sometimes be advisable.

Rheumatism

Strong currents have to be used in all cases of Rheumatism. This disease responds quickly, especially cases of the muscular and chronic articular form. In acute cases of this ailment the results are slower but nevertheless satisfactory. The affected parts should be treated until all pain ceases. Changing the position of parts or extremities being treated will likely expose other parts requiring treatment. Put muscles on the stretch and use High Frequency current long enough to dispell all discomfort. Applicator No. S2 is especially recommended for these treatments. Repeat these applications as often as pain reappears. 10 minutes' use of the instrument at one time is usually enough. The applicator can be used in close contact but most cases require treatment through clothing or several layers of a towel.

Ringworm

Use electrode No. S1 and apply short sparks for several minutes two or three times every other day. A medium current is sufficient. Move the electrode so as to cover all the affected area.

Scalp Treatment

Dandruff, falling hair, gray hair, baldness, itching scalp, etc., are very successfully benefited by Violet Rays. There is no question that the Violet Ray represents the most scientific method of treating the scalp. Its beneficial value is beyond all doubt.

Violet Rays produce a normal and healthy scalp, revitalize impoverished hair, restore its natural lustre and fullness. They bring in new hair by causing additional nourishment to flow to the dormant papilla.

Use electrode No. S3 every day one to three times for several minutes. Do not use any hair tonic. Violet Rays constitute the best hair tonic themselves.

In baldness the Violet Ray proves to be of a very welcome and effective assistance to restore the natural growth of hair. The results are very satisfactory. Conscientious use of Violet Ray High Frequency Current and patience have here, as in many other instances, surprised many people.

Gray hair has been restored to its original color and beauty in many cases. We do not claim too much by saying that scalp applications with electrode No. S3 are the only reliable means at the present time to stimulate and assist natural growth of hair.

Scars

The object is to destroy the scar tissue so that new tissue may form. Use therefore a strong spark. Apply either electrode No. 1 edgewise, or still better use electrode No. S10 with the necessary care. A few minutes, sometimes only seconds will suffice in certain cases where the scar is small and not too old. Judgment should be used.

Sciatica

Is an affection of the great sciatic nerve trunk. Its cause is found in neuralgia and also sometimes in rheumatism. The sciatic nerves run down the thigh from hip to knee. They lie near the bones deep under the heavy muscles. Sometimes they become so inflamed and tender that even the slightest pressure causes an extreme pain. A counter-irritating discharge applied through the clothing or over the painful area with electrode No. S1 or No. S2 will bring quick relief.

Skin Disease

In all skin diseases the High Frequency spray (small sparks) is most success-

fully applied. Electrode No. S1 is sufficient in nearly all cases. It should be passed rapidly back and forth over the affected area for several minutes. If the skin is moist, talcum powder should be used so that the electrode will not stick. Another easy method is to spread gauze over the part to be treated. This will enable the user of the instrument to move the electrode smoothly and at the same time does not remove it far enough to cause an unpleasant spark. Where itching is very marked longer and sharper sparks are best. Apply these only for short periods. Epithelioma, Lupus and Chronic Ulcers can be treated in the same manner.

Stiff Neck and Joints

Apply in the same manner as explained under "Neuritis." Use a longer treatment if necessary. In cases of Torticollis (stiff neck) rub the No. S1 electrode frequently along back of ear and down the neck on both sides for 3-5 minutes.

Sore Feet and Stone Bruises

Applications with any suitable applicator in close contact with the skin bring quick relief. Use High Frequency lubricant and treat for several minutes.

Sore Throat

Electrode No. S5 is best suited for external throat applications. High Frequency lubricant should be used and the electrode moved up and down the throat in close contact, covering all parts well for 5 or 6 minutes, with a medium or strong current; repeat 2 or 3 times a day in some obstinate cases.

Sprains

Close contact applications with a surface applicator prove helpful. Use a medium current and in cases of long standing use small sparks or treatment through towel. 4 or 5 minutes usually suffice. Repeat as circumstances indicate.

Tonsillitis

Use No. S5 electrode and apply in the same manner as explained under "Sore Throat." Physicians use electrode No.

S58 internally with fine success. Ozone inhalation with Ozone Generator (see Electrode Catalogue) assist greatly.

Tuberculosis

(See Consumption.)

Ulcers

Apply a strong current with No. S2 or No. S5 electrode for 5 minutes in contact, lifting the applicator once in a while to produce sparks of at least one-quarter inch. Repeat this treatment every day.

Warts

Take electrode No. 1, hold it about one-eighth or three-sixteenths inch from warts and allow sparks to pass from the edge of the glass. For the best results use electrode No. S20. Let the Platinum point rest directly on top of the wart and use a weak current. Pass a stronger current through the deeper crustation. A few seconds are usually sufficient. Wait 2 or 3 days for results and repeat operation if necessary.

Whooping Cough

Apply No. S1 electrode in the same way as explained under "Asthma" and use also Ozone Inhalation with the Ozone Generator. (See Electrode Catalogue.)

Writers' Cramp

Apply No. S1 electrode with medium current for about 6 minutes from finger tips along back of hand and arm to shoulder and spine. This treatment can also be made through a towel if it can be tolerated.

Wrinkles

Are commonly caused by using a given set of facial muscles more than normally. They can be removed by applying Electrode No. S1 right over them with a rotary, massaging movement. High Frequency current revitalizes tired muscles and arrests the blighting marks of time.

For those who desire more exhaustive information on High-Frequency currents we recommend:

N. M. Eberhart, M. D., Ph. D., D. C. L., Manual of H. F. Currents, \$4.00.

We have copies of the above Manual in stock.

Violet Ray Electrodes



No. S-1 Surface electrode \$1.00



No. S-2 Large condenser electrode, deliver strong current for Rheumatism, Lumbago, etc. \$3.00

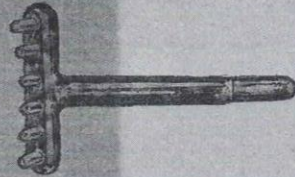

No. S-3 Comb electrode for scalp \$1.50

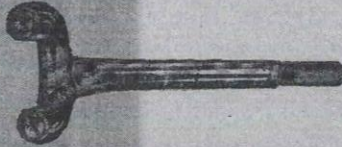

No. S-4 Spinal electrode \$2.00

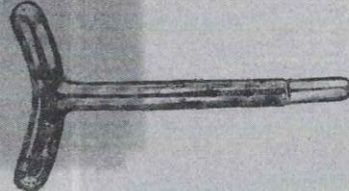

No. S-5 External throat electrode, also excellent for the neck, arms and limbs \$1.00



No. S-6 Metal handle used for giving indirect treatments \$1.25



No. S-9 Insulated prostatic electrode.....\$2.00



No. S-10 Plain internal throat electrode, or ear electrode.....\$1.00



No. S-56 Insulated ear electrode.....\$2.00



No. S-58 Insulated internal throat electrode.....\$2.00



No. S-13 Plain vaginal.....\$1.00

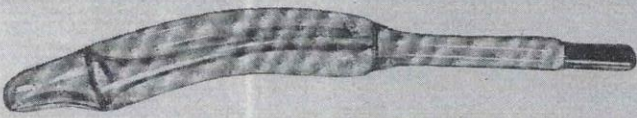

No. S-30 Insulated vaginal electrode, large diameter.....\$2.00



No. S-31 Insulated vaginal electrode for generation of ozone within the vagina.....\$3.00



No. S-14 Plain rectal electrode, small diameter.....\$1.00

No. S-33 Plain rectal, large diameter.....\$1.00

No. S-35 Plain rectal, medium diameter.....\$1.00



- No. S-32 Insulated rectal, large diameter \$2.00
- No. S-34 Insulated rectal, medium diameter \$2.00
- No. S-36 Insulated rectal electrode, small 2.00



- No. S-18 Eye electrode, also used for corns \$1.00
- No. S-39 Double eye electrode 2.00



- No. S-20 Fulguration electrode for removal of warts, moles, diseased growths, etc. \$2.00



- No. S-38 Hollow surface shaped, generates ozone within cavity and fits nicely over certain parts as cheekbones \$1.25



- No. S-41 Dental Electrode for Gum treatment, Right side of Jaw \$2.00
- No. S-42 Dental Electrode for Gum treatment, left side of Jaw 2.00
- No. S-43 Dental Electrode for Gum treatment inside of Jaw 2.00
- No. S-44 Dental Electrode for front Gum treatment 2.00
- No. S-45 Dental Electrode for inside of Jaw 2.00
- No. S-46 Insulated Electrode covers small 2.00



- No. S-49 Dental Abscess Electrode \$1.00
- No. 50 Insulated Urethral Electrode \$2.00

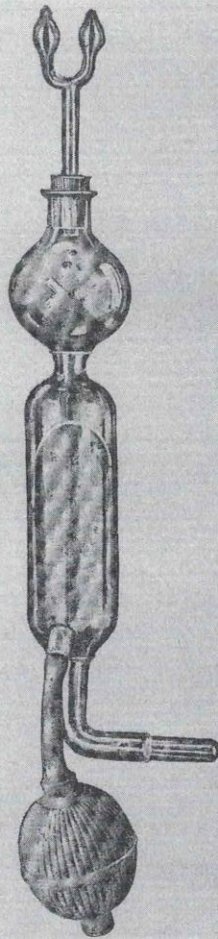

OZONE GENERATOR

This instrument generates enormous quantities of Ozone, which is purified by passing through the inhalant which is provided. A piece of cotton is saturated with this inhalant and placed in the receptacle. Squeezing the rubber bulb forces the Ozone bubbles through this mixture and is inhaled in the form of a vapor.

It should be inserted the same as any other electrode, and the machine supported on a table. The hand must be in contact with the glass stem of the generator while in use.

The Ozone permeates every cell in the lungs, destroying any germ life and soothing the inflamed tissues. For Anemia, Hay Fever, Coughs, Catarrh, Asthma, Bronchitis, Insomnia, Nervous Debility and Tuberculosis of the Lungs, there is no better treatment.

The treatments are exceedingly agreeable and remind one of a trip to the pine woods.

Price complete with all the attachments and one bottle of inhalant.

No. S-28 Ozone generator, complete with 1 oz. bottle of inhalant,
nose and mouth-piece and bulb..... \$10.00
Extra Inhalant 1.00

The Eastern Laboratories, Inc., will be pleased to furnish, upon application, any special electrodes that may be needed.

NOTE: Damages arising from carelessness are not covered by our guarantee. If instructions are properly followed the instrument will last indefinitely.

Unless otherwise specified all machines will be furnished to operate on standard voltage of 110 to 120 volts. Machines can also be furnished to operate on 220 volts and 32 volts.

Marvelite

THERAPEUTIC LAMPS



We cannot, too strongly, recommend the use of our Therapeutic Lamps in connection with the violet ray treatment. The rays developed by these lamps penetrate deep into the flesh, greatly stimulating glandular activity. The opening of the pores, due to the heat rays, give the high frequency current ready access to the part in treatment. The combined actions of the heat, light and high frequency current, have a pronounced germicidal effect and is especially recommended for pimples, boils, eczema, barber's itch and such conditions which involve the skin.

On the following pages we have illustrated two types of lamps, both of which have been successfully used in connection with the violet ray.

The lamp should be permanently fastened and is preferably mounted on one of our telescoping and collapsible stands. This will hold the lamp absolutely rigid and in the desired position, leaving the operator or patient free to apply the violet ray machine.



Marvelite No. 99
List Price \$10.00

The Marvelite No. 99 Therapeutic Lamp has been carefully designed, both mechanically and electrically and embodies many unique features. The entire lamp is made of one piece of aluminum, insuring both lightness and unusual strength and ruggedness. The reflector has been so designed to eliminate the customary focus point and insure a beam of parallel rays of uniform intensity over the entire area.

The Marvelite No. 99 is equipped with 7 feet reinforced cord and one 260-watt carbon lamp.

Marvelite Stand \$6.00

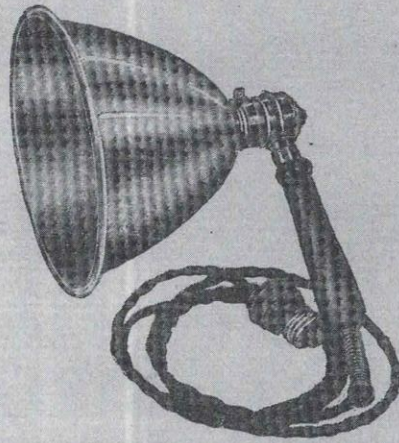

Marvelite Junior No. 97

(Red, White and Blue, 16 C. P. Lamp)

List Price \$7.00

The Marvelite Junior, No. 97, complete with seven feet of reinforced cord and three 16-candle power lamps, red, white and blue.

The Marvelite Junior Therapeutic Lamp is constructed of highly polished aluminum, extremely light in weight, making it an ideal lamp for beauty parlor work and home treatment. Aside from its therapeutic value, this lamp is of great assistance in hair drying, mud packs, oil shampoos, bleaching, etc.

The Marvelite Junior No. 98, same as No. 97, but equipped with one 100-watt carbon lamp.

List Price \$7.00



28 APPENDIX J RAILROAD GROWTH IN THE U.S. BY DECADE

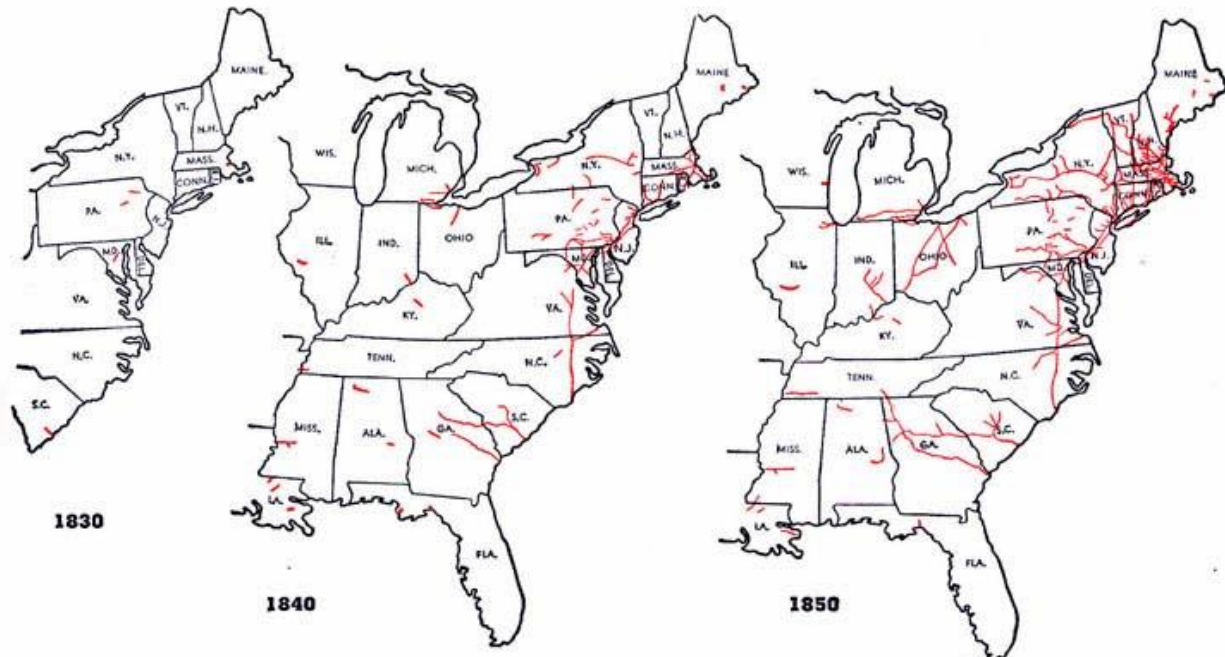

The early stages of railway development in America are shown by this set of maps. During the decade 1830-1840, the total length of completed railroad lines increased from 23 to 2,809 miles, and during the next ten years, more than 6,200 miles of railroad were opened, bringing the total network up to 9,021 miles in 1850. The most intensive growth during this period was in the Atlantic and Seaboard states. In 1850, a trip from Boston or New York to Chicago was made by rail and lake steamers or by stagecoaches, and required several days. One could travel all the way from Boston to Wilmington, North Carolina, by rail, with several changes of cars and a few ferry trips en route. During the first twenty years of railway development, covered by these maps, the population of the United States nearly doubled.



1860—This map shows the extent of railway development just prior to the Civil War. The decade 1850-1860 was a period of rapid railway expansion, characterized by the extension of many short, disjointed lines into important rail routes. This decade marked the beginning of railway development in the region west of the Mississippi River. By 1860, the "Iron Horse" had penetrated westward to the Missouri River and was beginning to make itself felt in Iowa, Arkansas, Texas, and California.

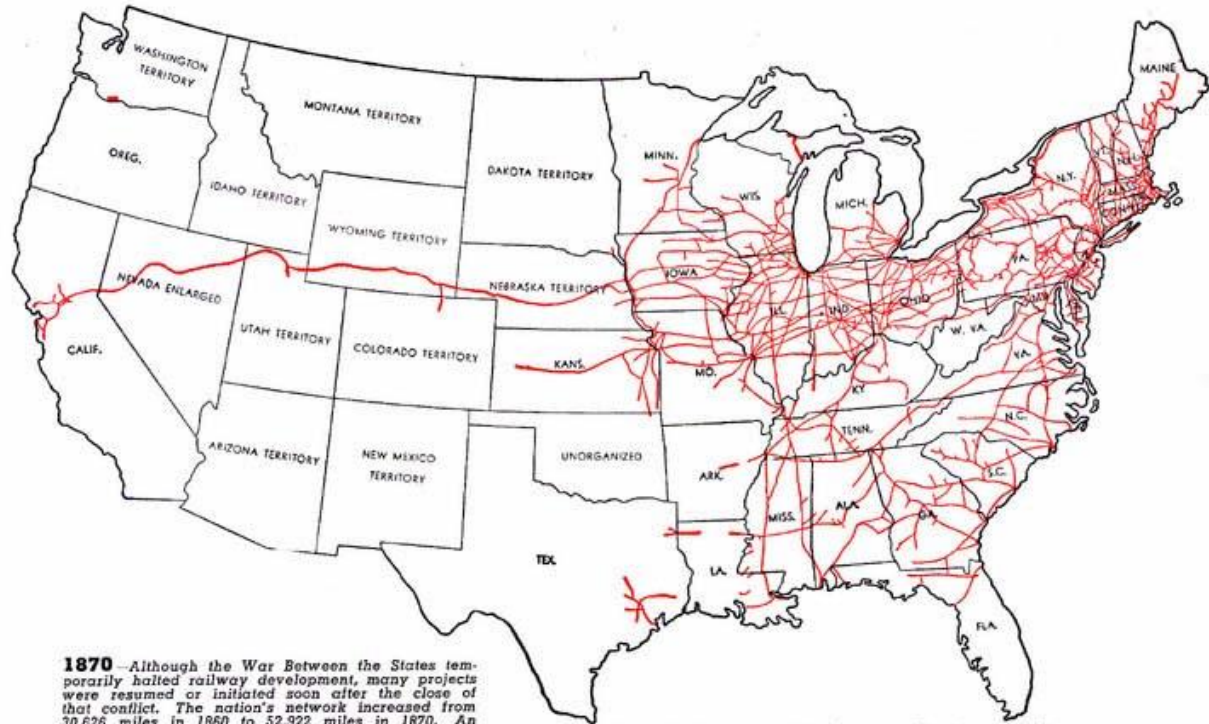

1870—Although the War Between the States temporarily halted railway development, many projects were resumed or initiated soon after the close of that conflict. The nation's network increased from 30,626 miles in 1860 to 52,922 miles in 1870. An outstanding development of the decade was the construction of the first railroad to the Pacific Ocean, making it possible for the first time to travel all the way across the country by rail. Railway development in the Mississippi and Missouri valleys was especially notable during this period.



1860—In the ten-year period prior to 1860, some 40,500 miles of railroad were built, bringing the total network up to 37,257 miles. In 1860, every state and territory was provided with railway transportation. A second line of railroads to the Pacific was nearing completion, and other transcontinental railroads were under construction. Railway development was exerting a powerful influence upon immigration and agricultural and industrial growth throughout the country.

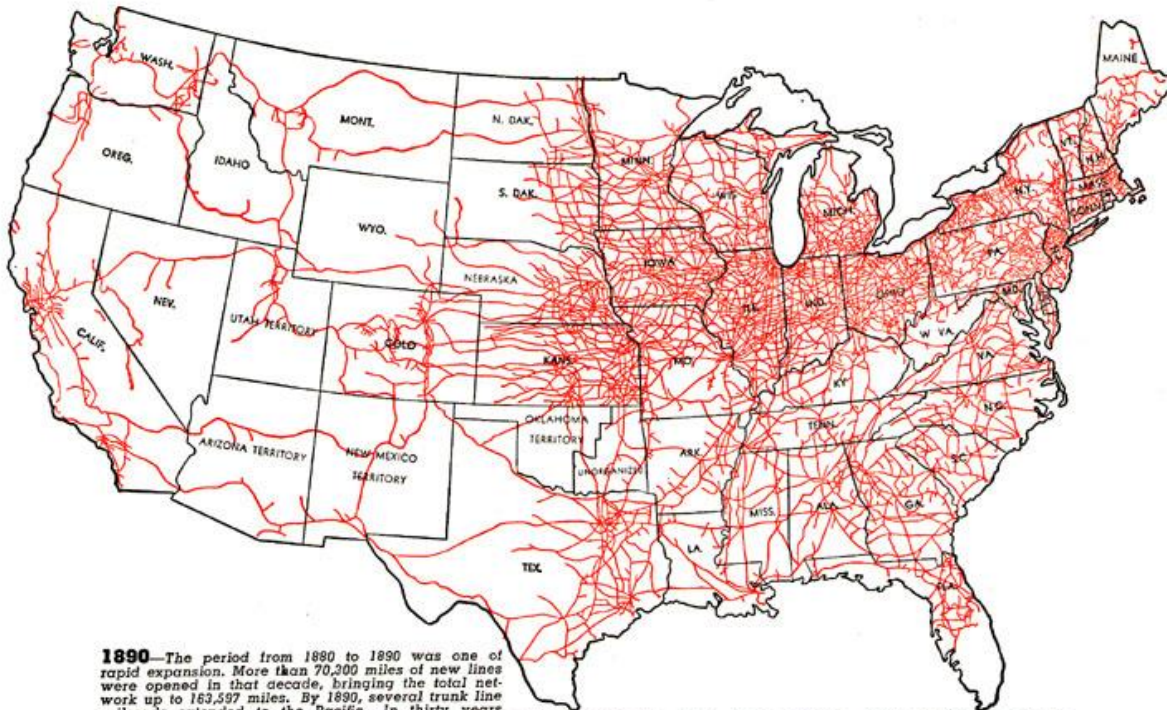

1890—The period from 1860 to 1890 was one of rapid expansion. More than 70,000 miles of new lines were opened in that decade, bringing the total network up to 163,597 miles. By 1890, several trunk line railroads extended to the Pacific. In thirty years from 1860 to 1890, the total mileage of the region west of the Mississippi River increased from 2,175 to 72,389, and the population of that area increased fourfold.

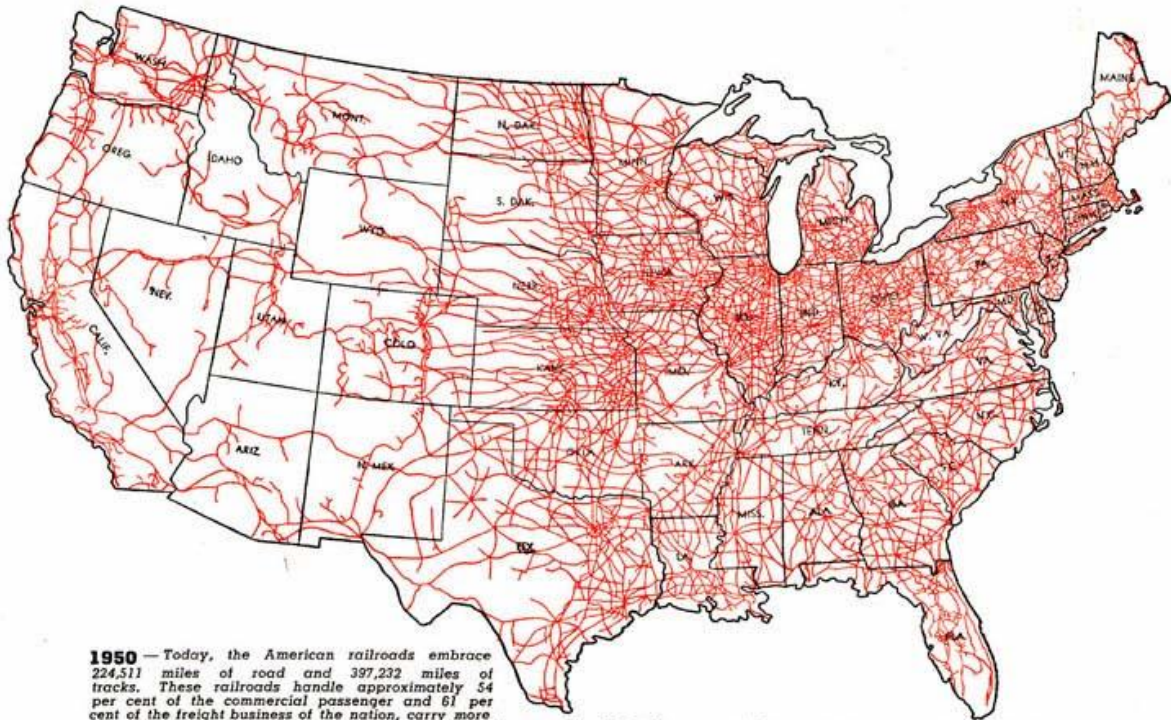

1950 — Today, the American railroads embrace 224,511 miles of road and 397,232 miles of tracks. These railroads handle approximately 54 per cent of the commercial passenger and 61 per cent of the freight business of the nation, carry more than 97 per cent of the United States mail, and perform nearly all of the commercial express traffic of the nation. During World War II these railroads handled more than 90 per cent of the war freight and 97 per cent of the organized troop movements.

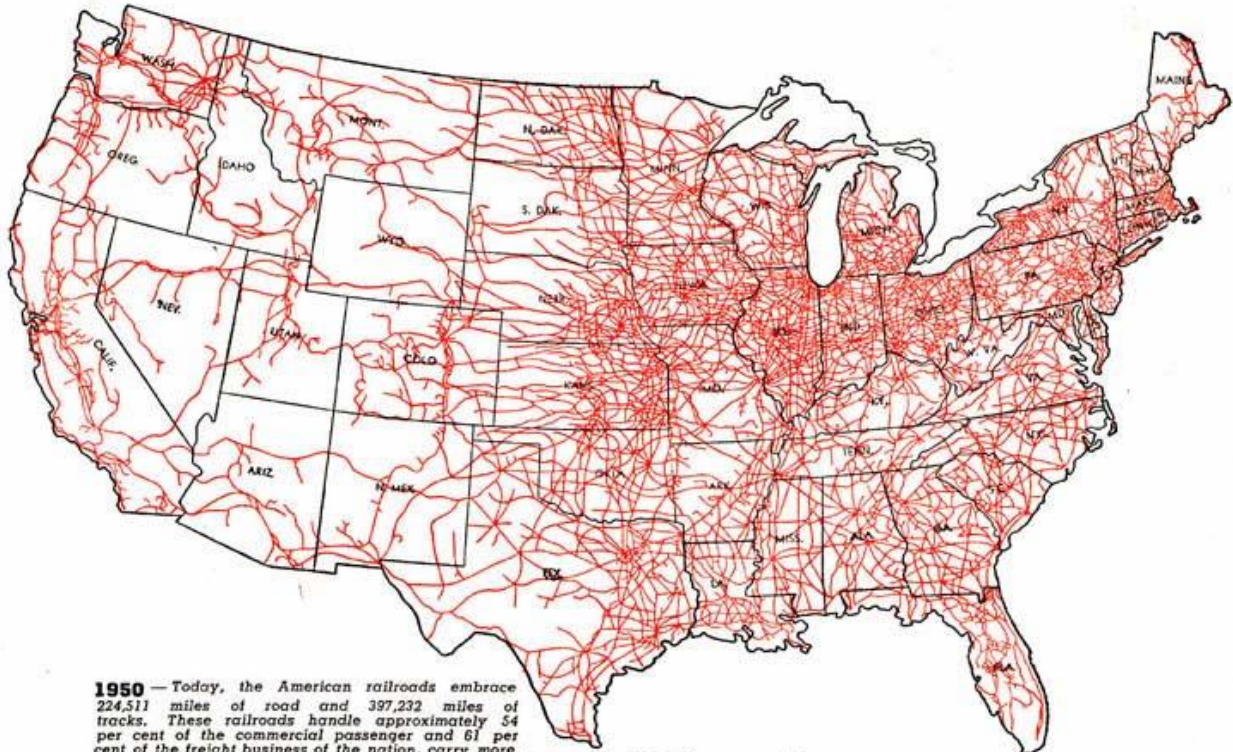

1950 — Today, the American railroads embrace 224,511 miles of road and 397,232 miles of tracks. These railroads handle approximately 54 per cent of the commercial passenger and 61 per cent of the freight business of the nation, carry more than 97 per cent of the United States mail, and perform nearly all of the commercial express traffic of the nation. During World War II these railroads handled more than 90 per cent of the war freight and 97 per cent of the organized troop movements.

For ease of reading I have included, here, in larger print the legends from the pictures above:

1830-1850: The early stages of railway development in America are shown by this set of maps. During the decade 1830-1840, the total length of completed railroad lines increased from 23 to 2,600 miles and during the next 10 years more than 6,200 miles of railroad were opened, bringing the total network up to approximately 9000 miles in 1850. The most intensive growth during this period was in the Atlantic and Seaboard states. In 1850 a trip from Boston or New York to Chicago was made by rail and lake steamers or by stagecoaches and required several days. One could travel all the way from Boston to Wilmington, North Carolina by rail with several changes of cars and a few ferry trips en route. During the first 20 years of railway development, covered by these maps the population of the United States nearly doubled.

1860: This map shows the extent of railway development just prior to the Civil War. The decade 1850-1860 was a period of rapid railway expansion, characterized by the extension of many short, disjointed lines into important rail routes. This decade marked the beginning of railway development in the region west of the Mississippi River. By 1860, the "Iron Horse" had penetrated westward to the Missouri River as was beginning to make itself felt in Iowa, Arkansas, Texas and California.

1870: Although the war between the states temporarily halted railway development, many projects were resumed or initiated soon after the close of that conflict. The nation's network increased from approximately 30,600 miles in 1860 to about 52,900 miles in 1870. An outstanding development of the decade was the construction of the first railroad to the Pacific Ocean making it possible, for the first time, to travel all the way across the country by rail. Railway development in the Mississippi and Missouri valleys was especially notable during this period.

1880: In the 10-year period prior to 1880 some 40,000 miles of railroad were built, bringing the total network up to approximately 93,400 miles. By 1880 every state and territory was provided with railway transportation. A second line of railroads to the Pacific was nearing completion, and other transcontinental railroads were under construction. Railway development was exerting a powerful influence on immigration and agricultural and industrial growth throughout the country.

1890: The period from 1880 to 1890 was one of rapid expansion. More than 70,000 miles of new lines were opened in that decade, bringing the total network up to approximately 163,600 miles. By 1890, several trunk line railroads extended to the Pacific. In 30 years from 1860 to 1890 the total mileage of the region west of the Mississippi River increased from 2175 to about 75,400, and the population of that area increased fourfold.

1950: Today, the American railroads embrace 224,500 miles of road and about 3976,250 miles of tracks. These railroads handle approximately 54% of the commercial passenger and 61% of

the freight business of the nation, carry more than 97% of the U.S. mail, and perform nearly all of the commercial express traffic of the nation. During WW II, these railroads handled more than 90% of the war freight and 97% of the organized troop movements.

2014: In the 64 years since 1950, The picture of the railroad network in the United States has changed dramatically. The total miles of track has decreased to approximately 196,000 miles, about what it was in 1860. The railroads do not carry the US mail, and competition from trucking companies has cut into the freight business. Freight is still the largest business for the railroads, with AMTRAC, a separate entity operating the passenger service, which has decreased substantially due to privately owned automobiles and the increase in air travel. Surprisingly, it took Congressional action to allow the railroads to compete with the Trucking companies.

As the industry matured, some railroads merged, and others went out of business. Many of the railroads that no longer operate are forged in this country's history, including:

- Atchison, Topeka & Santa Fe
- Baltimore & Ohio
- Chicago & Northwestern
- Erie Railroad
- Missouri Pacific
- New York Central
- Pennsylvania Railroad
- Reading Railroad

It is interesting to note that while the railroad industry, as a whole, adopted the Standard Gauge track width of 4 ft 8 1/2 inches, there are still two narrow-gauge railroads operating in the United states: Durango and Silverton Railroad in Colorado and the White Pass and Yukon in Alaska. Both have a 3-foot track width.

29 APPENDIX K BRITMAN PATENT 777,833

No. 777,833.

PATENTED DEC. 20, 1904.

C. F. BIRTMAN.
STATIC ELECTRICAL MACHINE.
APPLICATION FILED FEB. 6, 1904.

NO MODEL.

4 SHEETS—SHEET 1.

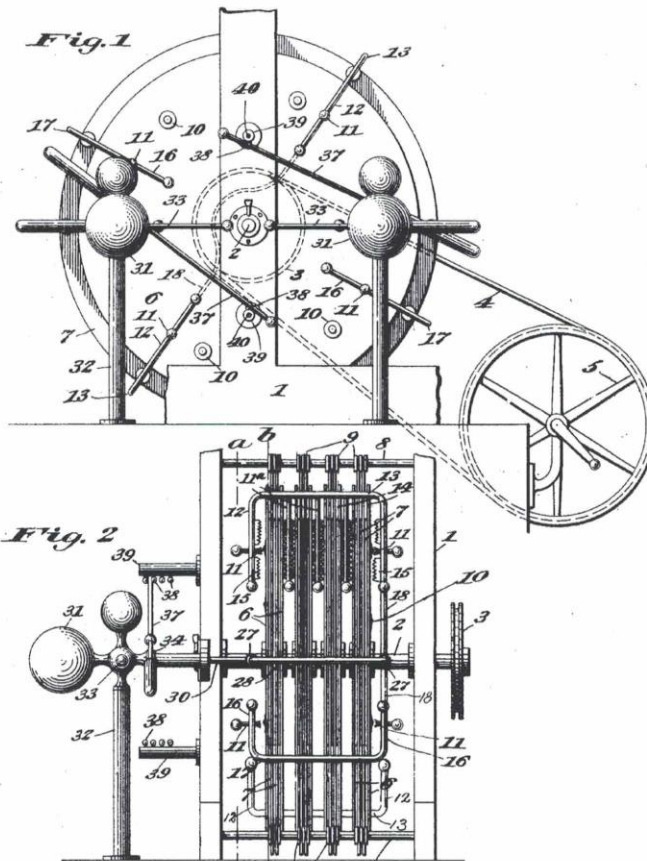

Witnesses
J. Capluque
A. Gustafson
 Inventor
Charles F. Birtman
 By *Chas. C. Hillman*
 Attorney

C. F. BIRTMAN.
STATIC ELECTRICAL MACHINE.
APPLICATION FILED FEB. 6, 1904.

NO MODEL.

4 SHEETS—SHEET 2.

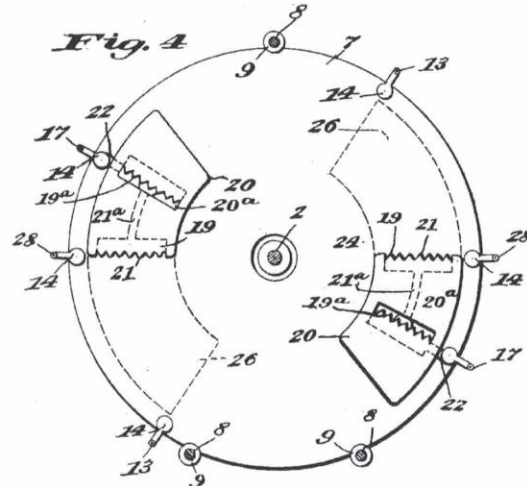
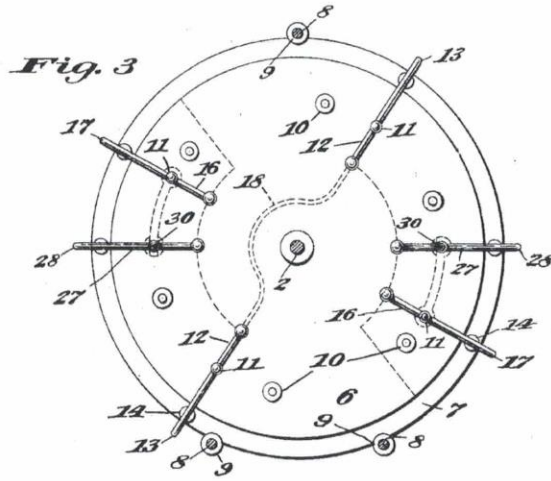

Witnesses
J. Kaplan
A. Gustafson

Inventor
Charles F. Birtman
 By *Chas. F. Birtman*
 Attorney

C. F. BIRTMAN.
STATIC ELECTRICAL MACHINE.

APPLICATION FILED FEB. 6, 1904.

NO MODEL.

4 SHEETS—SHEET 3.

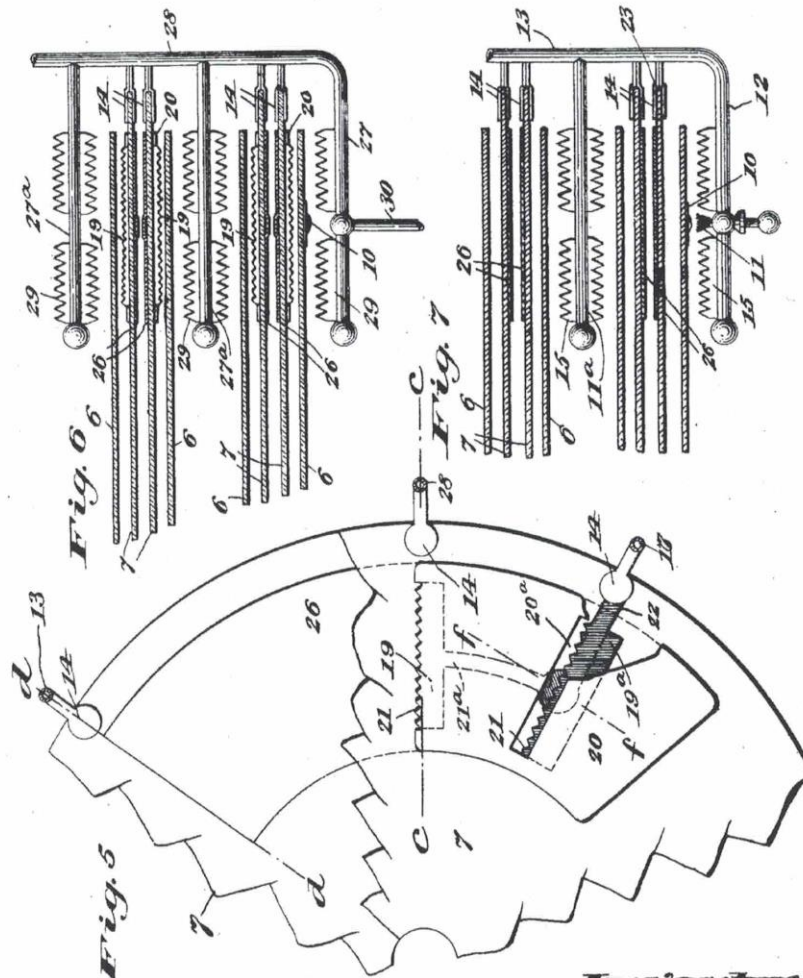

Witnesses
J. H. Caplinger
A. Gustafson

Inventor
Charles F. Birtman
 By *Chas. A. Pittman*
 Attorney

C. F. BIRTMAN.
STATIC ELECTRICAL MACHINE.

APPLICATION FILED FEB. 6, 1904.

NO MODEL.

4 SHEETS—SHEET 4.

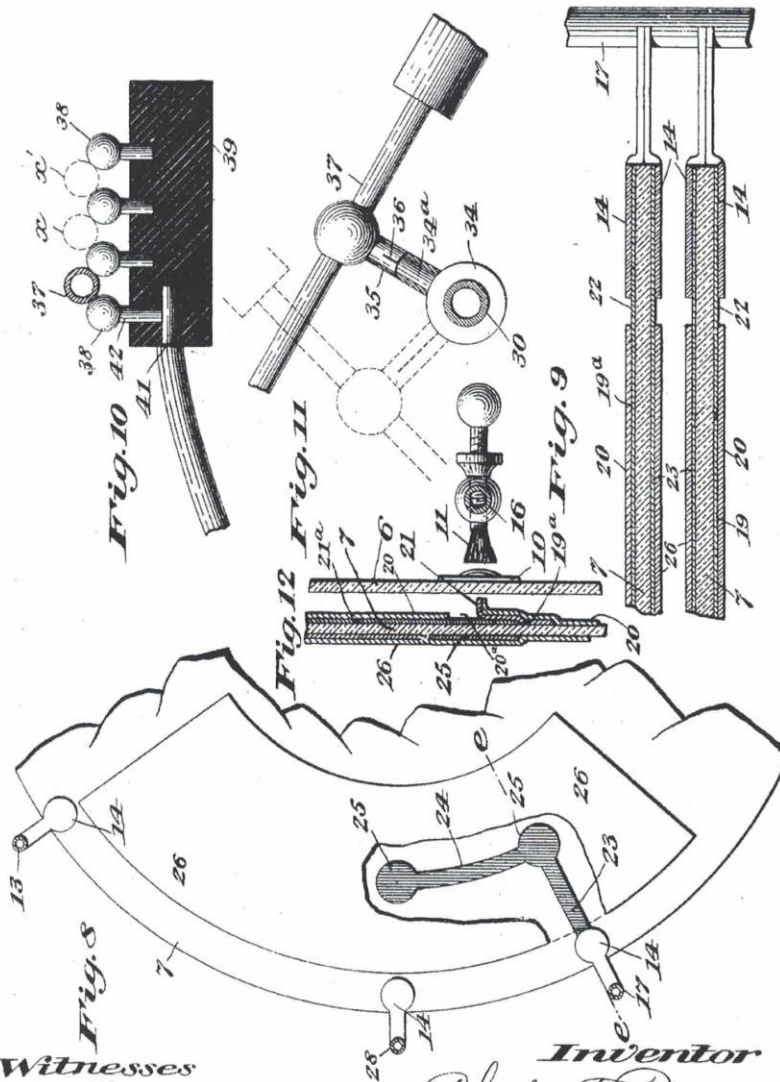

Witnesses
J. K. Caplunig
A. Gustafson

Inventor
Charles F. Birtman
 By *Chas. O. Filtman*
 Attorney.

UNITED STATES PATENT OFFICE.

CHARLES F. BIRTMAN, OF CHICAGO, ILLINOIS.

STATIC ELECTRICAL MACHINE.

SPECIFICATION forming part of Letters Patent No. 777,833, dated December 20, 1904.

Application filed February 6, 1904. Serial No. 192,272.

To all whom it may concern:

Be it known that I, CHARLES F. BIRTMAN, a citizen of the United States of America, and a resident of Chicago, in the county of Cook and State of Illinois, have invented certain new and useful Improvements in Static Electrical Machines, of which the following is a specification.

This invention relates to certain improvements in static electric machines, and has for its object in part to provide for use in connection with such machines generally an improved and simplified pole-changing means capable of use for readily and conveniently changing the polarity of the terminals or electrodes of the machine and in part to provide a machine of this character of a simple and inexpensive nature and of a compact, strong, and improved construction which shall be adapted for self-excitation and which by reason of its improved structure shall afford an increased capacity for the generation of electricity.

The invention consists in certain novel features of the construction, combination, and arrangement of the several parts of the improved static electric machine whereby certain important advantages are attained and the machine is made simpler, cheaper, and of greater capacity and is otherwise better adapted and made more convenient for use, all as will be hereinafter fully set forth.

The novel features of the invention will be carefully defined in the claims.

In the accompanying drawings, which serve to illustrate my invention, Figure 1 is a front elevation showing a static electric machine embodying my improvements, portions of the frame or casing thereof being omitted for lack of space; and Fig. 2 is a side or end elevation of the same. Fig. 3 is a vertical section taken through the machine in the plane indicated by the line *a a* in Fig. 2 and showing certain details of the structure and arrangement of the moving plates or members thereof, together with the arrangement of the brush, collector, and equalizer arms. Fig. 4 is a sectional view somewhat similar to Fig. 3, but taken in the plane indicated by line *b b* in Fig. 2 and show-

ing in elevation one of the stationary plates or members of the machine for the illustration of those portions of the armature which are carried on the outer side of said plate or member. Fig. 5 is an enlarged detail view showing fragments of the stationary plates or members of the machine and showing certain details of the construction and arrangement of the armatures thereof, as will be hereinafter explained. Fig. 6 is an enlarged sectional view taken in the plane indicated by the line *e e* in Fig. 5 through the stationary and moving plates or members at one side or edge thereof for better illustration of the collecting devices. Fig. 7 is a view somewhat similar to Fig. 6, but taken in the plane indicated by line *d d* in Fig. 5 and showing certain features of the equalizing means to be hereinafter referred to. Fig. 8 is a view somewhat similar to Fig. 5, but showing the portions of the armature upon the inner or reverse sides of the stationary plates or members of the machine. Fig. 9 is an enlarged detail view taken through edge portions of the stationary plates or members of the machine in the plane indicated by line *e e* in Fig. 8 and showing certain details of the electrical connections between the two sides of the stationary plates or members. Fig. 10 is an enlarged sectional detail view showing means for affording a varying spark-gap for controlling the discharge at the electrodes of the machine. Fig. 11 is an enlarged sectional detail view showing certain features of the adjustable mounting of the pole-changing arms of the device. Fig. 12 is an enlarged sectional detail view taken through one of the brush-arms and the moving and stationary plates or members of the machine in the plane indicated by line *f f* in Fig. 5 and illustrating certain features of the construction and arrangement of the armature upon the stationary plate or member, as will be hereinafter explained.

As shown in the views, 1 indicates a part of the frame or casing of the machine, and 2 indicates a shaft horizontally extended therein and provided with a pulley 3, adapted to receive an endless belt or band, which is also extended, as shown at 4, around a pulley 5, upon

a driving-shaft provided in a well-known way with a crank for manual operation, by which means the shaft 2 may be turned in its bearings.

Upon the shaft 2 are held in any preferred way the moving members of the machine, herein shown as formed of circular glass disks or plates 6 6, and in the structure herein shown these moving members or plates 6 are arranged in pairs upon the shaft. There are four such pairs of the moving members or plates in the construction shown, although it will be evident that the number of pairs employed in a machine is immaterial to my invention, and the plates or members of each pair are spaced apart from each other, so as to receive between them the stationary members or plates 7 of the machine, which are also formed, as herein shown, of circular glass disks having central openings for the passage of shaft 2, the diameters of the plates or members 7 being larger than that of the moving plates or members 6, so that the peripheral edge portions of said stationary plates or members are caused to project beyond the edges of the moving plates in position to be conveniently engaged by devices for the support of said stationary plates.

The supporting devices for the stationary plates or members 7 comprise rods or bars 8 8, extended transversely across the edge portions of said plates or members, above and beneath the same, upon which rods or bars are adjustably held collars 9 9, between which the projecting edge portions of the plates or members 7 are held and whereby said plates or members are firmly supported in alinement with each other and with the moving plates or members. The arrangement of the stationary plates or members 7 7 is also such that their outer surfaces are held out of contact with the inner surfaces of the moving plates or members 6, and the inner adjacent surfaces of the stationary plates or members 7 7 are also spaced apart out of contact with each other.

Upon the moving plates or members 6 6, at front and rear of the machine—that is, on the respective front and rear surfaces of the first and last plates 6 6 on shaft 2—are carried buttons 10, suitably arranged to pass, when the plates or members are turned, beneath brushes 11, of which any preferred number may be employed at the opposite peripheral sides of the plates or members, said brushes 11 being, as shown in Figs. 7 and 12, provided with screw-threaded stems adjustably engaged with enlargements on the central portion of their supporting-arms, so that the brushes may be caused to approach more closely to or be moved farther away from said buttons 10, as will be readily understood. Lock-nuts are also provided on the screw-threaded stems of brushes 11 for holding them in adjusted position. When the brushes are moved toward the but-

tons, they will act to excite the plates or members 6, so as to give the machine the requisite initial charge; but after the machine has been charged it is evident that said brushes may be withdrawn from proximity to said buttons by merely turning their screw-threaded stems. One set of the brushes 11 at opposite peripheral sides of the members or plates of the machine are supported upon equalizing-arms 12 12, extended in alinement along the outer surfaces of the outer moving plates or members 6 6 on shaft 2, such arms or supports 12 12 at opposite sides of the machine being connected by portions 13, extended transversely across the peripheries of the series of plates or members and supported, as herein shown, by means of clips or projections 14 14, arranged in pairs and adapted to be passed upon opposite sides of the projecting peripheral portion of each stationary plate or member 7, the extremities of said clips or projections 14 being made rounded or circular and being cemented or otherwise securely held to said plates or members 7, so as to afford a firm and secure mounting for the equalizer-arms without requiring the employment of another form of insulated support. The equalizer-arms 12 12 at the back of the machine are also provided with an electrical connection 18, extended between them from the positive to the negative side of the machine, the central portion of said connection being bent or otherwise formed so as not to contact with the shaft 2 or other part of the machine and being properly insulated. At diametrically opposite sides of the machine are also arranged other brushes 11 11 at front and rear of the first and last plates or members 6 6, as seen in Figs. 2 and 12, and these brushes 11 are carried adjustably upon brush-arms 16 16, each extended inwardly from the periphery of the corresponding adjacent plate or member 6 to a suitable distance, the arms at front and rear of each side of the machine being alined and connected by portions 17, similar to the portions 13 of arms 12, and extended across the peripheries of the plates from front to rear of the machine and supported upon the peripheral portions of members or plates 7 7 by clips or projections 14, embracing and cemented or otherwise held to said projecting portions of the stationary plates or members to form a simple insulated support for the brush-arms.

Upon the portions 13 13 of the equalizer bars or arms 12 12 are carried auxiliary arms or bars 11^a 11^a, which are extended in alinement with the outer bars or arms 12 12 between each two adjacent series of plates or members included in the machine, there being, as seen in Fig. 2, three such arms or bars 11^a provided, and upon these auxiliary arms or bars 11^a and also upon the outer arms or bars 12 are provided combs 15 15, directed toward and in proximity to the adjacent sur-

faces of the corresponding movable plates or members 6 of the machine. Since the auxiliary arms or bars 11^a are located between two plates or members 6, it will be evident that each of said auxiliary bars or arms will be provided with a double comb, as clearly shown in Figs. 2 and 7. The equalizing devices above described form a connection between the two series of devices at opposite sides of the machine. At opposite sides of the machine there are also provided alined series of collecting devices (shown in detail in Fig. 6) and arranged between the brush-arms 16 and equalizer-arms 12, and these collecting devices comprise arms 27, extended radially from the peripheries of the plates for suitable distances inward therefrom and connected by supports 28, extended across the edges of the plates or members and supported therefrom by means of clips 14, engaged with the projecting peripheral portions of members, as above described. The arms 27 carry combs 29, directed toward the surfaces of the adjacent plates or members 6 and are located upon the front and rear sides of the machine, and between the plates or members of each series included in the machine there are arranged other similar collecting-arms 27^a, also provided with double combs 29, directed toward the corresponding members or plates 6 and connected electrically with the supports 28 in alinement with the outer arms 27.

At the front side of the machine each arm 27 has central connection with a conductor 30, which is extended forward and communicates with a receiver 31, supported on an insulated base 32 in a well-known way, and the receivers 31 31 at opposite sides of the machine are similarly formed and oppositely arranged and are provided with adjustably-mounted discharge-rods 33 33 of well-known form, adapted to be more or less closely approached one to the other for an entire or partial discharge of electricity between the receivers.

The armatures of the stationary plates or members 7 7 comprise segmental sheets or pieces 20 of paper or other suitable material, which are cemented or otherwise held upon the outer sides of the respective members or plates 7 of each pair, and each of the parts or pieces 20 has along one edge and alined with the corresponding collector-arms 27 27^a at that side of the machine a strip or piece 19 of positive conducting material, as metallic foil, held beneath said paper sheet or part 20, with a projecting serrated edge portion 21, free from plate 7 and adapted to extend toward the surface of the adjacent movable member or plate 6 to receive the discharge therefrom, as indicated in Figs. 4, 5, and 12 of the drawings. Each strip 19 has a curved portion directed centrally from it, which portion, as seen at 21^a, is held to the surface of the plate 7 beneath the paper strip or piece

20 and is extended around said plate to a point opposite to the brush-arm 16 at that side of the machine, at which point the said strip 21^a terminates in a circular enlargement alined with the brush 11 on said arm.

Opposite the brush-arm 16 the paper sheet or piece 20 is transversely slitted, as seen at 20^a in Figs. 4 and 12, and at said slitted part of the sheet or strip 20 and in alinement with the brush-arm is arranged beneath the said paper sheet or strip another piece or strip, 19^a, of metallic foil similar to the piece or strip 19, with a serrated edge portion 21 free from the plate and directed toward the adjacent movable member or plate 6 and with its central part in electrical communication with the circular enlargement at the end of strip 21^a which extends between and forms an electrical connection between the two strips or parts 19 and 19^a.

Each strip or piece 19^a has an outwardly-directed portion 22 extended across the peripheral projecting portion of the member 7 for electrical communication with the adjacent clip 14 and through said clip with the transversely-extended connection 17 between arms 16 16, and upon the inner surface of each stationary plate or member 7 there is extended from the clip 14 of part 17 of the brush-arms, as seen in Figs. 8 and 9, a similar conducting piece or strip 23 of metal foil, which is directed inward across that surface of the member 7 and has connection with one end of a curved strip or piece 24 of metal foil, which is held on the inner surface of member 7 in alinement with the paths of buttons 10 on plates 6 and is provided at its ends with circular enlargements 25, one of which corresponds in arrangement with the circular enlargement at the end of strip 21^a on the outer side of the plate 7 and the other of which is arranged in alinement with the strip 19 on the outer side of said plate or member 7 and also with the collecting-arms 27 at that side of the machine.

Over the metal foil 23 upon the inner surface of each plate or member 7 is cemented or otherwise held to said plate a segmental sheet or piece 26 of paper or similar negative material extended in alinement with the strip or piece 20 on the outer surface of the plate, but having an end portion extended beyond the termination of piece 20 at the collecting-arms 27 around the plate or member 7, with its extremity in alinement with the equalizer-arms 12 12.

By this arrangement it will be seen that portions of the armature are carried upon each side or surface of each stationary member or plate, an electrical connection being established across the edge of the plate between said two sides, so as to greatly increase the capacity of the machine for the generation of electricity. The connection between the portions of the armature upon opposite

surfaces of each plate or member 7 is also such as to connect each side of each plate or member 7 of the respective pairs with the corresponding brush-support 17, so that the said supports 17 form electrical connections between the several plates or members 7 7 comprised in the machine. The arrangement of the armature parts upon the plates or members 7 7 is also such as to entirely prevent the liability of sparking across from the electro-positive armature parts to the shaft 2 of the machine or to the equalizer-arms 12 12, so that the loss occasioned by such sparking, which would greatly lessen the capacity of the machine for electrical generation and would also result in quick deterioration, is altogether prevented.

The improved machine constructed as above described is adapted for self-excitation, the arrangement and structure of the several parts permitting the brushes 11 to be withdrawn from proximity to the buttons 10 without lessening the efficiency of the machine after it has been initially charged, and in connection with the machine thus constructed I have shown my improved pole-changing means, which comprises collars 34, held to turn on conductors 30 and having pins or studs 34^a, on which are engageable tubular nipples 35 on arms or rods 37, which have insulated handles and are capable of adjustment for effecting a change of polarity in certain terminals or electrodes of the machine. The nipples 35 are provided with slits 36 in their sides, so as to permit them to be readily engaged on the pins or studs 34^a, on which the arms or rods 37 are thus adapted for a certain degree of pivotal movement around the axes of the pins or studs, and since the collars 34 turn on conductors 30 it will also be seen that the arms or rods 37 of the pole-changing means may be swung pivotally upon said conductors 30—as, for example, from the position seen in full lines in Fig. 11 to that seen in dotted lines therein.

In connection with the arms or rods 37 37 at opposite sides of the machine and connected with the terminal conductors 30 30 thereof the pole-changing means comprises a series of contacts 38, corresponding with each arm or bar 37, each series of contacts 38 being supported upon a bar or piece 39 of insulating material held on the frame, the arrangement herein shown being such that one of the insulating-supports 39 is above and the other below the plane of the shaft 2 of the machine. The contacts 38 of each series are spaced apart at suitable intervals along the length of the support 39 at distances which may be regulated, as desired, but which is adapted to be bridged by the arc produced by the machine, and each arm or bar 37 is adapted for contact when in one position—as, for example, that seen in full lines in Fig. 11—with one series of contacts 38 and when in its

other position, as seen in dotted lines in said figure, is adapted for engagement with the contacts of the other series. By pivotal movement of each arm or rod 37 upon the stud or pin 34^a as a center it will also be evident that said arm or bar may be adjusted along the length of the support 39 to engage either one of the series of contacts 38 thereon. Each insulated support 39 is also provided at its end with a socket adapted to receive the end of a conductor, which may be extended therefrom for use in connection with a vacuum-tube or otherwise, and one of the contacts 38 on each support has a stem 42 extended into said socket in position for engagement with such terminal when the same is inserted in the socket, as indicated at 41 in Fig. 10, so that when the arms or bars 37 are engaged with said contact 38, as indicated in full lines in Fig. 10, the charge will be transmitted from conductor 30 through arm or rod 37 to contact 38 and thence to the conductor 41. In a like manner it will be seen that when the arms or rods are adjusted along the supports 39 into engagement with successive contacts 38 thereon, as indicated in dotted lines at *x* and *x'* in said figure, a gap or gaps will be produced in the path of the discharge, which will be bridged by arcs in such a way as to lessen or increase the intensity of the discharge through the conductors 41. In Fig. 1 I have shown one of the arms or rods 37 raised and engaged with a contact 38 of the upper series and the other arm or rod lowered and engaged with a contact of the lower series, and in this way a certain polarity will be afforded at each of the contacts 38, which may be changed at will by reversing the arrangement of the arms or rods 37 37. By this construction it will be seen that the polarity of the upper and lower contacts 38 may be changed at will, so that it is not required to determine the polarity of the contacts by other testing appliances, as is commonly done prior to connecting up the machine for use. By engaging the arms or bars 37 with each other it will also be seen that the machine may be completely discharged, and it will also be seen that by engaging said arms or bars 37 37 with different contacts 38 in the same series a partial discharge of the machine may be had independent of the employment of the discharge-rods 33 33.

The improved machine constructed as above described is of an extremely simple and inexpensive nature and is especially well adapted for use owing to the increased capacity afforded by the utilization of the two side surfaces of each plate or member 7 for the generation of electricity. The construction is also extremely advantageous, for the reason that the peculiar means employed for supporting the brushes and collecting-arms upon the stationary members permits of altogether dispensing with additional insulated supports

therefrom, whereby the machine is greatly simplified and cheapened.

The construction of the improved machine with the peculiar formation and arrangement of the armatures also renders the device self-exciting after the initial charge, so that after the machine has been charged the brushes may be thrown out of operation without affecting the operation of the machine in generating electricity. It will also be obvious from the above description that the improved machine is capable of considerable modification without material departure from the principles and spirit of the invention, and for this reason I do not wish to be understood as limiting myself to the precise form and arrangement of the several parts of the device herein set forth in carrying out my invention in practice.

Having thus described my invention, what I claim, and desire to secure by Letters Patent, is—

1. A static electrical machine comprising two disk-like members mounted for relative movement and having parallel surfaces provided at opposite peripheral sides with devices adapted for reciprocal operation for the generation and collection of electricity and equalizing means comprising parts supported upon opposite peripheral sides of one member and having a connection extended between its points of support.

2. A static electrical machine comprising two series of members, those of one series being movable relative to those of the other and the members of one series each having an armature part on each surface, the armature parts on the respective opposite surfaces each comprising an electropositive part and the said electropositive parts on opposite sides of each member being in electrical communication.

3. A static electrical machine comprising two series of members movable relatively one to the other, the members of one series being arranged in pairs between those of the other and each having upon opposite surfaces armature parts which are in electrical communication.

4. A static electrical machine comprising two series of members movable relatively one to the other, armature parts on opposite surfaces of each member of one series and an electrical connection between the armature parts on opposite surfaces of the members of said series and extended across the edge portions of the respective members of that series.

5. A static electrical machine comprising two series of members movable relatively one to the other, the members of one series being arranged in pairs between those of the other series and each having upon opposite surfaces armature parts, electrical connections extended across the edges of the members of said series between the armature parts on opposite

surfaces thereof, a bar extended across the edges of the members with parts in electrical communication with said connections and brushes on said bar in proximity to the surfaces of the members of the other series.

6. A static electrical machine comprising a member having on opposite surfaces armature parts each comprising an electropositive part and an electronegative part extended over said electropositive part, the electropositive parts having connection across the edge of said member.

7. In a static electrical machine the combination of two plates one of which is provided with electrically-connected armature parts on opposite surfaces, the armature part on one surface of said plate comprising an electropositive part held on said plate with a portion extended away from the surface of such plate and in proximity to the adjacent surface of the other plate.

8. In a static electrical machine, the combination of two plates one of which is provided with an armature part comprising an electropositive part on one surface of said plate with a portion extended away from the surface of such plate and in proximity to the other plate.

9. In a static electrical machine, the combination of two plates one of which has an armature part comprising an electropositive part on one surface of said plate with a serrated portion extended in proximity to the other plate.

10. In a static electrical machine, the combination of two plates one of which is provided with an armature comprising an electropositive part on one surface of said plate and extended away from the surface of such plate and in proximity to the adjacent surface of the other plate, a brush on the opposite surface of the last-named plate and having electrical connection with said electropositive armature part and a device on said last-named plate for coaction with the brush for initially charging the machine.

11. A pole-changing means for static electrical machines comprising adjustable parts electrically connected with conductors of a static electrical machine and contacts adapted to form terminals of such machine and with which each of said adjustable parts is adapted for electrical communication.

12. A pole-changing means for static electrical machines comprising adjustable parts electrically connected with conductors of a static electrical machine and two series of spaced contacts, one contact of each series being adapted to form a terminal of such machine and the said adjustable parts being each adapted for electrical communication with each contact of each series.

13. A pole-changing means for static electrical machines comprising conductors connected with generating means, parts each supported on and electrically connected with one

of said conductors for pivotal movement in two directions at angles to each other and two series of spaced contacts each of which comprises a contact adapted to form a terminal
 5 of such machine, each of the pivotal parts being adapted, when swung in one direction, to be approached to one or the other of the respective series of contacts and when swung
 10 in another direction to be successively approached to the several contacts in one or the other of said series.

14. In a static electrical machine, the combination of generating devices, terminal conductors, one of which is adapted for electrical
 15 communication with the generating devices, a series of spaced contacts adjacent to the other terminal conductor and an electrical connection extended from the generating devices and
 20 comprising a part adjustable for electrical communication with one or another contact in said series.

15. In a static electrical machine, the combination of generating devices, an insulated support having a socket, terminal conductors,
 25 one of which is electrically connected to the generating devices and the other of which is carried on said support and has a part extended in said socket for electrical communication
 30 with a conductor inserted therein, a series of spaced contacts on the insulated support for electrical communication with the terminal conductor thereon and an electrical connection extended from the generating devices and comprising a part adjustable for electrical

communication with one or another contact in
 35 said series.

16. In a static electrical machine, the combination of two plates one of which has an armature comprising a plurality of parts held
 40 on one surface of the plate and each provided with a portion extended away from the surface of such plate and in proximity to the other plate and an electrical connection extended from one part to the other across the
 45 surface of the plate to which said parts are secured.

17. A static electrical machine comprising two relatively movable members one of which has at opposite peripheral sides armature parts
 50 on opposite surfaces, the armature parts on one surface of said member having extended portions which are out of alinement with the armature parts on the opposite surface of said member, exciting and collecting devices
 55 alined with the armature parts on one surface of said member and equalizing means comprising connected parts arranged at opposite peripheral sides of the member and alined with the extended portions of the armature part on the opposite surface of said
 60 member.

Signed at Chicago, Illinois, this 28th day of
 January, 1904.

CHARLES F. BIRTMAN.

Witnesses:

CHAS. C. TILLMAN,
 A. GUSTAFSON.

Journal of the History of Medicine and Allied Sciences, Vol. 72, No. 2, pp. 166–192
 doi: 10.1093/jhmas/jrx001
 Advance Access Publication: March 16, 2017

OXFORD

The Medical Battery in The United States (1870–1920): Electrotherapy at Home and in the Clinic

ANNA WEXLER

ABSTRACT

This paper focuses on the history of a portable shock-producing electrotherapeutic device known as the medical battery (1870–1920), which provided both direct and alternating current and was thought to cure a wide variety of ailments. The product occupied a unique space at the nexus of medicine, consumerism and quackery: it was simultaneously considered a legitimate device by medical professionals who practiced electrotherapeutics, yet identical versions were sold directly to consumers, often via newspaper advertisements and with cure-all marketing language. Indeed, as I show in this paper, the line between what was considered a medical device and a consumer product was often blurred. Even though medical textbooks and journals never mentioned (much less promoted) the home use of electricity, every reputable electrotherapy instrument manufacturer sold a “family battery” for patients to use on themselves at home. While a handful of physicians spoke out against the use of electricity by the laity—as they felt it undermined the image of electrotherapy as a skilled medical procedure—existing evidence suggests that many physicians were likely recommending the home use of medical electricity to their patients. Taken together, this paper shows how the professional ideals of electrotherapeutics were not always aligned with physicians’ actual practices.

KEYWORDS: electrotherapy, electrical medicine, medical battery, quackery, faradic Batteries

INTRODUCTION

In 1892, A. D. Rockwell, a New York-based physician and one of the leaders in the field of electrical medicine, spoke at the American Electrotherapeutic Association about the threats to the credibility of the field, or as he put it, “hindrance[s] to the right

Corresponding Author: Anna Wexler, Email: annaw@mit.edu, Phone: 917.640.8722, Mailing Address: Anna Wexler, Department of Science, Technology and Society, ES1-070, Massachusetts Institute of Technology, 77 Massachusetts Ave, Cambridge MA 02139

© The Author 2017. Published by Oxford University Press. All rights reserved.
 For Permissions, please email: journals.permissions@oup.com

• 166

Downloaded from <https://academic.oup.com/jhmas/article/72/2/166/3073509> by guest on 03 May 2023

appreciation and the right use of electricity.”¹ Although Rockwell noted that both “self-confessed charlatans” and dubious medical colleagues presented challenges for electrotherapeutics, he felt that more pernicious threats were posed by two other groups: “members of the regular profession who freely use electricity” presumably without sufficient training, and the general public, “who either with or without advice make use of this agent as commonly and as confidently as they take their morning bath or daily friction.”²

Expounding upon the public’s use of electrotherapeutics, Rockwell lamented that “anyone can buy a battery of some sort, for the market is glutted with machines of the most inexpensive and worthless construction.”³ Indeed, Rockwell was correct: in the late nineteenth and early twentieth century, the advent of mail-order catalogues meant that a plethora of electrotherapy products—such as electric belts, socks, and hairbrushes—were widely available for direct purchase by consumers; many of these products were marketed with the promise of curing everything from cancer to headaches.⁴ But it was not these products that were the target of Rockwell’s frustration; rather, his ire was directed toward an item he refers to as a “battery.”

The battery—more commonly known as a “medical battery”—was a simple shock-producing device, consisting of a battery and an iron core encased in a wooden box (Figure 1).⁵ Most medical batteries were approximately the size of a shoebox, though “pocket” medical batteries could be as small as a paperback book and high-end medical batteries with extra features could be as large as a carry-on suitcase. They usually provided both direct and alternating current and were used to administer low levels of electrical stimulation to the body to treat a variety of diseases. For physicians interested in electrotherapeutics, the medical battery was often the entry-level device offered in an electromedical instrument catalogue. But medical batteries were also sold directly to the public by electric novelty and supply companies, individual instrument makers, and even companies that manufactured medical instruments for physicians. For Rockwell, the public’s use of the medical battery undermined the notion of electricity as a serious scientific and medical technique that required years of training and expertise.

In some ways, the issues raised by the medical battery were not unique to electrotherapeutics: the increase in direct-to-consumer health products in the nineteenth century (sometimes referred to as the rise of the medical marketplace) challenged physicians’ authority over healthcare. Historians Anne Digby, Takahiro Ueyama,

1 A. D. Rockwell, “The Uses and Abuses of Electricity in Medicine,” *Journal of the American Medical Association* 20, no. 3 (January 21, 1893), 72.

2 Ibid.

3 Ibid., 73.

4 Carolyn Thomas de la Peña, *The Body Electric: How Strange Machines Built the Modern American* (New York: New York University Press, 2003), 105–121.

5 Dean P. Currier, *Guide to Electrotherapy Instruments and History of Their American Makers*, (West Conshohocken, PA: Infinity Publishing, 2013). This book, which is a 500-page guide for antique collectors, is the most comprehensive work to-date on the medical battery.

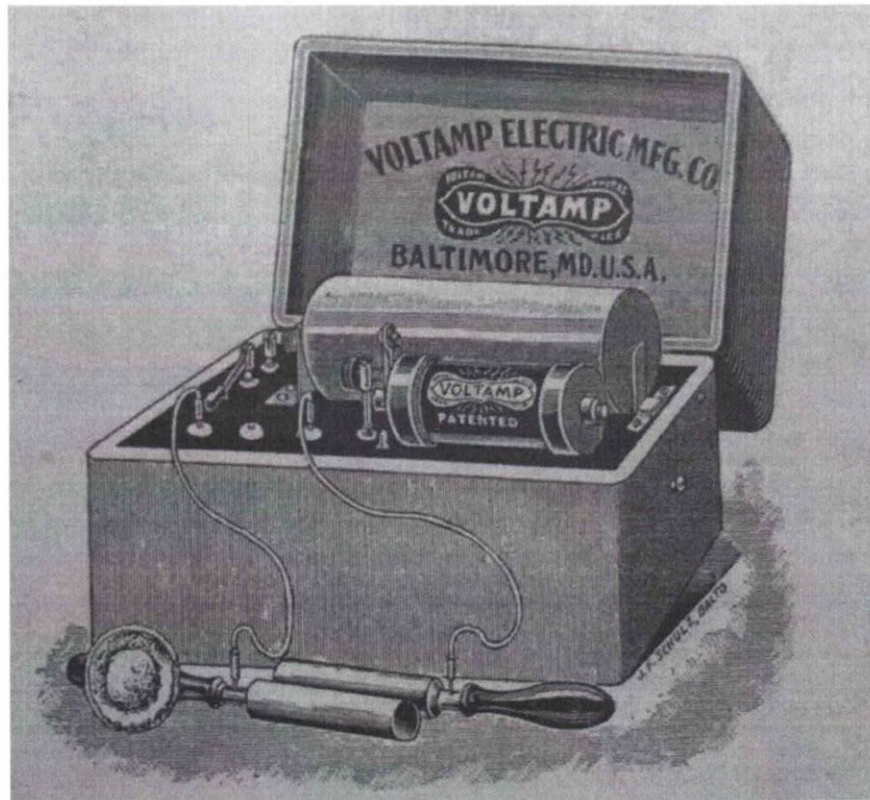

Fig. 1. Medical battery No. 4 from the Voltamp Electric Manufacturing Co, as advertised in the company's 1904 catalogue. Bakken Library Collection.

Joseph Gabriel and others have chronicled how physicians in Britain and the United States (US) attempted to position the medical profession in opposition to entrepreneurialism.⁶ Any doctor who advertised his or her practices, held a patent on a medicine, or who was involved in profit making was liable to be labeled as a quack.⁷ Another defining feature of quackery was the sale (or recommendation) of so-called patent medicines⁸ whose ingredients were kept secret by their manufacturers. When the American Medical Association (AMA) was founded in 1847, it adopted a Code of Ethics that framed an “ethical” medical profession in opposition to the practices of

6 Anne Digby, *Making a Medical Living: Doctors and Patients in the English Market for Medicine, 1720-1911* (Cambridge University Press, 2002); Takahiro Ueyama, *Health in the Marketplace: Professionalism, Therapeutic Desires, and Medical Commodification in Late-Victorian London* (Society for the Promotion of Science and Scholarship, 2010); and Joseph M. Gabriel, *Medical Monopoly: Intellectual Property Rights and the Origins of the Modern Pharmaceutical Industry* (University of Chicago Press, 2014).

7 Digby, *Making a Medical Living*, 61; Gabriel, *Medical Monopoly*, 57-63.

8 Despite the name, such medicines were rarely patented. See Gabriel, *Medical Monopoly*, 17-18.

quackery; any “concealment” regarding medicines was considered “inconsistent with beneficence and professional liberty.”⁹

But whereas one of the defining features of quackery with regard to medicines was secrecy of ingredients, the same criterion did not hold true for electrotherapeutic devices: anyone who purchased a consumer electrotherapy device could open up the product and see how it worked, and magazines and books offered step-by-step instructions for constructing a medical battery.¹⁰ For electrical medicine, then, overt commercialism (i.e., public advertising and sales) and exaggerated claims were other indicators of quackery.¹¹ Another marker was the sale of electrotherapy products that were not used by the medical profession: no regular physician would imagine writing about electric socks or brushes in a medical journal—indeed, it was unclear whether the devices even provided an electric current—and such products were written off as nostrums.¹²

But the medical battery occupied a more complex space at the nexus of medicine, consumerism, and quackery. Because electrical treatment via the medical battery was considered a legitimate electrotherapeutic technique—as evidenced by numerous mentions of it in books and articles written by the physicians who practiced electrotherapeutics—the product itself, even when sold directly to consumers, could not be dismissed as quackery. While there were indeed those who sold the medical battery directly to consumers with cure-all claims—and such companies were therefore likely to be labeled as quacks—there were many retailers selling medical batteries to consumers *without* cure-all claims and with minimal advertising. Thus in many ways the sale of the medical battery to the laity (and its subsequent use in home settings) represented a separate issue than that of quackery; indeed, in Rockwell’s speech, he distinguished the threats presented by charlatans from those posed by the public’s use of the medical battery.

Yet Rockwell was one of the very few to speak out about the issue; on the whole there was no outcry among physicians regarding the use of electricity at home. In fact, every reputable electrotherapy instrument manufacturer sold at least one model of the

9 American Medical Association, *Code of Ethics of the American Medical Association, Adopted May 1847* (Philadelphia: T.K. and P.G. Collins, printers, 1848), 16 (Chapter 2, Article 1, Section 4). See also Robert Baker, “The Historical Context of the American Medical Association’s 1847 Code of Ethics,” in *The Codification of Medical Morality*, ed. Robert Baker, *Philosophy and Medicine*, Volume 49 (Springer Netherlands, 1995).

10 “Amateur Mechanics,” *Popular Mechanics* 11, no. 10 (1909), 36; Selimo Romeo Bottone, *Electrical Instrument Making for Amateurs, a Practical Handbook* (London, Whittaker & Co.; New York, D. Van Nostrand, 1888); Norman Hugh Schneider, *Induction Coils: How to Make, Use, and Repair Them Including Ruhmkorff . . .*, 2nd ed. (Spon & Chamberlain, 1901); and Frederick Charles Allsop, *Induction Coils and Coil-Making; a Treatise on the Construction and Working of Shock, Medical and Spark Coils* (New York: E. & F N. Spon; Spon & Chamberlain, 1894).

11 As Dr. Samuel Monell, a founder and chief instructor at the New York School of Special Electro-Therapeutics, put it: “no medical writer who has won recognition as a competent authority in the field of electro-therapeutics has ever *over-stated* the value of electric currents in medicine. . . Experienced medical men in this branch of practice seek ultra-conservatism, and shun exaggeration as science itself shuns quackery.” Samuel Howard Monell, *High Frequency Electric Currents in Medicine and Dentistry* (New York: W. R. Jenkins Company, 1910), 128-129.

12 *Ibid.*, 129-130.

medical battery for “family” use, and physicians could recommend or even purchase such products on behalf of their patients. That the “family battery” remained in the catalogues of reputable electrotherapy instrument manufacturers in the United States for approximately fifty years (between 1870 and 1920) suggests that there was a significant demand for the product for this period of time. Thus, while physicians did not publicly promote or even write about the home use of electricity, I will suggest here that they were likely more involved in the practice than they appeared in print.

This paper explores how the medical battery blurred the lines between medicine, consumerism, and quackery in the United States in the late nineteenth and early twentieth century. In many ways it follows the work of Lori Loeb and Peter Bartrip, who have shown that the presumed gulf between the medical profession on the one hand, and quackery (and consumerism) on the other, was often not as large as regular physicians professed it to be. Loeb, for example, has argued that many British physicians were quietly involved in recommending patent medicines to their patients, despite the medical profession’s official stance against them.¹³ She has also shown how many individuals who were derided as “quacks” by the medical profession were in fact upstanding citizens who embraced the rising commodification of healthcare.¹⁴ Along similar lines, Bartrip has demonstrated how the *British Medical Journal* (BMJ) financially benefitted from running advertisements for patent medicines even as it was actively campaigning against them.¹⁵ Thus, as Bartrip notes, “ethical rhetoric was not always in step with marketplace reality.”¹⁶ In a similar vein, this paper highlights discrepancies between the professional ideals of electrotherapeutics and physicians’ actual practices.

While much scholarship has focused on irregular medical practitioners and consumer electrotherapy products that were dismissed by the regular profession as quackery, this paper centers on the sale and use of a direct-to-consumer electrotherapeutic product, the medical battery, that was viewed as legitimate by physicians practicing electrical medicine in the US in the late nineteenth and early twentieth century. It should be emphasized, however, that electrotherapy was not uniformly accepted by the medical profession; physicians who practiced electrical medicine were liable to find themselves facing “sarcastic remarks and sneers” from their medical colleagues.¹⁷ Yet

13 Lori Loeb, “Doctors and Patent Medicines in Modern Britain: Professionalism and Consumerism,” *Albion* 33, no. 3 (October 2001): 404–25.

14 Lori Loeb, “George Fulford and Victorian Patent Medicine Men: Quack Mercenaries or Smilesian Entrepreneurs?” *Canadian Bulletin of Medical History/Bulletin canadien d’histoire de la médecine* 16, no. 1 (1999): 125–45.

15 Peter Bartrip, “Secret Remedies, Medical Ethics, and the Finances of the British Medical Journal,” in *The Codification of Medical Morality*, ed. Robert Baker, Philosophy and Medicine, Volume 49 (Springer Netherlands, 1995).

16 *Ibid.*, 192.

17 William Harvey King, “Some of the Causes Which Retard the More Rapid Progress of Electro-Therapeutics,” *Journal of Electrotherapeutics* 10 (1892): 66. See also Lisa Rosner, “The Professional Context of Electrotherapeutics,” *Journal of the History of Medicine and Allied Sciences* 43, no. 1 (January 1, 1988), 68.

the practice did achieve a certain measure of professional acceptance: by the 1890s electrotherapy had become part of the curriculum in some medical schools,¹⁸ and the proceedings of the annual conference of the American Electrotherapeutic Association (AEA) were published in the pages of the esteemed *Journal of the American Medical Association* (JAMA). Thus, when I refer to the medical profession and regular physicians in the context of electrotherapeutics, I am referring to those medical professionals—usually possessing medical degrees from established institutions—who both practiced electrotherapy and would have been welcome at American Medical Association (AMA) meetings.

Despite the apparent historical popularity of the medical battery, little scholarship has been devoted to its manufacture and use, particularly in the United States. Indeed, the term “medical battery” in historical literature is perhaps most strongly associated with the case of C. B. Harness, whose London-based Medical Battery Company was successfully sued for fraud in 1892 by a customer who had purchased an electric belt.¹⁹ Here, however, I use the term “medical battery” as it was commonly used in the U.S. in the late nineteenth and early twentieth century, in reference to simple electrotherapy apparatuses designed to provide low levels of current for electric treatment. As sales records from companies and reports from consumers are largely nonexistent, I have relied upon trade catalogues and newspaper advertisements, as well as surviving medical batteries, to reveal how different actors marketed and utilized the medical battery in multiple ways.

I begin by providing background on the rise of consumer electrotherapy products in the United States, situating the medical battery in the context of other consumer electrotherapy products. Next, I explore the medical battery market, characterizing how the wide variety of consumer- and physician-oriented companies differentially marketed the device. After considering the “family battery” and the (lack of) debate over the acceptability of self-treatment with electricity, I discuss the decline of the medical battery in the 1910s and note its contemporary revival in antique markets.

18 Timothy Kneeland and Carol Warren, *Pushbutton Psychiatry: A Cultural History of Electric Shock Therapy in America* (Walnut Creek, CA: Left Coast Press, 2008), 29. Indeed, in 1892, W. F. Osbourne, the manager of the eastern office of the *Western Electrician*, reflected on the rise of electrotherapy in the mainstream medical profession: “Twenty years ago work in this line was considered a disreputable thing for a regular physician, and the subject was never mentioned in any of the medical colleges or journals. To-day all the medical colleges deal with it more or less, and you can seldom find an issue of a medical journal that does not contain something in reference to it.” W. F. Osbourne, “Correspondence: New York Notes,” *Western Electrician*, Vol. 11, (17 September 1892), 153.

19 For discussions of the case, see Lori Loeb, “Consumerism and Commercial Electrotherapy: The Medical Battery Company in Nineteenth-Century London,” *Journal of Victorian Culture*, 4, 2 (1999); and Takahiro Ueyama, “Capital, Profession and Medical Technology: The Electro-Therapeutic Institutes and the Royal College of Physicians, 1888–1922,” *Medical History* 41, no. 02 (April 1997): 150–81, doi:10.1017/S0025727300062360.

THE RISE OF CONSUMER ELECTROTHERAPY IN THE UNITED STATES

In the first half of the nineteenth century, electricity in the United States was characterized by performance and spectacle.²⁰ According to historians, “the electrification of the human body became a source of public entertainment.”²¹ Entertainers would travel from city to city, performing one-night shows that combined short lectures about electricity with sensational displays of sparks and shocks. By the late nineteenth century, electricity was no longer merely a novelty relegated to traveling showmen; it began to creep into homes and the fabric of daily life.

When the town of Wabash, Indiana set up the state’s first public lighting display in 1880, approximately 10,000 visitors travelled to witness the spectacle.²² According to the local newspaper, “People stood overwhelmed with awe, as if in the presence of the supernatural.”²³

But electricity brought more than just lighting: at the turn of the century, the advent of elevators, trolleys, and telephones rapidly revolutionized public infrastructure, transportation, and communication. Inside the home, electricity brought major changes to domestic routines. Homes connected to the electrical grid could make use of newly invented household appliances such as washing machines, hot water heaters, vacuum cleaners, and electric stoves.²⁴ However, the adoption of domestic electricity was gradual; though electricity appeared in public places and well-off homes in the 1890s, most houses were not wired until the late 1920s.²⁵

Electricity also dramatically transformed methods of production: automatic machines running on newly invented electric motors and sensors increasingly replaced skilled labor. Given the constant availability of power (and electric light), factories no longer had to shut down at night and could produce goods twenty-four hours a day. Mass production methods allowed companies to manufacture a huge variety of consumer goods at relatively cheap prices.²⁶ In the 1880s and 1890s, mail order companies like

20 Stanley Finger and Marco Piccolino, *The Shocking History of Electric Fishes: From Ancient Epochs to the Birth of Modern Neurophysiology* (Oxford: Oxford University Press, 2011), 167; Paola Bertucci, “Therapeutic Attractions: Early Applications of Electricity to the Art of Healing,” in *Brain, Mind and Medicine: Essays in Eighteenth-Century Neuroscience*, ed. Harry Whitaker, C. U. M. Smith, and Stanley Finger (Springer US, 2007), 271-272.

21 Kneeland and Warren, *Pushbutton Psychiatry*, 10-11.

22 David Nye, *Electrifying America: Social Meanings of a New Technology* (Cambridge: MIT Press, 1990), 3.

23 *Wabash Plain Dealer*, 1880, as quoted in Nye, *Electrifying America*, 3.

24 Nye, *Electrifying America*, 18-20.

25 Ben Wattenberg, *Statistical History of the United States* (New York: Basic Books, 1977), as quoted in Nye, *Electrifying America*, 16, and footnote 50, 395.

26 Nye, *Electrifying America*, 13-14. For more on the effects of mass production on big business, see Alfred D. Chandler, *The Visible Hand* (Harvard University Press, 1993) and David Hounshell, *From the American System to Mass Production, 1800-1932: The Development of Manufacturing Technology in the United States* (Baltimore: Johns Hopkins University Press, 1985). For works on the rise of the consumer society (albeit in Britain) see, e.g., Neil McKendrick, John Brewer, and J. H. Plumb, *The Birth of a Consumer Society: Commercialization of Eighteenth Century England* (London: HarperCollins Publishers Ltd, 1984); and John Benson, *The Rise of Consumer Society in Britain, 1880-1980* (London: Longman Group United Kingdom, 1994).

Montgomery Ward & Company printed massive catalogues that offered tens of thousands of products, such as clothing and accessories, household appliances, toys and games, machine tools, building materials, home decor, furniture, and farming equipment.²⁷ Moreover, one did not need to live in a city to purchase such products. The rapid expansion of railroads in the 1850s and 1860s meant that these items were available even to those living in remote, rural areas.²⁸ According to one historian, with the advent of mail order catalogues, “it needn’t really matter whether one lived in city or country, for the good life could be purchased by mail wherever one made one’s home.”²⁹

One class of products offered for sale in mail order catalogues (and advertised in newspapers and magazines) were so-called patent medicines, which were often marketed as “cure-alls.” The 1902 Sears catalog offered products such as obesity powders (“a boon to fat people”), “sure cures” for the “tobacco habit” and opium habits, wonder heart cures, a “Mexican Headache and Neuralgia Cure,” and Siberian catarrh snuff.³⁰ One page of the catalogue was devoted entirely to pills: blood pills, nerve and brain pills, “wonderful little liver pills,” cathartic pills, and even “Dr. Worden’s Female Pills,” for curing every kind of “female trouble.”³¹ Tonics, tinctures, syrups, bitters, wines and teas were advertised for the remedy of everything from consumption to rheumatism to scrofula.³²

Against this mid-to-late nineteenth century backdrop—with the gradual rise of electrification and the surge in availability of cheap consumer goods—electrical devices for medical purposes entered the consumer market. Device manufacturers capitalized on both the excitement about electricity and the lack of knowledge on the part of the public: “Brewster’s Medicated Electricity,” for example, purportedly consisted of a battery in a glass bottle, “combined with vegetable compounds” that generated “a vapor which is a safe, convenient, and speedy method of obtaining relief from Nervous Headache, Catarrh, Hay Fever, Neuralgia.”³³

Electric combs and hairbrushes were sold to cure baldness, nervous headaches, and other diseases; an “electric flesh brush” was marketed as a cure-all.³⁴ Electric insoles were touted as a treatment for rheumatism, gout, cold feet, and all kinds of pains and aches.³⁵ There was an electric garter for women that would “subdue all cramps and

27 William Cronon, *Nature’s Metropolis: Chicago and the Great West* (New York: W. W. Norton & Company, 1991), 336-337.

28 *Ibid.*, 68.

29 *Ibid.*, 338.

30 Catalogue No. 112, Sears, Roebuck & Co, 1902, 440, digital archive accessed on December 14, 2015, <https://archive.org/stream/catalogueno11200sear#page/438/mode/2up>

31 *Ibid.*, 440.

32 *Ibid.*, 441-451.

33 “Brewster’s Medicated Electricity,” undated pamphlet, Bakken Ephemera Collection, The Bakken Muesum, Minneapolis, Minnesota, hereafter BEC.

34 “Improved Electro-Magnetic Hair Brush and Comb,” New York and London Electric Association, undated, and “Riley’s Electric Comb Battery,” 1899, BEC.

35 “Illustrated Catalogue of the Leading Electric Novelties and Appliances,” Ohio Electric Works, 5, undated, and “Dr. Bridgeman’s Electro-Magnetic Belts, Corsets, Supporters, Braces, Insoles, and Appliances,” *Harper’s Magazine*, ca. 1891, BEC.

stiffness of joints” and electric corsets to “ward off disease.”³⁶ Various companies sold ladies’ electric “spinal appliances” and unisex “lung appliances.”³⁷ Voltaic-electric porous plasters were marketed as remedies for dyspepsia, bilious colic, cramps and pains. “Electric-magnetic” rings and pendants,³⁸ often consisting of nothing more than alternating metals—supposedly activated when in direct contact with skin—were sold to a willing public, as were electro-massage machines.³⁹

Electric belts (Figure 2) were one of the most popular consumer electrotherapeutic products.⁴⁰ The J. L. Pulvermacher Company advertised its belts as being “self-applicable, for the cure of nervous and chronic diseases without medicine.”⁴¹ Other companies, too, marketed their belts as cure-alls, though some belts, particularly those marketed to men, insinuated that the products were effective at treating sexual dysfunction (many belts came with a “suspensory” attachment). Low-end electric belts sold for a few dollars, but deluxe models, which provided more current, could cost as much as seventy-five dollars (nearly \$2,000 in 2016 dollars).⁴² More common was the price range of ten to twenty dollars.⁴³

Although electric belts were briefly used by a handful of regular physicians in the US in the late 1870s and early 1880s,⁴⁴ by the 1890s they had come to symbolize quackery, and regular physicians and electromedical device manufacturers frequently cautioned against them. For example, in *The Electro-Therapeutic Guide*, Dr. Homer Clark Bennett wrote that the “ordinary so-called electric belt is a fake pure and simple, made to sell,

36 Dr. Scott’s Electric Corset, ca. 1879, periodical unknown, reprinted in Robert K. Waits, *The Medical Electricians: George A. Scott and His Victorian Cohorts in Quackery* (Sunnyvale, California: CreateSpace Independent Publishing Platform, 2013), 253.

37 “German Electric Belts and Appliances,” (German Electrical Agency, 1893); and “Catalogue of Owen Electric Belt and Appliances,” (Dr. A. Owen Electric Belt and Appliance Company, 1892) Bakken Library Collection, The Bakken Museum, Minneapolis, Minnesota, hereafter BLC.

38 Dr. Bridgman’s Electro-Magnetic Ring, *Scribner’s*, December 1892, reprinted in Waits, *Medical Electricians*, 288; also see advertisement for Electro-Chemical Ring (Toledo, Ohio), undated, BEC. For pendants, see, e.g., advertisement for the London Galvanic Generator, *Harper’s Weekly*, October 30, 1880, reprinted and discussed in *Medical Electricians*, 65.

39 See, e.g., “Dr. John Butler’s Electro-Massage Machine (or Electric Manipulator) for Curing Disease at Home,” ca. 1889, BLC.

40 For more on electric belts, see de la Peña, *Body Electric*, 108-121; Waits, *Medical Electricians*; Kneeland and Warren, *Pushbutton Psychiatry*, 39-40; Carolyn Thomas de la Peña, “Designing the Electric Body: Sexuality, Masculinity and the Electric Belt in America, 1880-1920,” *Journal of Design History* (2001), 275-289.

41 “Electricity - Nature’s Chief Restorer,” Pulvermacher Galvanic Co, 1882, BEC.

42 Dollar values estimated according to the “Consumer Price Index (Estimate) 1800-,” Federal Reserve Bank of Minneapolis, accessed January 8, 2016, <https://www.minneapolisfed.org/community/teaching-aids/cpi-calculator-information/consumer-price-index-1800>. The \$75 belt was Dr. McLaughlin’s Invigorator, Bakken Artifact Collection.

43 Catalogue No. 112, Sears, Roebuck & Co, 1902, 471-472, accessed January 8, 2016, <https://archive.org/stream/catalogueno11200sear#page/470/mode/2up>

44 For example, in *A System of Physiologic Therapeutics: Electrotherapy*, Dr. George W. Jacoby discussed the belt’s possible usefulness, though he was careful to distinguish the McIntosh belt he recommend from “the majority of belts” which had “merely a suggestive value.” George W. Jacoby, *A System of Physiologic Therapeutics: Electrotherapy*, ed. Solomon Solis Cohen (Philadelphia: P. Blakiston’s Son & Co, 1901), 146-147.

OUR \$12.00 HEIDELBERG BELT.

\$12.00 IS OUR PRICE for this powerful 60-gauge genuine Heidelberg Belt. Electric Belts equal to one \$12.00 12-cell, 60-gauge current Heidelberg, are being sold by widely advertised dealers at \$40.00 and upwards, and yet all of these high priced Electric Belts lack the peculiar strengthening curative properties of the Heidelberg Adjusting Current Belt. The Heidelberg Belt sends the weak diseased parts at once. It produces an invigorating current of magnetic and galvanic electricity, wonderful cure for neural or vital weakness, nervous debility or impotence, stops almost immediately the unusual waste or loss of vitality. The \$12.00 Belt has just the power required for cases that are not too aggravated and will help not only men or women suffering from any organic disease no matter of how long standing.

OUR SPECIAL \$12.00 HEIDELBERG BELT is one of the simplest electric belts made. It is a no-complicated sort to get out of order. It is easily adjusted, perfect in its most comfortable electric field modes. Self-adjusting, non-conducting, fully worn easily put on or off, perfectly washable made of high grade materials throughout, will last forever. The \$12.00 Belt is a result of years of scientific study and experiment. It is a belt that contains the latest features, comfort and health giving points not to be found in any other make.

GOOD FOR EITHER SEX. The \$12.00 Belt can be worn without the temporary absence of menstruation and is invaluable for all cases of female weakness. The electric current is a great strengthener. In fact the only treatment required by women suffering from weakness peculiar to their sex. Every member of the family can be benefited by the use of a Genuine Heidelberg Belt. We have instances where one of our Heidelberg Belts has been worn successively by five or six members of one family, all of whom experienced good results. Moreover, the belt used and be worn constantly; three or four hours' wear at a time is sufficient.

IF YOU HAVE ANY DOUBTS AS TO THE EFFICACY OF OUR HEIDELBERG ELECTRIC BELTS, let us send you our complete book describing them and explaining the electric treatment in detail. Our Free Electric Belt Catalogue contains pamphlets letters from people who have worn the Heidelberg Electric Belt and realized wonderful benefits from its use. Perhaps among these letters you will find a case similar to your own and may be induced to give the belt a trial, and thus secure the relief you have heretofore looked for in vain.



DON'T FAIL
to send
for our
FREE
Electric Belt Catalogue.
No. 4275012 Our
60-gauge Electric
Belt. Price **\$12.00**

Fig. 2. A \$12 electric belt in the 1902 Sears, Roebuck & Co catalogue.

and then to disintegrate.”⁴⁵ The Jerome Kidder Manufacturing Company, a respected electromedical instrument manufacturer, devoted the first page of its catalogue to distinguishing itself from the “obvious humbugs and swindles,” warning readers to “beware of all the so-called electric pads, belts, bands, brushes, armadillos and garments, as they are made to deceive the public, and not for any Electrical effect.”⁴⁶ Even the editors of the magazine *Electricity* wrote that “electric belts, electric hair-brushes, electric headache cures, electric light baths etc., etc., are unqualified frauds upon the public. . . . They are frauds, or else the therapeutical and electrical authorities are all wrong.”⁴⁷

THE MEDICAL BATTERY (1870-1920)

In contrast to electric belts and brushes, which were shunned by the medical profession, the medical battery was regularly used by physicians who practiced electrotherapy. Early versions of the medical battery were hand-constructed by individual instrument makers in the 1850s and 1860s, largely in Boston and New York.⁴⁸ Unlike the colorful electric belts, the medical battery—which came encased in a variety of nondescript oak, mahogany, walnut, and cherry wood boxes—was rather understated in appearance. Inside the wooden box, a battery was connected to a wire that was wrapped around an iron core, and a second wire—not connected to the battery or the first wire—was also wrapped around the iron core. When the battery was turned on, a direct current was produced in the first wire, thereby magnetizing the iron core. A variety of methods were used to pulse the direct current—causing rapid changes in the magnetic

45 Dr. Homer Clark Bennett, *The Electro-Therapeutic Guide: Or, A Thousand Questions Asked and Answered*, 8th ed. (Lima, Ohio: Literary Department of the National College of Electro-therapeutics, 1907), 66.
 46 *Illustrated and Descriptive Catalogue of their Superior Electro-Medical Apparatus* (New York: Jerome Kidder Mfg Co, ca. 1890). BLC.
 47 “The Electrical Exhibit at the Fair Disgraced by Their Admission,” *Electricity*, 5 (16 August 1893), 52. See Waits, *Medical Electricians*, 207-208, for further discussion.
 48 Currier, *Guide to Electrotherapy Instruments*, 30-63.

flux of the iron core, thereby inducing an alternating current in the second wire.⁴⁹ Most medical batteries—which it should be emphasized, refer not just to the physical battery itself but the entire apparatus—provided the primary, direct current (which was referred to as “galvanic” current and came in pulses), the secondary, alternating current (often referred to as “faradic” current), or a combination of both. Even though most batteries provided both direct and alternating current, they were sometimes referred to as “faradic batteries.”

The medical literature published at the time referenced two main techniques of applying current. In general faradization, one electrode was placed beneath the patient’s feet (although sometimes both the patients’ feet and the electrode were submerged in water) while the second electrode was rubbed over the body, either by the patient or physician. Central galvanization was a variation in which the stable electrode was placed above the stomach instead of beneath the feet.⁵⁰ General faradization or galvanization was thought to target the body as a whole, and was often recommended as a treatment when an illness was systemic in nature. By contrast, local faradization or galvanization was advised when a pain or illness was situated in a particular part of the body. Current was generally not recommended for more than ten to twenty minutes for general applications, and several minutes for local applications. Treatment was prescribed several times a week, or even daily. Overall, electrical treatments were deeply rooted in somaticism—that is, current was applied to the part of the body that was ailing—and it was believed that electricity could “loosen” any unhealthy blockages and promote circulation.⁵¹

A number of developments catapulted the medical battery into popularity in the 1880s and 1890s. First, methods of mass production allowed for the product to be cheaply produced en masse instead of being hand-built by instrument makers. Second, the advent of mail order catalogues facilitated the sale of medical batteries to consumers and physicians living in both urban and rural areas. Third, technological innovations helped make the medical battery a more appealing product: up until the 1890s, most medical batteries were of the wet-cell variety, which required the user to add a conductive fluid. By the early 1890s, medical battery manufacturers began to use dry cells that consisted of a paste rather than a wet solution—making the product more attractive, as there was less of a possibility of spilling or corrosion.⁵²

Although the medical battery came to prominence concomitantly with electric belts and other consumer electrotherapy products, it seems to have dwarfed them in at least some measures of popularity. While sales figures are largely nonexistent, in the course of my research on trade catalogues at the Bakken Museum in Minneapolis, Minnesota, digitized versions of the magazine *Electrical World* and *American Electrician*, and secondary literature on electrotherapeutics, I counted roughly two dozen electric belt

49 These automatic current interrupters were known as rheotomes; see *ibid.*, 20-21.

50 A.D. Rockwell, *The Medical and Surgical Uses of Electricity*. (New York: William Wood and Company, 1896), 236-237.

51 John Greenway, “Nervous Disease’ and Electric Medicine.” In *Pseudo-Science and Society in Nineteenth-Century America*, edited by Arthur Wrobel, (Lexington, KY: University Press of Kentucky, 1987), 52-55.

52 Rosner, “The Professional Context of Electrotherapeutics,” 77.

manufacturers in the US in the late nineteenth and early twentieth century.⁵³ By comparison, using the same measures, I counted over 150 companies that sold their own brand of medical battery in the United States between 1870 and 1920, as well as over a hundred additional retailers that distributed these brands. Although these measures are skewed towards museum collecting and journal digitization practices—and absent sales records it is impossible to reach definitive conclusions—they suggest a greater demand for the medical battery than for the electric belt. Indeed, this is not surprising, as the medical battery effectively had two markets—physicians and consumers—whereas electric belts were purchased almost exclusively by consumers.

MEDICAL BATTERIES FOR PHYSICIANS

From 1870 to 1920, there were approximately a dozen companies that sold their own brand of high-end medical batteries for physicians, primarily located in New York, Chicago, Philadelphia, and Baltimore. These companies sold electromedical products through secondary retailers for surgical and medical supplies, as well as directly to physicians via illustrated catalogues.⁵⁴ The catalogues became a source of reference for physicians, as they often contained a brief history of the use of electricity in medicine, an overview of its present uses, and a glossary of terms.⁵⁵ From the catalogues, physicians could learn about the different tools available for treatment, and details such as which electrode was most appropriate for use on which part of the body.⁵⁶

The names of prominent electromedical instrument manufacturers appeared frequently in medical journals and in electrotherapy guides written by regular physicians. For example, in *Practical Electro-Therapeutics* (1888), Dr. William Hutchinson noted that the “best American instruments” were made by companies such as Flemming and McIntosh.⁵⁷ In *Clinical Therapeutics* (1885), Dr. C. L. Dana wrote that “good faradic batteries are now made by a great many firms,” such as Kidder, the Galvano-Faradic company, Waite & Bartlett, Stammers, Flemming, and McIntosh.⁵⁸ Physicians also

53 This figure is my own conservative estimate, based on both primary sources (Bakken Library, Ephemera, and Artifact Collections; American Medical Association’s Historical Health Fraud Archives) and digital archival research, as well as secondary sources (de la Peña, *Body Electric*, 108–120; Waits, *Medical Electricians*, 203–21; Dean P. Currier, “Components of the Electrical Belt,” Quackatorium, accessed December 26, 2015, <https://web.archive.org/web/20030819021239/http://www.radiantslab.com/quackmed/deanbeltco mp.html>); and Currier, *Guide to Electrotherapy Instruments*.

54 “General catalogue - Noyes Brothers & Cutler, Importers and wholesaler dealers in drugs” (St Paul: Noyes Brothers & Cutler, 1891), BLC.

55 See, e.g., *Illustrated Catalogue of McIntosh Combined Galvanic and Faradic Battery*. (McIntosh Galvanic and Faradic Battery Co., 1881), BLC; also see Currier, *Guide to Electrotherapy Instruments*, 213.

56 For more on how physicians (albeit in Britain) utilized medical trade catalogues in the late nineteenth and early twentieth century, see Claire L. Jones, “(Re-)Reading Medical Trade Catalogs: The Uses of Professional Advertising in British Medical Practice, 1870–1914,” *Bulletin of the History of Medicine* 86, no. 3 (2012): 361–93, doi:10.1353/bhm.2012.0056.

57 See e.g., William Francis Hutchinson, *Practical Electro-Therapeutics* (Philadelphia: Records, McMullin & Co, 1888), 26.

58 Dujardin-Beaumetz, *Clinical Therapeutics*, trans. E. P. Hurd (Detroit: G.S. Davis, 1885), 46. Note that this is an English translation of a French work, with certain parts replaced to suit American physicians. See p. 42, noting that the ensuing section is written by Dr. C. L. Dana.

recommended specific parts made by the companies, for example, by mentioning that they liked a certain brand of neck electrode⁵⁹ or voltmeter.⁶⁰

The medical battery was just one of the items offered for sale in electrotherapeutic catalogues. The Waite and Bartlett catalogue from 1895, for example, featured a handful of static electricity machines, as well as several “wall cabinet” batteries (Figure 3) for physician’s offices, which cost \$200 to \$260 (approximately \$5,000 to \$7,000 in 2016 dollars) and could be ordered in oak or mahogany.⁶¹ The catalogue offered eight different medical batteries, ranging in price from ten dollars to sixty-six dollars. In addition, Waite and Bartlett sold approximately one hundred different electrode attachments for their devices, including many that were specially shaped for different parts of the body (e.g., nasal, ear, rectal, and intra-uterine electrodes).

Prominent electromedical instrument manufacturers such as Waite and Bartlett interacted closely with regular physicians as well as with professional organizations such as the American Electrotherapeutic Association (AEA).⁶² They frequently attended the AEA’s annual conferences, where they set up booths to display their latest wares.⁶³ In turn, the AEA created committees to test and review electrotherapeutic devices (such as medical batteries) and their components. Prior to each “test,” companies with credibility in the eyes of the committees were invited to submit their products for review. For example, at the AEA’s seventh annual meeting in 1897, the Committee on Meters reported on its recent test of several voltmeters (from Weston, Edison, Vetter, Chloride of Silver, Kidder, McIntosh, and Keystone).⁶⁴ Members from each company traveled to New York to be physically present for the test—presumably placing enough value on the outcome to make the trip.⁶⁵

The relationship between the major electromedical instrument manufacturers and regular physicians was characterized by mutual dependence, similar to the symbiotic relationships Claire Jones has described between physicians and medical instrument manufacturers in the British context in the late nineteenth century.⁶⁶ Manufacturers relied on physicians for sales, and would sometimes appeal to the AEA, for example, by

59 Hutchinson, *Practical Electro-Therapeutics*, 197.

60 George W. Jacoby, *A System of Physiologic Therapeutics: Electrotherapy*, ed. Solomon Solis Cohen (Philadelphia: P. Blakiston’s Son & Co, 1901), 162.

61 “Illustrated Price List, Electro-Medical and Electro-Surgical Instruments,” (New York: Waite & Bartlett Mfg Co, 1895-1896). <http://archive.org/details/illustratedprice00wait>.

62 The American Electrotherapeutic Association (AEA) was created in 1891 with the aim of separating regular uses of electricity from that of quackery. As later AEA president Dr. Charles Rea Dickson put it, “[i]t was felt, and felt strongly, that electricity had been left too long to the charlatan, the incompetent, and the unscrupulous.” “Eighth Annual Meeting of the American Electro-Therapeutic Association,” *Electrical Engineer* 26, no. 54 (October 6, 1898): 347.

63 For the record of presenters at the fourth annual meeting of the AEA, see Samuel Howard Monell, “An Electrical Exhibit,” *The Medical Times and Register*, October 13, 1894, 237.

64 American Electrotherapeutic Association, *Transactions of the American Electro-Therapeutic Association*, 10-27. <http://babel.hathitrust.org/cgi/pt?id=mdp.39015062239382>

65 Ibid.

66 Claire L. Jones, *The Medical Trade Catalogue in Britain, 1870-1914* (Routledge, 2015).

requesting that it select a standardized measurement for a particular component.⁶⁷ In turn, physicians depended on the manufacturers to make high quality products and sometimes called on manufacturers to incorporate specific design features. Though I found no records of physicians being compensated for recommending specific brands, there are occasional mentions of physicians being sent components by manufacturers, presumably without cost.⁶⁸

To a large extent, physician-oriented companies adhered to the ethics of the medical profession; they did not advertise their wares in popular outlets, relying instead on illustrated catalogues that were distributed to the medical profession. Descriptions of the medical battery and other electromedical products in these catalogues were dry, and focused on the technical aspects of the product: dimensions, weight, number of battery cells, and price. Whereas advertisements for consumer electrotherapy products were often accompanied by an illustration of an individual using the device, illustrations in medical device catalogues consisted of simple depictions of the products themselves.

MEDICAL BATTERIES FOR CONSUMERS

In contrast to electromedical instrument manufacturers, consumer-oriented companies frequently advertised their medical batteries in general interest magazines like *McBrides's* and *Popular Mechanics* as well as in local newspapers. The majority of consumer-oriented medical battery retailers were electrical supply and novelty companies that sold medical batteries alongside products such as motors, fans, burglar alarms, bells, electric neckties, and telegraph supplies. Unlike electromedical instrument manufacturers, who sold medical batteries with names like "No. 4 Office Battery" or the "No. 2 Battery," consumer-oriented companies often gave their batteries enticing names, such as "Home Comfort," "Solace," or "Relief."⁶⁹ Consumers could buy these medical batteries in their local general stores and drugstores, and many were available through mail order catalogues. The names of companies who sold medical batteries primarily to consumers do not appear in the pages of electrotherapeutic texts or records of the AEA's annual meetings.

The medical batteries sold by consumer-oriented companies were often similar in price, or slightly cheaper, than the low-end models sold by electromedical instrument manufacturers. Many fell in the range of four to eight dollars, although top-of-the-line models could sell for as much as twelve dollars,⁷⁰ and rock-bottom medical induction coils—such as the Dunn-Martin Electric Company's "shocko"—sold for just a dollar. Some electrical companies, like the Manhattan Electrical Supply Co, sold a variety of models of medical batteries for many years, whereas for others, the medical battery was a short-lived endeavor en route to a larger business in automobile or telephone

67 American Electrotherapeutic Association, *Transactions of the American Electro-Therapeutic Association* (Toronto: William Briggs, Wesley Buildings, 1897), 28. <http://babel.hathitrust.org/cgi/pt?id=mdp.39015062239382>

68 Hutchinson, *Practical Electro-Therapeutics*, 201.

69 "Faradic Hints: The Faradic Current in the Treatment of Disease," Voltamp Electric Mfg Co. (Baltimore, 1904), 18, BLC.

70 Currier, *Guide to Electrotherapy Instruments*, 458.

**CURE YOURSELF BY
ELECTRICITY**

IF YOU SUFFER
from Rheumatism, Neuralgia, Constipation, Nervousness, Headache, Stomach Trouble or any other disease, I will send you a battery on ten days' trial.
MY VALUABLE NEW BOOK FREE
to all who write. Explains how my wonderful inexpensive batteries cure you in your own home. Tells how Electricity treats disease by striking the root. How it removes the cause, then cures the disease to stay cured. How it builds up and nourishes wasted tissue. It tells how I send a battery without a cent in advance and allow ten days free trial. Write today for this valuable book, I will send it free.



DETROIT MEDICAL BATTERY CO., E. C. Harkness, Gen'l Manager
578 Majestic Building - - - Detroit, Michigan

Fig. 4. Advertisement for the Detroit Medical Battery in the May 1907 issue of *Popular Mechanics*.

products. The *Electrical World*, an electricity-related trade magazine, kept tabs on commercial activity in the electrical industry, reporting on the formations and closures of companies, product innovations, patents, and electrical fairs and exhibitions.

Outside of electrical supply and novelty companies, another class of consumer-oriented companies—often those who also sold electric belts and garments—sold medical batteries that were frequently billed as “cure-alls.”⁷¹ For example, in an advertisement in 1907 in *Popular Mechanics*, the Detroit Medical Battery Company claimed that its medical battery cured “Rheumatism, Neuralgia, Constipation, Nervousness, Headache, Stomach Trouble or any other disease” (Figure 4).⁷² The price range of these medical batteries was similar to those sold by electric companies (approximately one to twelve dollars). Free trials and money-back guarantees were just some of the gimmicks used to hook potential customers.

Some consumer-oriented companies explicitly positioned themselves in opposition to the medical profession, portraying the medical battery as an effective alternative to a

71 “Electricity, when applied by an Automatic Medical Battery, will cure rheumatism,” The Automatic Battery Co., *McBride's Magazine* 42, (1888), 54.

72 This same advertisement for Detroit Medical Battery ran for several years (1906-1908) in *Popular Mechanics*. For sample see “Cure Yourself by Electricity,” *Popular Mechanics* 9, no. 5 (1907), 591.

pricey, time-consuming visit to the doctor. A catalogue from the German Electric Agency, which briefly sold a brand of P. G. Williams batteries, stated that it was their “aim to place in the hands of the public a battery with which they can cure themselves with little expense and without loss of time.”⁷³ The Manhattan Electrical Supply Co. even incorporated an anti-medical theme into the name of one its batteries, the “Anti-Doc Medical Apparatus.” The company advertised the product heavily for at least seven years, noting that it cost “less than one application [of electricity] by your doctor.”⁷⁴

Although companies who sold medical batteries with cure-all claims and money-back guarantees might be dismissed as quacks, the medical battery itself, which was considered a legitimate therapeutic tool, seemed largely immune to such criticism. Rather than assailing the legitimacy of consumer medical batteries or their underlying therapeutic potential, medical practitioners criticized their *quality*. Dr. William Hutchinson wrote that the “numerous small induction machines in the market” were “valuable only as toys,” and cautioned physicians to “let such playthings alone.”⁷⁵ In the speech quoted at the start of this paper, A. D. Rockwell criticized the plethora of batteries as being “of the most inexpensive and worthless construction.”⁷⁶ Thus, in contrast to electric belts and brushes, which were considered to be quackery, the medical battery sold to consumers was instead portrayed as a cheap imitation of a legitimate product.

BLURRED BOUNDARIES

It was not always easy to distinguish between a consumer and physician battery: the products were nearly identical, and some companies marketed *both* to physicians and consumers. For example, Herman C. Tafel, of Louisville, Kentucky, sold electrical instruments to consumers as well as medical and surgical supplies to physicians.⁷⁷ Some companies, such as the B. B. Bliss Electric Co., sold a consumer medical battery, yet advertised in medical journals.⁷⁸ Even the Jerome Kidder Manufacturing Company, one of the most reputable manufacturers of high-quality batteries for the medical profession, occasionally took out advertisements in consumer publications stating that its product “conquered” disease.⁷⁹

That some companies marketed medical batteries simultaneously to physicians and consumers is somewhat surprising, as it was far more common, both in the US and in

73 “German Electric Belts and Appliances,” (New York: German Electrical Agency, ca. 1901), 25. BLC.

74 “Anti-Doc Medical Apparatus,” Manhattan Electrical Supply Co, *The Railroad Telegrapher* 24 Part 2 (1907), 2154.

75 Hutchinson, *Practical Electro-Therapeutics*, 16-17.

76 A. D. Rockwell, “The Uses and Abuses of Electricity in Medicine,” *Journal of the American Medical Association* 20, no. 3 (January 21, 1893), 73.

77 James M. Edmonson, *American Surgical Instruments: The History of Their Manufacture and a Directory of Instrument Makers to 1900* (San Francisco: Norman Publishing, 1997), 193.

78 “Doctor’s Favorite: The Best Dry Cell Battery in the World,” B. B. Bliss Elec. Co., *New Charlotte Medical Journal* 5 (1894), 98.

79 Dr. Jerome Kidder’s Electro-Medical Apparatuses, Jerome Kidder Manufacturing Co, *Electrical World* 2 (December 1, 1883), 258.

Britain, for companies to align themselves with a single market.⁸⁰ Although in the late nineteenth and early twentieth century some British companies published catalogues of health products that were marketed both to physicians and consumers, the catalogues did not contain electromedical devices; instead they featured “sundries” like hot water bottles, belts, and hernia trusses, and were for the most part not marketed to treat disease.⁸¹ In contrast, American companies who sold medical batteries to both physicians and consumers marketed their products with the implication, if not outright specification, of treating disease. The medical battery, then, occupied a distinctive space on the medical marketplace—while other electrotherapy products were sold only to physicians (e.g., wall cabinet batteries) or consumers (e.g., electric belts and brushes), the medical battery flourished for nearly fifty years in both the home and clinic.

In some ways, physicians who dabbled in electrotherapy became the beneficiaries of rising consumerism, as many of the medical batteries sold to consumers were essentially the same as those sold to physicians—only cheaper. For example, the German Electric Agency, a well-known electric belt manufacturer, claimed that its line of P. G. Williams medical batteries were “first-class machines in every respect, equal to machines that formerly sold for \$25 or \$30. We offer them to the public at prices ranging from \$3.50 to \$12.”⁸² Such models would have been appealing to physicians who were interested in trying electrotherapeutics without making a sizable financial investment.

Although it is impossible to determine the extent to which physicians purchased consumer medical batteries, the criticism that emerged from some prominent physicians suggests that the practice was not uncommon. For example, Dr. Samuel Monell, a founder and chief instructor at the New York School of Special Electro-Therapeutics,⁸³ denounced the “honest but untaught” physicians who purchased such batteries and used them in “ignorance,” for they were erroneously “attributing to mere toy devices the efficiency of costly scientific apparatus.”⁸⁴ Then, when the medical battery failed to work, physicians (and patients) blamed electricity “instead of the inferior apparatus.”⁸⁵ Similarly, Dr. William Hutchinson felt that cheap medical batteries, and the untrained physicians who used them, were one of main reasons why electrotherapeutics had not achieved widespread acceptance amongst the medical profession at-large.⁸⁶ Both physicians attempted to draw boundaries between physician and consumer batteries by emphasizing the expense of a “real” medical battery; Hutchinson stated that a basic start-up outfit (comprised of several thirty or thirty-five dollar batteries with

80 Claire L. Jones, *The Medical Trade Catalogue*, 54–57.

81 According to historian Claire Jones, “a small number of catalogues produced in Britain between 1870 and 1914 promoted medical sundries as aids to health aimed at both doctors and their patients. Few of these catalogues contained products to directly treat an ailment or cure a medical condition and no surgical or dental instruments or electro-medical apparatus were included in the product range.” Claire L. Jones, *The Medical Trade Catalogue*, 54.

82 “German Electric Belts and Appliances,” (New York: German Electrical Agency, ca. 1901), 25. BLC.

83 Samuel Howard Monell, *High Frequency Electric Currents*, title page.

84 *Ibid.*, 129.

85 *Ibid.*, 130.

86 Hutchinson, *Practical Electro-Therapeutics*, 17.

accessories) would cost approximately a hundred dollars,⁸⁷ while Monell wrote that a “competent faradic apparatus costs from \$50 upwards.”⁸⁸

Interestingly, every major electromedical instrument manufacturer had at least one battery for families in their catalogues. The product was almost always the only item in the entire catalogue that was directed at non-physicians. For example, among the eight batteries listed in the 1895 Waite and Bartlett catalogue, there were six “faradic” medical batteries for physician use, and two ten-dollar medical batteries—the cheapest in the catalogue—one billed simply as a “Family Battery” and the other as an “Electro-Magnetic Machine – for Family Use.”⁸⁹ Another major medical manufacturer, McIntosh, carried a similar “family faradic battery” (Figure 5);⁹⁰ other manufacturers referred to their version of the same type of product as a “home battery” or a “domestic battery.”⁹¹ Although the name varied, the “family battery” was usually the entry-level medical battery in most catalogues. Electromedical instrument manufacturers emphasized its affordability, quality (“made of good material”), and ease of use (“It is so simple a child can use it”).⁹²

The line between what was considered a physicians’ battery and a family battery was often murky. Sometimes the same model of medical battery was marketed *both* for physician and family use, such as Jerome Kidder’s No. 4 “Office and Family Apparatus”⁹³ or Flemming’s “No. 1 Faradic Battery,” which as the company noted was “intended chiefly for the use of physicians” but for “private family use it will be found especially valuable”⁹⁴ due to its simplicity and convenience. In other cases, the intended primary market for a medical battery shifted over time: Jerome Kidder’s No. 3 battery was marketed for both office and family use in 1871, but the same product, in the company’s 1874 and 1875 catalogues, was marketed just for physician use.⁹⁵ Electromedical instrument manufacturers also attempted to set their family batteries apart from the

87 Ibid., 197.

88 Samuel Howard Monell, *High Frequency Electric Currents*, 131.

89 “Illustrated Price List, Electro-Medical and Electro-Surgical Instruments,” (New York: Waite & Bartlett Mfg Co, 1895-1896), 18, 46. Accessed June 2, 2016, <http://archive.org/details/illustratedprice00wait>.

90 “Illustrated Catalogue of McIntosh Combined Galvanic and Faradic Battery,” (McIntosh Galvanic and Faradic Battery Co., 1881), 19. BLC.

91 For example, the Victor Electric Company sold a “Home Faradic Battery” and G. P. Pilling had a domestic faradic battery. “Catalogue no. 28 of Victor Electro-Surgical Apparatus,” (Chicago, IL: Victor Electric Company, ca. 1905), 49; “Complete Guide for Domestic Treatment by Electricity” (Philadelphia: G.P. Pilling & Son, 1905), 30-31. BLC.

92 “Illustrated Catalogue of McIntosh Combined Galvanic and Faradic Battery,” (McIntosh Galvanic and Faradic Battery Co., 1881), 19; “A New Family Battery - The Lord Baltimore” by Chloride of Silver Dry Cell Battery Co., in “General catalogue: Noyes Brothers & Cutler,” (St Paul: Noyes Brothers & Cutler, 1891), 438. BLC.

93 “Electro-Allotropo-Physiology: Uses of Different Qualities of Electricity to Cure Disease” (New York: Dr. Kidder’s Electrical Establishment, 1875). BLC.

94 “Illustrated Catalogue of Flemming’s Electro-Therapeutic Apparatus, Electro-Surgical Apparatus, Electrodes, Etc,” (Philadelphia: Press of Wm. H. Bartholomew, 1886), 23.

95 “Dr. Jerome Kidder’s Highest Premium, Vitalizing, Genuine Six and Nine Current Electro-Medical Apparatuses,” (New York: Jerome Kidder’s Electrical Manufactory, 1871), 7; “Electro-Allotropo-Physiology: Uses of Different Qualities of Electricity to Cure Disease” (New York: Jerome Kidder, 1874 and 1875). BLC.



Fig. 5. A “family battery” from the McIntosh Illustrated Catalogue, ca. 1885. Bakken Library Collection.

cheaper consumer batteries on the market. For example, McIntosh, a reputable electro-medical instrument manufacturer, described its family battery as “not merely a toy, such as is offered to the public, but one made of good material in a substantial manner,”⁹⁶ and the Victor Electric Company stated that its family battery was “far superior to the small cheap outfits so extensively advertising to the laity, and that are nothing more or less than ‘shocking’ machines.”⁹⁷

To acquire a family battery from an electromedical instrument manufacturer, patients could purchase the medical battery directly via catalogues or physicians could order medical batteries on their patient’s behalf. As electromedical instrument manufacturers sometimes offered a discount of around ten to fifteen percent to medical professionals, it is possible that physicians made a small commission on sales to their patients. However, I did not come across any indication in the medical or popular literature of physicians profiting from the sales of family batteries to patients. Furthermore, in the numerous works of Monell, who was the most outspoken critic of the family battery (and of physicians who recommended it), no mention is made of physicians financially benefitting from sales of the family battery.

96 “Illustrated Catalogue of McIntosh Combined Galvanic and Faradic Battery,” (McIntosh Galvanic and Faradic Battery Co., 1881), 19. BLC.

97 “Catalogue no. 28 of Victor Electro-Surgical Apparatus,” (Chicago, IL: Victor Electric Company, ca. 1905), 49.

administered only by experienced professionals? The widespread accessibility of the medical battery to the public—both via consumer outlets and electromedical instrument manufacturers—represented a tacit endorsement of the former characterization; it advanced the image of the medical battery as a *product* to be purchased and used, rather than electrotherapy as a *technique* to be administered by experienced medical professionals. Indeed, Monell fought on behalf of the latter characterization, writing that “in a true sense there can be no family battery; there can only be a proper use of electrical remedies when trained physicians administer them.”¹⁰⁸

But Monell, who was the most vocal critic of the home use of the electricity, seemed to have been waging a solitary and ultimately rather fruitless battle against the family battery. On the whole, physicians were silent on the topic; indeed, there is a striking absence of debate or discussion on the topic. While physicians were easily united in their fight against quackery, there was no comparable public outcry against the home use of electricity. Given the cozy relationship that many physicians enjoyed with electromedical instrument manufacturers, it is telling that no pressure was exerted on these companies to halt sales of the family battery, and the product continued to be sold by electromedical instrument manufacturers into the 1910s. Thus, taken together, existing evidence—both from the long life of the family battery and criticism that emerged from physicians like Monell—suggests that while the self-administration of electricity was not written about in medical books or journals, it was a practice that physicians likely recommended to their patients.

DECLINE OF THE MEDICAL BATTERY

By 1905, mentions of the medical battery in medical journals and textbooks had largely been replaced by references to newer electrotherapeutic technologies, such as sinusoidal-wave producing devices (which produced a smoother type of alternating current via an electric motor)¹⁰⁹ and high frequency devices. Although some electromedical instrument manufacturers continued to carry older galvanic and faradic models of their medical batteries, by the 1910s, as on-the-grid electricity made its way into the home, using a battery—instead of plugging into the wall—seemed like an outdated approach, and the medical battery began to slowly fade from medical catalogues.

The disappearance of the medical battery also tracked that of electrotherapeutics as a whole. During World War I and after, medical schools removed electrotherapy courses from their curriculums, and journals began to reject articles about electrical medicine.¹¹⁰ The *American Journal of Electrotherapeutics*, which had become the *Journal of Advanced Therapeutics* in 1902, changed its name to the *American Journal of Electrotherapeutics and Radiology* in 1916, reflecting interest in the applications of the newly discovered Roentgen rays.¹¹¹ In 1927, the journal changed its name once again,

108 Monell, *Electricity in Health and Disease*, 81.

109 Currier, *Guide to Electrotherapy Instruments*, 485.

110 Kneeland and Warren, *Pushbutton Psychiatry*, 38.

111 See record for “The Journal of Advanced Therapeutics,” Hathitrust Digital Library records, <http://catalog.hathitrust.org/Record/000638395>

to *Physical Therapeutics*.¹¹² Membership in the AEA declined to a new low by 1915, and by 1929 the organization been subsumed under the American Physical Therapy Association.¹¹³ While some physicians continued to practice electrotherapy, by the 1920s the practice had become increasingly marginalized. Physicians and electromedical instrument manufacturers whose names had once appeared in the pages of the *Journal of Electrotherapeutics* were liable to be investigated by the AMA for quackery in the 1920s.¹¹⁴ In Europe, too, interest in electrotherapy had declined; according to one scholar, the field was largely “defunct” in Britain by the early 1920s.¹¹⁵

Some historians have attributed the decline of electrotherapeutics to the concurrent shift to psychology and psychoanalysis, which located “nervous” diseases in the mind rather than the body itself.¹¹⁶ Electrical treatments, which were based on restoring depleted bodily energy, did not mesh with new theories of disease that centered on the subconscious mind.¹¹⁷ Indeed, as Sigmund Freud’s theories began to grow in popularity, the field of psychology staked its claim on mental diseases, and somatic diseases were incorporated under “physical therapy.” Other historians, however, have suggested that the decline is partly attributable to the fact that a mechanism of action for electrical treatment was never clearly elucidated—and that the results of electrical treatment were often mixed.¹¹⁸

112 See record for “Physical Therapeutics,” Hathitrust Digital Library records, <http://catalog.hathitrust.org/Record/000638388>

113 Kneeland and Warren, *Pushbutton Psychiatry*, 37–38.

114 McIntosh, once a well-respected electromedical instrument manufacturer, became the target of an AMA investigation in 1924 for employing an individual who allegedly faked a medical degree. AMA Health Fraud Archives, American Medical Association Archives, Chicago, Illinois, Box 0229-23, hereafter AMA Health Fraud Archives. The AMA also maintained a small file on the Jerome Kidder Manufacturing Company, another electro-medical instrument manufacturer that was once considered one of the most reputable in the industry. By 1915 the company was selling electric “ozone” devices with claims that the AMA felt were false. AMA Health Fraud Archives, Box 0231-20. In addition, Homer Clark Bennett, a former contributor to the *Journal of Electrotherapeutics*, was investigated by the AMA for selling a mail-order training course in electrotherapeutics. AMA Health Fraud Archives, Box 0232-05.

115 James Stark, in his work on Overbeck’s Rejuvenator’s, notes that: “John Senior has examined the context of neurology, concluding that by the start of the 1920s electrotherapy was largely defunct as an amateur, marginal practice.” See James F. Stark, “Recharge My Exhausted Batteries’: Overbeck’s Rejuvenator, Patenting, and Public Medical Consumers, 1924–37,” *Medical History* 58, no. 4 (October 2014): 500. Stark references Senior’s unpublished thesis: John Senior, ‘Rationalising Electrotherapy in Neurology, 1860–1920’ (unpublished PhD thesis: Oxford University, 1994).

116 Kneeland and Warren, *Pushbutton Psychiatry*, 37.

117 Greenway, “Nervous Disease,” 53.

118 Greenway, “Nervous Disease,” 60–66. Electrical medicine has been plagued by questions of efficacy since its advent in the mid-eighteenth century. To some degree, the history of electrical medicine can be viewed as a continuous struggle for credibility and acceptance. See Paola Bertucci and Giuliano Pancaldi, eds., *Electric Bodies: Episodes in the History of Medical Electricity* (Bologna: Università di Bologna, 2001). Electroconvulsive therapy, which was developed in 1938, has undergone various waves of rejection and acceptance (for a social history of electroshock in the United States see Kneeland and Warren, *Pushbutton Psychiatry*). More recently, a variety of electromagnetic stimulation techniques (i.e., deep brain stimulation, vagal nerve stimulation, transcranial magnetic stimulation, neuromuscular stimulation, etc) have been approved by the FDA to treat a variety of disorders. See Food and Drug Administration, “Neurostimulation Devices (21 C.F.R. 882),” accessed November 20, 2016, <https://www.accessdata.fda.gov/scripts/cdrh/cfdocs/cfcfr/CFRSearch.cfm?CFRPart=882>

While it is unclear whether the use of the medical battery by consumers contributed to the decline of the electrotherapeutics, the fact that both “quack” electrotherapy products and consumer medical batteries continued to be sold (and used) by the public well into the 1910s certainly did not help the professional reputation of the field. Indeed, as late as October 1917, the *Electrical Record* recommended that its readers purchase a consumer medical battery as a “holiday gift.”¹¹⁹ Gradually, however, the consumer medical battery waned in popularity, and was replaced by new versions of home electrotherapy products, such as vibrating machines,¹²⁰ high-frequency devices like the Violet Ray,¹²¹ and so-called oxygen delivery systems like the Electropoise.¹²²

One major factor in the decline of the consumer medical batteries—which were often marketed with cure-all claims—was the AMA’s anti-quackery campaign and related actions taken by regulatory authorities against companies that made unsubstantiated claims for their products. Though the crackdown on “quack” food and drugs had begun in earnest after the passage of the 1906 Pure Food and Drug Act, the law provided for the regulation of only food and drugs, not devices. To combat the “nostrums” that were still on the market, the AMA created a Propaganda Department (later renamed the Bureau of Investigation) in 1913 to investigate fraudulent medical products.¹²³ The Department worked closely with regulators such as the Department of Agriculture’s Bureau of Chemistry (which enforced food and drug law prior to the establishment of the Food and Drug Administration); the Post Office Department, which had the authority to take action for fraudulent schemes run through the mail, and the Federal Trade Commission (FTC), which took action for “unfair trade practices.”¹²⁴ For example, in 1920 the FTC filed a complaint against the Electric Appliance Company of Burlington, Kansas, for circulating “false and misleading” advertisements about its electric belts, electric insoles, and medical batteries.¹²⁵ However, it was not until 1938 that the government acquired power to regulate medical devices, when the passage of the Federal Food Drug and Cosmetic Act gave the FDA authority to regulate products that made therapeutic claims.¹²⁶

119 “Electrical Holiday Goods: Suggestions for the Selection of Appropriate Gifts, *Electrical Record and Buyer’s Reference* 22 (October 1917), 82.

120 Shelton Vibrator; “Health and Beauty,” Shelton Electric Co, ca. 1910; and Wappler vibrators in *Wappler: Cautery and Light Apparatus and Accessories* (New York: Wappler Electric Mfg Co, 1914), 42-45. BLC.

121 de la Peña, *Body Electric*, 121-126.

122 Ibid.

123 Eric W. Boyle, *Quack Medicine: A History of Combating Health Fraud in Twentieth-Century America* (Santa Barbara, CA: Praeger, 2013), 62.

124 Ibid., 74-77.

125 Federal Trade Commission v. The Electric Appliance Co., of Burlington, Kansas. Docket 340. March 19, 1920. Federal Trade Commission Decisions 2 (1920) 335-340. Evidently, however, the company remained in business for another decade and a half: in 1937 the FTC again ordered the company to “cease and desist” making “unfair representations.” FTC Order for Press Release, November 27, 1937. AMA Health Fraud Archives, Box 0230-04.

126 See Peter Barton Hutt, Richard Merrill, and Lewis Grossman, *Food and Drug Law: Cases and Materials*, 4th ed. (St. Paul, MN: West Academic, 2014), 10-11.

CONCLUSION

The medical battery was used to provide electrical treatments in the home and clinic for nearly five decades (1870–1920). Though companies marketed medical batteries primarily to either consumers or physicians, this paper has demonstrated that the lines between what was considered a consumer product and a medical device were often muddled. Some physician-oriented companies marketed their products directly to consumers; conversely, consumer-oriented companies advertised their products to physicians.

Most striking, however, was the existence of the “family battery,” a product that was sold by every major electromedical instrument manufacturer, yet aimed at non-physicians for the purposes of self-administering electrical stimulation. Although mentions of patients self-administering electricity are almost entirely absent from medical textbooks and journals, existing evidence—both from the long life of the family battery as well as from criticism that emerged from a handful of physicians—suggests that physicians were indeed recommending that their patients self-administer electricity at home, whether via the family or consumer battery. The handful of physicians who publicly advocated against the home use of the medical battery felt that its use by the laity threatened the image of electrotherapy as a skilled medical procedure. Yet despite their objections, the medical battery remained in the hands of consumers well into the 1910s. The decline of the medical battery can be attributed to a constellation of factors, including shifting interest towards newer technologies, the disappearance of electrotherapeutics as a whole, changing conceptions of nervous disease, and the institution of regulations governing medical devices and advertising claims.

Interestingly, modern books and articles related to the history of electrical medicine rarely mention the use of galvanic or faradic electrotherapy in America in the late nineteenth and early twentieth century, and the little scholarship that exists on the topic is found mostly in cultural and social histories. While there are likely a number of reasons for this—one being that American physicians did not conduct studies of electrophysiology as did their European counterparts¹²⁷—it is also possible that the anti-quackery campaigns of the 1920s retrospectively cast a pall over the legacy of late nineteenth- and early twentieth-century electrotherapeutics.

Indeed, electrotherapeutics of this period seems to be remembered more for quackery than for the work conducted by regular physicians. Furthermore, in antique markets today, medical batteries—which are currently traded and sold on places like eBay.com—are colloquially referred to as “quack devices” or “quack machines.”¹²⁸ That the product has become synonymous with quackery in the world of collectors is an ironic final coda, because as I have shown throughout this paper, the medical battery was the one consumer electrotherapy product *not* considered as such by medical professionals who practiced electrotherapy. Indeed, the medical battery occupied a unique position, flourishing for nearly five decades both in the domain of medical practitioners

127 Rosner, “The Professional Context of Electrotherapeutics,” 79.

128 At any given time, there are hundreds of medical batteries for sale on the online auction site eBay.com, ranging in price from \$50–300, depending on condition. There are so many surviving medical batteries that a second market has arisen just in their sale and trade, and a nearly 500-page book, *Currier's Guide to Electrotherapy Instruments*, serves as a detailed guide for medical battery collectors.

and that of home consumers, blurring the boundaries between medicine and consumerism.

ACKNOWLEDGEMENTS

I would like to thank Susan Silbey, Jonathan Reisman, and the two anonymous reviewers of this manuscript for their insightful comments, and to the staff at the Bakken—particularly Rachel Howell, Adrian Fischer, and Juliet Burba—for invaluable research assistance.

This chapter is devoted to ads from the late 1800's to the early 1900's that are related to the topics discussed in Volume II. Some are self-explanatory, while others require captions. A similar section, in Volume I deals with battery ads, generally.



The New Medical Battery.
The Earth-Magneto. THE BEST OF ALL ELECTRICAL DISCOVERIES.
 INDORSED BY PHYSICIANS, ELECTRICIANS AND SCIENTISTS.

The Earth-Magneto combines the most essential forms of electricity known in Electro-Therapeutics, viz.:

THE STATIC-MAGNETIC-GALVANIC.
 Can be used by the most nervous or sensitive man, woman, or child.
IT GIVES NO SHOCK OR SENSATION.

The Earth-Magneto will permanently cure all forms of Nervous Diseases, Gout, Dyspepsia, Constipation, Rheumatism, Neuralgia, Sciatica, Insomnia or Sleeplessness, Melancholia, Paralysis, Lumbago, Pain in the Back or Limbs, and Kidney, Bladder or Liver Complaints, Headaches, Nervousness, Female Complaints, Wasting Diseases, etc., etc.

The Earth-Magneto Medical Battery Co.,
 19 Union Square, West, New York.

Page from Sears Catalog showing telegraph unit, etc.

THE MYSTIC.
 A PORTABLE PARADIC BATTERY.
GENUINE ELECTRICITY.
NO HUMBUC!

Full directions accompany each battery. Can be carried about without spilling battery fluid.
 Size of Machine, in fine wood box, 4½ x 4½ x 5½ high.
 All metal parts nickel-plated.
 Will be delivered free to any part of the U. S. for \$3.50, by

F. G. OTTO & SONS,
 345 Fourth Avenue, New York.
 SURGICAL INSTRUMENTS, ELASTIC STOCKINGS, &c., &c.

TRY THEM.

Pat. Aug. 11, 1885. F. G. Otto & Sons, Sole Agents.

418 BEARS, ROEBUCK & CO., Chicago's Supply House on Earth, Chicago. CATALOGUE No. 16.

OUR

\$18.00 Giant Power Heidelberg Electric Belt

FOR RHEUMATISM, NEURALGIA, SCIATICA, BRUISES, SCALDS, BURNS, AND ALL AFFECTIONS OF THE NERVOUS SYSTEM.

SEND FOR OUR LATEST CATALOGUE FREE OF CHARGE.

OUR SHIRT POWER

ASK THE DOCTOR!

OUR SHIRT POWER OR GARDNER HEIDELBERG ELECTRIC BELT AT \$18.00

DOESN'T STOPPED IN SILENCE.

ARE YOU IN DOUBT?

HOW THE GARDNER HEIDELBERG ELECTRIC BELT IS MADE.

THE BATTERY

ELECTRODES



EVERY BELT IS PUT OUT UNDER OUR OWN SUPERVISOR

CURRENT REGULATOR

THE GARDNER CURRENT

FOR RHEUMATISM

NO. 100000 - OUR SHIRT POWER CURRENT BELT - \$18.00

By Royal Letters Patent.

THE GREAT HEALTH RESTORER.

DR. LOWDER'S

PATENT **MAGNETO-ELECTRIC BATTERY** MEDICAL

STOP TAKING MEDICINE, AND TRY

Patent's Own Remedy - Electricity!





PRICE FIVE SHILLINGS EACH.

Rest complaints effectively cured by Dr. Lowder's Battery.

WILLIAM C. NEFF,

MANUFACTURER OF

ELECTRO-MAGNETIC MACHINES,

PHILADELPHIA.

These Machines are used by our best physicians in their practice, and by many families without the aid of a physician. They can be managed by following the directions accompanying the machine, being self-acting in their operation.

READ WHAT THE LADIES SAY:

Attention of Ladies is directed to the following SATISFACTORY CASES, which are worthy of the investigation by all who suffer from those DIS-ING IRREGULARITIES peculiar to the Sex:—

J. HAWKEY, 16, Matilda-street, Barnsbury, London, N., April 21, 1883:—"I have received great benefit since wearing ELECTROPATHIC BELT. Wearing it has improved my health. I fail to express in words the satisfaction it gives me. I felt so well for years as I have since wearing your Belt. I was under the care of a physician for six months, suffering from irregularities incidental to debility and bad circulation, despairing of ever feeling well again, when I was recommended your ELECTROPATHIC BELT. I cannot say enough in favour of it, but I shall be glad to communicate with any lady who would like further particulars of my case."

INTERNAL WEAKNESS.

L. HUDSON, Twyford, Derby, writes, March 20, 1883:—"Seven months ago I purchased one of your ELECTROPATHIC BELTS. I need not describe the benefits here, but refer you to my letter of June 17, 1882, No. 3144. I have worn the Belt every day since that time, and it has been an untold comfort to me. I would not have been able to get out one, and cannot say enough in favour of your Belt. I regret it is not better known. I shall be glad to write to any lady who may wish to hear more particulars respecting my case, and shall certainly send you appliances to my friends."

IMPORTANT TO INVALIDS.

Consulting Electrician and member of the Electrical Association, who has had the application of Electricity to the Cure of Disease as a special study, attends daily (personally or by letter) at the PRIVATE CONSULTATION ROOMS, 52, Oxford-street, London, W. A distinguished and experienced Lady is also in attendance.

Patients at a distance should send a Private Advice Form, etc.



READ WHAT

Dr. ANDREW WILSON
"I observe that the Belt has been frequently used with few genuine electrical safety and satisfaction at 52, Oxford-street, London, W. Director of the Com- quackery it is highly development of electri- cessfully projected."

enterj
Comp
the M
of per
of cap
factul
to he
do no
will t
its m
appli

Pleas
next

A Hundred-and-thirty-two Page Treatise, copiously illustrated, entitled

"ELECTROPATHY; or, HARNES'S GUIDE TO HEALTH," post-free.

Twinvicta

MAINS-BATTERY PORTABLE

£18.9.9 TAX PAID

MADE IN ENGLAND BY SYNTON BROS LTD
222, REGENT STREET, LONDON, W.1

WONDERFUL DISCOVERY!

The Crowning Medical and Scientific Triumph of the 19th Century!

"The Blood is the Life."

The Wonderful Magneto-Electric Apparatus!

Drive Away Death! Try Nature's Remedy!
Be Free of Disease!

As Lightning Purifies the Air, so must Electricity Purify the Blood!

R. V. WAGNER & CO., CHICAGO. 87

FRICITION SPARK TREATMENT.

This cut represents the most convenient way of applying the spark. The patient is seated upon an insulated platform and attached to the positive pole. The sliding electrodes are then separated. The operator uses a ball or roller electrode which is attached to a flexible cord or chain. If a small amount of current is desired, the flexible cord is held by an insulated hook a great distance from the floor or other ground so that all current which passes from the patient to the ball and into the cord must pass through a thick layer of air to reach the ground, the air acting as a rheostat. As it is desired to increase the strength of the spark the cord may be lowered, nearer and nearer the floor, until the full tolerance of the patient is reached. This treatment is principally used for its counter-irritant effect and for the stimulation of the skin and superficial blood vessels, especially valuable in the treatment of eczema and scurvy sores.

30 DAYS' TRIAL

DR. DYE'S
VOLTAIC BELT

(BEFORE — AND — AFTER)

Electric Appliances are sent on 30 Days' Trial.

TO MEN ONLY, YOUNG OR OLD,

WHO are suffering from NERVOUS DEBILITY, LOST VITALITY, LACK OF NERVE FORCE AND VIGOR, WASTING WEAKNESSES, and all those diseases of a PERSONAL NATURE resulting from ABUSES and OTHER CAUSES. Speedy relief and complete restoration of HEALTH, VIGOR and MANHOOD GUARANTEED. The grandest discovery of the Nineteenth Century. Send at once for Illustrated Pamphlet free. Address

VOLTAIC BELT CO., MARSHALL, MICH.

THE BELL SYSTEM ELECTRIC CO. MANUFACTURERS

WILLARD RADIO BATTERIES

THE BATTERY OF THE BELL SYSTEM

WTAM



"My wife was right"

3-Point Superiority

LOOK FOR THIS SIGN

PHILCO
PHILADELPHIA BATTERY

THE BATTERY MAN

Get Your Profits Ready-Made

WHITAKER BATTERY CABLES

THE BATTERY WITH 9 LIVES

Presto-Lite

BUILT TO STAND THE STRAIN OF MODERN BATTERY DEMAND

S.O.S. TRADE MARK REGISTERED

FARM LIGHT BATTERIES

NEW AND GREATER
S. O. S.
FARM LIGHT BATTERIES
YOU WANT A RELIABLE QUALITY PRODUCT!

Our new S. O. S. "P" type Farm Light Batteries include new white PORCELAIN COVERS—PLATES SUSPENDED FROM THE COVER—LARGE ACID SPACE—NO CHANCE FOR SHORT CIRCUITS FROM ACCUMULATIONS IN THE BOTTOM OF JAR.

S. O. S. Batteries proven best by years of service!
New Distributors' Contract on Auto, Radio and Farm Lighting Batteries ready!

— WRITE TODAY —
S. O. S. are the
ONE QUALITY BATTERIES
BEST — BAR NONE!

Victor Storage Battery Co.
Rock Island, Illinois
ESTABLISHED 1914

Portable Electro-Medical Batteries.

These magnetic instruments are of undoubted value as the instruments through whose agency physicians effected almost miraculous cures. Our most learned doctors and physicians acknowledge their efficiency in even the worst cases of paralysis, rheumatism, neuralgia, and in fact, all nervous diseases. These machines may be used by all invalids with perfect safety. When doctors fail to effect a cure with drugs and medicines, and electricity is resorted to in the last stage of disease, even then, under such immense disadvantages, electricity often cures.

1.35
ow-
ng).
han
han

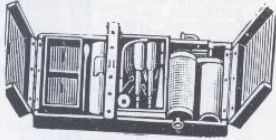

.40
4.25
.50
5.00
.60
6.00

24175 Gaiffe's Battery, three currents, with silk covered conducting cords, two insulated handles, one metallic brush, one olive shaped exciter, one spherical exciter and one vial of bisulphate of mercury. In polished mahogany case, 7 1/4 x 4 1/4 x 1 1/4 in. Complete, with full directions. Weight, 1 1/4 lbs. \$7.75
24176 Gaiffe's Battery, with same size coil as in preceding, producing two currents instead of three. Mounted in single cover mahogany case, 6 1/2 x 4 x 1 1/4 inches, containing two insulated handles and one vial bisulphate of mercury. Weight, 1 pound. Each.....\$6.25

.60
6.25
.75
7.50
.85
8.50

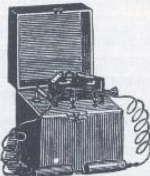

24177 The Crown Family Battery. The merits of this battery will be easily appreciated as possessing neatness of design and simplicity of operating. A pleasant and uniform electric current, both mild and powerful. Three different and distinct currents are produced—the primary, secondary, and both combined in intensity. Mounted in polished cherry case with nickel handles. Size, 6 3/4 x 5 1/4 inches, with full directions for using. Highly recommended. Weight, 2 1/4 lbs. Price, complete.....\$8.50

DS.
ustic
ly of
self-
screw
tele-
line 1/2
atest,
work-
phone
ones,
feet
s and
g the
order



24178 Alpha Faradic Family Medical Battery, constructed upon improved scientific principles and designed for private or professional use. Full description of apparatus, directions for operating and directions for making solution furnished with each instrument. Weight, 3 1/2 lbs. Each.....\$5.00

\$5.00
o. 18
ound
\$0.31

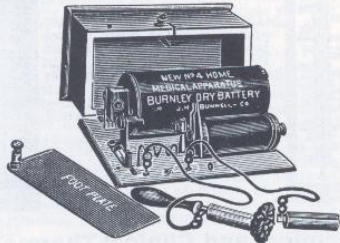

24179 The New Home Electro-Medical Apparatus, with dry battery. This battery is the most convenient and reliable of any hundreds of forms ever introduced. It is reliable, because with its dry battery so much less care is necessary to avoid getting it out of order than is required with any other known form. The entire absence of acids, liquors or salts will be appreciated by any one who has ever had occasion to use a medical battery. The appliance furnished with the apparatus consists of foot-plate, sponge, cords and handles (electrodes). The electrode having a wooden handle is used as a sponge-holder when required. The size of the apparatus is 3 1/4 x 5 x 8 1/4 inches. Price, complete,....\$7.00 Extra battery, per cell \$0.75 Extra Sponge Holder 50 Extra Handles, pair..... .75 Extra Metallic Hair Brush, electrode..... 1.25 Extra Cords, 4 feet, per pair..... .50

18.00
35.00
24218.



24180 The Genuine Smith & Shaw Portable Pocket Battery. Powerful current. The most practicable and thorough pocket battery made. Cells cannot spill contents. Price, with two cells (weight, 1 1/4 lb.).....\$8.50 Price, with three cells (weight, 2 lbs.).....\$10.00

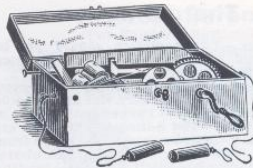

Magnetic Electro Battery.

24182 Davis & Kidder's Genuine Magneto-Electric Machines. Price, each, \$7.25 Weight, 6 3/4 lbs.

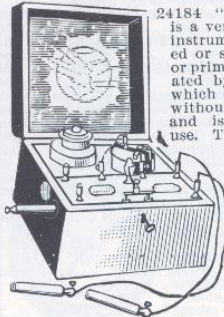

24184 "Family" Battery. This is a very effective and portable instrument, produces the induced or secondary, and the direct or primary current, and is operated by an open battery which can be used for months without changing the solution and is constantly ready for use. The power may be increased by gradually withdrawing the tube from the helix. In polished black walnut case with cords and handles; weight, 8 lbs. Each.....\$10.00

Medical Battery Parts.

Order No. 24185 and be sure to specify what battery the parts are for. Each.

Zincs for the Crown Family Battery.....	\$0.20
Carbons for same.....	.25
Glass Jars for same.....	.25
Tops complete for same, zinc and carbon attached.....	.65
Zincs for the Alpha Battery.....	.25
Carbons for same.....	.25
Glass Jars for same.....	.25
Zinc for Family Battery. Per pair.....	.50
Postage on pair zincs.....	.18
Platinas for same.....	1.00
Clamps for same.....	.25
Cords for same. Per pair.....	.50
Glass Jars for same.....	.25
Metal Springs for Magnetic Battery.....	.10
Cord belt for same.....	.05
Bisulphate Mercury for use with batteries Nos. 24175, 24176 and 24180 per ounce.....	.10
Price, per 1/4 lb. bottle.....	.75
Price, per 1 lb. bottle.....	1.25
Bichromate Potassium for use with batteries, Nos. 24177 and 24178. Per lb.....	.35

Medical Induction Coil, Without Battery.

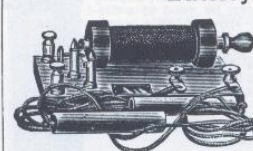

24186 Induction Coil, mounted on neat wooden stand with pair of hand electrodes and sponge holder of best quality. Can be operated with any acid battery. Price, without battery.....\$3.50

24187 Same as above, complete with dry battery cell, ready for use. Weight, 3 1/2 pounds. 4.00

Electric Motors.



The Porter Electric Motor, a practical machine for a little money. An entirely novel principle underlies the construction both electrically and mechanically, insuring simplicity, low cost, reduced size, diminished weight, higher speed and wonderful economy in power required to operate them.

24190 The No. 1 Motor, although a very small one in size, is highly efficient. With one

cell of acid battery it will operate a small dental lathe, a fan, a revolving window stand, an egg beater, a music-box, etc. It is no toy. Its electrical efficiency is about 1/2 horse power, or from 35 to 40 watts on a continuous run. No better motor can be furnished to meet the wishes of young students engaged in the study of experimental physics. Its efficiency will surprise the user. Weight, 1 1/4 pounds. Price, each.....\$2.00
24191 The No. 2 Motor, same construction as above, but larger size, weighing 3 pounds and capacity of 1/2 horse power. Price..... 4.75

WE CARRY IN STOCK a full line of DRUGS, CHEMICALS, PHARMACEUTICAL PREPARATIONS, Etc., Etc., and can fill orders promptly and correctly. An experienced druggist is in charge, and he will compound prescriptions when so ordered. Send for our Drug List. Mailed free.

THE MEDICAL JOURNAL

Vitogen
Is the Most Reliable Antiseptic Dressing Powder
 THE G. F. ARNEY CO.

THE PEERLESS AUTOMATIC ELECTRIC BATTERY
 THE IDEAL BATTERY FOR PROFESSIONALS

PEERLESS BATTERY COMPANY, 231 FIFTH AVENUE, CHICAGO

The New Medical Battery.
The Earth-Magneto. THE BEST OF ALL ELECTRICAL DISCOVERIES.
 INDORSED BY PHYSICIANS, ELECTRICIANS AND SCIENTISTS.



The Earth-Magneto combines the most essential forms of electricity known in Electro-Therapeutics, viz.:

THE STATIC-MAGNETIC-GALVANIC.
 Can be used by the most nervous or sensitive man, woman, or child. **IT GIVES NO SHOCK OR SENSATION.**

The Earth-Magneto will permanently cure all forms of Nervous Diseases, Gout, Dyspepsia, Constipation, Rheumatism, Neuralgia, Sciatica, Ischemia or Sleeplessness, Melancholia, Paralysis, Lumbago, Pain in the Back or Limbs, and Kidney, Bladder or Liver Complaints, Headaches, Nervousness, Female Complaints, Wasting Diseases, etc., etc.

The Earth-Magneto Medical Battery Co.,
 19 Union Square, West, New York.

THE LAW BATTERY



PATENTED.
THE BEST OPEN CIRCUIT BATTERY
 in every respect, without any equal. **SUPPLANTING ALL OTHERS!**
 With its introduction, Battery Trouble and Battery Expense become things of the past. As a **TELEPHONE BATTERY,** the L.V. unquestionably excels all others. Now almost universally used by the Telephone Exchanges of the whole country. The materials used in its construction are the very best. No noise, no odor. Great recuperative power. Nothing to remove except the zinc and cad anodes; no poisoning, gassing or prisms. Fits the standard size battery-tray. Send for Circular and Schedule of Prices. Single Cells, \$1.25. Manufactured and for sale by the **LAW TELEGRAPH COMPANY**
 140 Fulton Street, New York.
 W. L. GARDNER, CHICAGO, Mgr. FRANK BEAN, Registrar.

A NEW Star is Born!

GENERAL ELECTRIC'S NEWEST GOLDEN TONE RADIO (MODEL J-105)



The Advertising Archives

Golden Tone RADIO

HEAR the radio that makes music really live! Visit your dealer and ask for a demonstration of the beautiful, new G-E Golden Tone Radio, model J-105. Hearing is be-



A uniform, constant power supply for both "A" and "B" circuits

Here at last is a satisfactory and enduring power supply for your radio set. Balkite Radio Power Units furnish constant voltage to both circuits, and will give you radio-arc-free, clean, precise and steady. The Balkite Battery Charger keeps your "A" storage battery charged. Balkite "B" maintains "B" filament-cathode and variable plate current from the light socket.

Based on the same principle, both the Balkite Battery Charger and Balkite "B" are entirely portable. They have no bulbs or transformers, and nothing to break, adjust, or get out of order. They have a very low voltage consumption, are simple and efficient in operation, and can be put in use at any time for recharging or in light sockets. Back one governmental safety certification.

Sold by leading radio dealers everywhere.

BALHITE Radio Power Units

REGISTERED PATENTED TRADE MARK

Manufactured by **EMERSON ELECTRIC COMPANY, Inc.** - East Chicago, Illinois

32 BIBLIOGRAPHY

1. Apocalypse Delayed – The Story of Jehovah’s Witnesses (University of Toronto Press, 1985)\
2. Automatic Block Signaling: https://en.wikipedia.org/w/index.php?title=Automatic_block_signaling&oldid=1121765313
3. Balkite Ad – The Music Trade Review, September 3, 1927.
4. Balkite Ad. – Radio Retailing, November, 1926.
5. Balkite Battery Charger – The Wireless Engineer, April, 1925
6. Basic Railway Signaling: www.railway-technical.com/signals/infopapers-6-basic-railway.pdf
7. Battery Operated Radios of the 1920’s & ‘30s:
<https://www.radioguy.com/info0/about%20battery%20radios.htm>
8. Batteries and Early Railway Telegraph Lines: <https://membersKos.net/sdagnon/te4.html>.
9. Batteries Not Included: FOHBC Bottles and Extras, November – December 2010.
10. Batteries & Early Telegraph Lines: members.kos.net/sdagnon/te4.html
11. Batteries: Types and History: <http://edison-techcenter.org/batteries.html>
12. The Battery Invented 120 Years Before Its Time: www.BBC.com/future/article/20210223-the-battery-invented-120-years-too-soon
13. Benjamin Franklin and Electricity: <https://www.revolutionary-war-and-beyond.com/benjamin-franklin-and-electricity.html>
14. Benjamin Franklin’s Pioneering Electrical Work Influenced Today’s Technology: <https://American-history.si.edu/press/releases/Benjamin-Franklin-electrical-influence>
15. Birth of Electrochemistry: <https://electrochem.org/birth-of-electrochemistry>
16. Brief History of Electricity: first 100 years history timeline: <https://powertrical.com/history-of-electricity>
17. Brief history of Electricity: www.ecmag.com/section/year-business/brief-history-electricity
18. Brunel, J.H. and company from a presentation by Dr. Joseph Jacobs at the 1994 Antique Wireless Association Conference: www.jhbunel.com/bunelcohistory.html
19. Bunnel versus Bunnel: www.telegraph-history.org/j-h-bunnel/index.html
20. Bunnel Telegraphic and Electrical Company: www.telegraph-history.org/Brunel-tel-tel-eect-catalog
21. Bunnel, History of J.H. and Company: [www.jhbunel.com/bunel Co. history.html](http://www.jhbunel.com/bunel%20Co.%20history.html)
22. Brunel Telegraph Apparatus, 1918: www.dieterbrackman.de/Morsetasten/memo-pages/M_catalog.htm
23. Civil War Artifact Across the Decades: Davis & Kidder’s Patent Magneto-Electric Machine: Surgeon’s Call, Volume 22 No. 2, 2017
24. Davis and Kidder: guide to electrotherapy instruments and history of their American makers: excerpts: [www.electrotherapymuseum.com/2010davis Kidder/index.htm](http://www.electrotherapymuseum.com/2010davis%20Kidder/index.htm)
25. Davis and Kidder’s patent magneto-electric machine for nervous diseases: https://american-history.si.edu/collections/search/object/nmask_727990
26. Davison Kidder: improved magneto-electric machine electro-medical-guide and directions for the use of the Smith and Shaw closed cell pocket batteries personal copy
27. The Delco Light Plant: <https://www.farmcollector.com/community/farm-shows/delco-light-plant-zmlz13janzbea>

28. Difference Between faradic and galvanic current: <https://physics.unit.com/difference-between-faradic-and-galvanic-current/>
29. Edgar Casey: <https://en.wikipedia.org/wiki/Edgar-Casey>
30. Edison companies: <https://edison.rutgers.edu/life-of-edison/companies>
31. Thomas Edison: www.britannica.com/biography/thomas-edison
32. Thomas Edison: en.wikipedia.org/wiki/Thomas_Edison
33. electrochemistry: primary and secondary batteries: www.2.chem.wisc.edu/deptfiles/genchem/netorial/rottosen/tutorial/modules/electrochemistry/o6battery/18_61.htm
34. The Electric Purple Snake-Oil Machine > The Violet ray machine's Tesla coil could cure almost anything – supposedly by Allison Marsh: <https://spectrum.ieee.org/violetray>
35. Electricity in Medicine: <https://digeriepo.nlm.nih.gov/ext/dw/10173498/PDF/101734948.pdf>
36. Fansteel: <https://www.company-histories.com/Fansteel-Inc.-Company-History.html>
37. Farm Lighting Batteries-Section III: [https://powerstream.com/1922/battery-1922_WITTE/battery_files/chapter 17.htm](https://powerstream.com/1922/battery-1922_WITTE/battery_files/chapter%2017.htm)
38. Farm Radios: <https://www.farmcollector.com/equipment/farm-radios/>
39. F.G. Otto & Sons: <https://www.getnj.com/jcpast/messages/106.shtml>
40. Fire Engineering Company:
41. fire alarm call box: [https://en.wikipedia.org/w/index.php?title= fire_alarm_call_box&oldid=1053472235](https://en.wikipedia.org/w/index.php?title=fire_alarm_call_box&oldid=1053472235)
42. Fulmen Battery Company: https://en.wikipedia.org/wiki/Fulmen_Batteries
43. Ford, Edison and the EV That Almost Was; Gear, June 18, 2018
44. Patent: Funnel for Filling Storage Battery Cans, Analogous Purposes, T.A. Edison, March 3, 1903 721, 870
45. History of Battery Technology: <https://Liossmart.com/en/history-of-battery-technology/>
46. History of the Battery: https://chemeurope.com/en/encyclopedia/history_of_the_battery.htm
47. I history of the battery: HT TPS://EN. Wikipedia.org/wiki/history-of-the-battery
48. History and Development of the Battery: <https://Britannica.com/technology/battery-electronics/development-of-the-battery>
49. History of Electricity: <https://electricityforum.com/history-of-electricity>
50. History of Electricity: hcsud2.org/vimages/shared/vnews/stories/5863e7aa1C11e/history%20of%20of%20electricity.pdf
51. History of Electricity: [HTTPS://electricalcuriosity.com/history-of-electricity/](https://electricalcuriosity.com/history-of-electricity/)
52. History of Electricity: <https://thehistoricalarchive.com/happenings/57/the-history-of-electricity-a-timeline/>
53. History of the Battery: https://en.wikipedia.org/w/index.php?title=History_of_the_battery&oldid=1147113383
54. History & Evolution of Signal Systems: [//railroads.fra.data.gov/elibrary/stc-o-history-and-evolution-railroad-signaling](http://railroads.fra.data.gov/elibrary/stc-o-history-and-evolution-railroad-signaling)
55. History of Electricity: <https://info.elumisfoundation.org/history-of-electricity/>
56. History of Rail Transportation in the United States: https://en.wikipedia.org/w/index.php?title=History_of_rail_transportation_in_the_United_States&oldid=1166954562
57. History and Timeline of the Battery: <https://thoughts.com/battery-timeline-1991340phys.org/news/2015-04-history-batteries.html>
58. History, Theory & Construction of the Electric Telegraph: <http://w1tp.com/partel.htm>
59. how batteries work: <https://electronics.howstuffworks.com/everyday-tech/battery3.htm>

60. how batteries work <https://electronics.HowstuffWorks.com/everyday-tech/battery2.htm>
61. how batteries work: <https://electronics.Howstuffworks.com/everyday-tech/battery1.htm>
62. how Edison, Tesla and Westinghouse battled to electrify America:Elizabeth Nics. Updated: October 24, 2019, original: January 30, 2015
63. J.H. Bunnell & Co.: jh.bunnell.com/bunnellco.history/shams
64. James W. Queen & CO.
[https://en.wikipedia.org/w/index.php?title=James W. Queen %26 Company&oldid=1146509850](https://en.wikipedia.org/w/index.php?title=James_W._Queen_%26_Company&oldid=1146509850)
65. James W. Queen & Co. Scientific American, April 28, 1888
66. Jehovah's Witnesses and Healing: Dr. George Chrysis's, University of Birmingham, UK paper presented at the CESNUR 2014 International Conference Baylor University, Waco Texas
67. McIntosh Electrical Corp:
https://www.radiomuseum.org/dsp_hersteller_detail.cfm?company_id=13584
68. the medical battery in the US (1870-1920): <https://academia.org/jhmas/article/22/21/663073507>
69. the medical battery in the US (1870-1920): Anna Wexler: Journal of the history of medicine and allied sciences volume 0 numbers zero pages 1-27
70. The Medical Battery in the U.S. (1870-1920): JHMAS, volume 72, issue two, April 2017 pages 166 to 192: [HTTPS://doi.org/10.1093/jhmas/jrx001](https://doi.org/10.1093/jhmas/jrx001)
71. Medical use of electricity by George M Beard MD and ADD Rothwell MD (originally published 1867 by William Wood and company, reprint published by LeGare Street Press.
72. Monsieur Callaud: mysterious Frenchmen: <https://upsbatterycenter.com/blog/monsieur-callaud>
73. practical chapters on static electricity: SH Mundell, MD published by galvanic-forensic manufacturing company. (Van Houghton and 10 broke, proprietors)
74. pre-industrial history of electricity: <https://expresselectricalservices.com/a-brief-history-of-electricity>.
75. Powering Your Antique Battery Radio:
<https://antiqueradio.org/bsupply.htm?ref=driverlayer.com>
76. www.PowerStream.com/1922/battery
77. Prest-O-Lite Story: Union Carbide Corp., Linde Division.:
www.firstsuperspeedway.com/sites/default/files/Prest-O-Lite.pdf
78. Primary cell: www.britannica.com
79. quack medicine: <https://www.ajwrb.org.quackmedicine>
80. glass lens colors: www.railroadiana.org/globe/pgRRglasscolors
81. Rail Crossing Warning Signals:
https://en.wikipedia.org/w/index.php?title=Automatic_block_signaling&oldid=11231765313
82. Railroad Development: CPRR.org/museum/RR_development_html
83. Railway signaling: <https://econstructioncareers.com/news-insight/how-trains-change-track>.
84. Railway signaling: <https://econstructioncareers.com/news-insight/rail-signaling>
85. railway signaling: www.chartertoconductor.com/railroad signals
86. railway signaling: <https://railroadsignals.us>
87. Railway Signaling:
https://en.wikipedia.org/w/index.php?title+Railway_Sigbaling&oldid=1167761703
88. Railway Signaling Since Birth to ERTMS: railwaysignalling.eu/wp-content/upload/2013/1/railway_signalling_since_birth_to_ERTMS.pdf

89. railway storage battery car company: https://midcontinent.org/rolling_stock/builders/railways_torbat.htm
90. [Toulouse, Julian Harrison: 1971, Bottle Makers and Their Marks, Thomas Nelson, New York](#)
91. [Tap, Tap Tap of the Telegraph: theantiquesalmanac.com/thetaptaptapofthe_telegraph.htm](#)
92. Tillotson, LG: LG Tillotson and Company (telegraph-history.org)
93. Types of batteries: <https://byjus.com/chemistry/battery-type/>
94. Tudor Batteries:
https://en.wikipedia.org/w/index.php?title=Tudor_batteries&oldid=1135755039
95. Henri Tudor: https://en.wikipedia.org/w/index.php?title=Henri_Tudor&oldid=1137546750
96. Voltamp trains:
www.tcaWestern.org/voltamp.htm#:~:text=voltamp%20was%20and%20early%20American%20manufacturer%20of%20Baltimore%20stive%20dealer%20in%20the%201890%20s
97. Thomas Edison's Accomplishments Go Beyond the Bulb to R&D:
<https://redshift.autodesk.com/articles/thomas-edison/accomplishments>
98. [Thomas Edison Companies: https://edison.rutger.edu/life-of-edison/companies](#)
99. [Train Wrecks, by Robert C. Reed: 1988, by Bonanza Press. \(Pictorial History of Accidents on the Main Line.](#)
100. Uranium Glass:
https://wikipedia.org/w/index.php?title=uranium_glass&oldid=1149263826
101. Uranium Glass: https://en.wikipedia.org/wiki/Uranium_glass.
102. The Violet Ray: From Quackery To Sex And Back Again:
<https://archire.randi.org/site/index.php/swift-blog/1209-the-violet-ray-from-quackery-to-sex-and-and-back-again.html>
103. What is the difference between Faradic and Galvanic Current:
www.Knowledgewow.com/what-is-the-difference-between-faradic-and-galvanic-current/
104. William Robinson and the track circuit: American Railway Association Signal Section>
The invention of the Track Circuit: The History of Dr. William Robinson's Invention of the Track Circuit. New York, N.Y.,USA: 1922
105. William Robinson (Inventor):
https://en.wikipedia.org/w/index.php?title=Automatic_Block_signaling&oldid=1121765313
106. Wincharger: <https://www.farmcollector.com/equipment/charged-by-the-wind/>

33 INDEX

- . Gaiffe, 128
- “Battery Insulators, Oil Insulators and Chloride Accumulators, 46,196
- A.R.A, 131, 133
- A.R.S, 131, 133
- Acme electro shock machine, 72
- Alexander Graham Bell,, 11
- Allesandro Volta, 10
- Alternating Current, 10,11,18,19
- anode, 16,18,19,21
- Associated Equipment, 184
- Australian, 35
- automatic water fill, 184-186
- available electric cars, 213
- Batteries, 15, 16, 20
- Batteries & Extras, 202
- battery, 9,20,23,24,25,26,28,121
- Battery Insulators, Oil Insulators, and Chloride Accumulators, 196
- Battery jars, 16
- battery oil, 6,31
- Battery rests, 15
- Battery Trays, 17,50
- Beard and Rockwell, 67
- Benjamin Franklin, 9
- Bibliography, 346
- Bisulfate of Mercury, 123
- block system, 131,134
- Bridge Rests, 187
- BSCO, 12
- Camille Faure, 10
- Campbell Bros, 191
- cathode, 16,18,21
- cell, 20,30
- Cell Cover, 29
- Charge Control Unit, 188,189
- Charles Chardin, 125-127
- Charles E. Hires Co, 193
- Chloride of Silver Battery Co., 93-94
- City of Light, 11
- Closed Block, 134
- Corrosion, 30
- crown cap, 41
- crown closure, 39-42,44
- Current Wars, 13,19
- Davis & Kidder, 84
- Direct Current, 11,13,18,19
- Drescher, 124
- dry cell, 94
- E.S.B. Co. No. 5, 52
- E.S.B. Co. No. 6, 53
- E.S.B. Co. No. 7-5, 52
- E.S.B. Co. No. 9, 54
- E.S.B. Co. No. 7, 53
- E.S.B.Co. No. 7.1, 53
- Edge Protectors, 30
- Edison, 9,11,12,13,19,31,56,97-101
- Edison Medical Batteries, 97-101
- Edison Storage Battery Co., 12-13
- electric current, 11,14,18
- Electric Storage Battery, 159
- Electric Storage Battery Company, 55
- Electric Vehicles, 57-60
- electricity, 13,29
- Electrodes, 21,22
- electrolyte, 15,20,27
- Electronic Radio Biola, 72-73
- electrons, 14-15
- ESB, 223-252
- Evaporation, 30
- Eveready, 29
- F.G. Otto & Sons, 77-79
- Family Batteries, 68-71
- Farm Batteries, 28,61,66
- flask style, 36-38
- Flemming, 68,95-97
- Floating Battery Post Bushing, 30
- Florence, 77
- G.N.CLAPP & Co, 114
- Galvano Faradic, 67,102-106
- Gamewell, 48,206-212
- Garrett & Osborn, 128
- Gassing, 30
- Gaston Plante, 10
- General Electric, 13,55
- Georg von Kleist, 9
- George Ohm, 10
- George Westinghouse, 11,12
- Granville T. Woods, 166
- Guide for North American Pin Type Insulators, 17
- Henri Tudor, 11
- Henry Ford, 12,57-60

Hydro Purok, 193
Irons, Charles & Sandi, 196,202
J.C. Morgan, 19
J.H. BUNNELL, 148-151
James W. Queen & Co., 85

LaLande, 12,97,266

Lead-Acid, 20

Leclanche, 20
Leyden, 9
Luis Drescher, 81-83
McIntosh, 68,91-93
Medical Batteries, 87
Mercury Bi-Sulphate, 123
Michael Faraday, 10
Mills electric shock machine, 72
Montgomery Ward, 70
mossing, 30
mud, 30
MURRAY-BAUMGARTEN, 115
MYSTIC, 78,79
National Carbon Company, 49,140
Nickel-Iron, 57
Nikola Tesla, 11
Open Circuit?, 134
Osgood's, 113-114
Otto Fleming, 95-97,124
Otto Flemming, 89
Parallel connections, 24
Patents, 195
Pieter van Musschenbroek, 9
Plante, 10,16,20
Plate Protectors, 30
plate spacers,, 184
plates, 21, 30
pocket Batteries, 122
Post, 36
Primary, 20
R.S.A, 133
Radios, 167-179
Railroad Signaling, 129-136
Samuel Morse, 10
sand trays, 17,50-56
Sears Robuck, 69,71

Secondary, 20
Sediment, 30
Series connections, 24
Smith & Shaw, 122
sounder , 145
Specialty, 78-79
specialty batteries, 28
Stammers 68
Street Car Power Plants, 253-265
Street Cars, 158-165
Team Edison, 58
Telegraph, 142-151
telegraph key, 144
TELEPHONE, 151-157
Telephone Exchanges, 152
Terminal, 30
The Black Edison, 166
THE DOW, 114
THE ELECTRIC STORAGE BATTERY CO, 184
The General Electric, 19

The Stair-Step, 61
third rail, 162-163
Thomas A. Edison, 9,10,11
Thomas-Huston, 55
Trolley Pole, 160
Two Tier, 61-62
Type A, 167
Type B, 167
Union Switch and Signal, 131
Uranium, 52-56
Van Houten and Ten Broeck, 102
Vaseline, 52-56
Vent Caps, 30
Vintage Advertisements, 338-345
Voltamp, 86-91
Waite & Bartlett, 68
War of the Currents, 19
WATERBURY, 41
Westinghouse, 11,13,19
Wexler, 67
Whitall Tatum, 28,77-81,91
Willard, 80,171
William Churchill, 132
William Robinson, 134
Zenith Wincharger, 167